

Modular condensing boilers

27020503 rev. 02 - EN - 03/2024



Condexa HPR

Modular condensing Wall-hung gas boilers

In conformity with Directive 2009/125/EC
Condensing thermal modules for indoor use
Possible cascade up to 280 kW
Modular design to ensure an easy and fast installation
Low polluting emissions, Class 6 (UNI EN 15502-1)

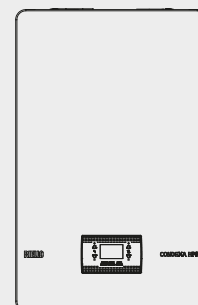

A Carrier Company

RIELLO
Energy For Life

MODULAR CONDENSING BOILERS

Indoor wall-hung gas condensing modules

Contents

<u>STAND-ALONE CONFIGURATION</u>	
Description and technical data	4
Dimensions and structure	9
Installation	12
<u>CASCADE CONFIGURATION</u>	
Description and dimensions	19
Installation	30
Description for specifications	33

MODULAR CONDENSING BOILERS

Indoor wall-hung gas condensing modules

CONDEXA HPR (stand-alone)

CONDEXA HPR is the modular wall-hung condensing system whose strength lies in its compact dimensions. The primary heat exchanger in stainless steel, with its horizontal form and front access to the combustion chamber, guarantees top performance in terms of efficiency and reliability over the years.

The range consists of 4 heating-only models, with thermal modules from 34,9 to 70 kW.

CONDEXA HPR can be installed on its own either indoors or in a partially protected place, but there is also the possibility to install up to 4 modules indoors in cascade format, with either an in-line or back-to-back configuration.

For the battery layout there is a new external system controller: simple and user-friendly, it can manage, parameterise and visualise up to 4 cascade modules and also manage up to 6 additional independent zones.

- Designed to function with mixtures of natural gas and hydrogen, up to a maximum of 20%
- Modulation ratio 1:8 with single installation, or up to 1:32 with battery installation
- Modulating circulator with high discharge head and low consumption levels
- Maximum operating pressure 5 bar
- Easy installation
- Wide range of accessories to complete both single and battery installation, whether with linear or back-to-back configuration

TECHNICAL DATA

DESCRIPTION	U.M.	CONDEXA HPR 35		CONDEXA HPR 45		CONDEXA HPR 55		CONDEXA HPR 70	
		G20	G31	G20	G31	G20	G31	G20	G31
Type of gas		G20 G31		G20 G31		G20 G31		G20 G31	
Gas category		II2H3P		II2H3P		II2H3P		II2H3P	
Country of destination		IT		IT		IT		IT	
Type of flue gas discharge installation		B23P; B53P; C13, C13x; C33, C33x; C43, C43x; C53, C53x; C63, C63x; C83, C83x; C93, C93x							
HEATING									
Nominal heat input (Hi)	kW	34,90		45,00		55,00		70,00	
Nominal heating capacity (80÷60°C)	kW	34,00		43,88		53,60		68,22	
Nominal heating capacity (50÷30°C)	kW	37,31		47,30		58,25		74,19	
Reduced heat input (Hi)	kW	5,20	-	5,20	-	8,20	-	8,20	-
Reduced heating capacity (80÷60°C)	kW	4,98	-	4,98	-	7,87	-	7,87	-
Reduced heating capacity (50÷30°C)	kW	5,57	-	5,57	-	8,78	-	8,78	-
DHW									
Nominal heat input (Hi)	kW	34,90		45,00		55,00		70,00	
Nominal heating capacity (*)	kW	34,90		45,00		55,00		70,00	
Reduced heat input (Hi)	kW	5,20	-	5,20	-	8,20	-	8,20	-
Reduced heat output (*)	kW	5,20	-	5,20	-	8,20	-	8,20	-
Modulating ratio		1:7		1:8		1:7		1:8	
EFFICIENCY									
Useful efficiency P max (80÷60°C)	%	97,4		97,5		97,5		97,5	
Useful efficiency P min (80÷60°C)	%	95,8		95,8		96,0		96,0	
Useful efficiency Pn max (50÷30°C)	%	106,9		105,1		105,9		106,0	
Useful efficiency Pn min (50÷30°C)	%	107,2		107,2		107,0		107,0	
Useful efficiency 30% (30°C return)	%	108,2		107,9		107,6		107,5	
Losses in stack with burner ON (Pn max)	%	2,38		2,35		2,41		2,44	
Chimney and skirt losses with burner off	%	0,06		0,05		0,04		0,03	
Losses on casing with burner ON (Pn max)	%	0,22		0,15		0,09		0,06	
FLUE GAS DISCHARGE									
N0x class - UNI EN 15502		6		6		6		6	
Residual head on concentric pipes 0,85m Ø60-100mm	Pa	60		60		ND		ND	
Residual head on separate pipes 0.5m Ø80mm	Pa	160		192		172		197	
Boiler residual head without pipes or flange	Pa	166		198		180		200	

DESCRIPTION	U.M.	CONDEXA HPR 35		CONDEXA HPR 45		CONDEXA HPR 55		CONDEXA HPR 70	
		G20	G31	G20	G31	G20	G31	G20	G31
Type of gas									
ELECTRICAL CHARACTERISTICS									
Max electric power - heating	W	158		175		201		284	
Electric power - burner P max	W	60		77		113		196	
Max electric power - circulator	W	98		98		88		88	
Min electric power - circulator	W	3		3		5		5	
Supply voltage	V - Hz	230-50		230-50		230-50		230-50	
Protection level	IP	X5D		X5D		X5D		X5D	
HEATING OPERATION									
Maximum pressure	bar	5		5		5		5	
Minimum pressure for standard operation	bar	0,8		0,8		0,8		0,8	
Maximum temperature	°C	90		90		90		90	
Selection field for heating water temperature	°C	20/45 - 20/90		20/45 - 20/90		20/45 - 20/90		20/45 - 20/90	
Pump: max head available for the system	mbar	820		820		430		430	
at a flow rate of	l/h	1000		1000		2500		2500	
AIR AND FLUE GAS FLOW RATES									
Heating									
Air flow rate	Nm³/h	42,4	43,3	54,7	55,8	66,8	68,2	85,0	86,9
Flue gas flow rate	Nm³/h	45,9	46,0	59,2	59,3	72,3	72,5	92,0	92,3
Mass flue gas flow rate (max-min)	g/s	15,8-2,4	16,2-2,4	20,4-2,4	20,9-2,4	24,9-3,7	25,5-3,8	31,8-3,7	32,5-3,8
DHW									
Air flow rate	Nm³/h	42,4	43,3	54,7	55,8	66,8	68,2	85,0	86,9
Flue gas flow rate	Nm³/h	45,9	46	59,2	59,3	72,3	72,5	92	92,3
Mass flue gas flow rate (max-min)	g/s	15,8-2,4	16,2-2,4	20,4-2,4	20,9-2,4	24,9-3,7	25,5-3,8	31,8-3,7	32,5-3,8
EMISSIONS AT MAX AND MIN FLOW RATE WITH GAS (**)									
Maximum									
CO s.a. lower than	p.p.m	120	130	150	160	170	170	220	230
CO ₂	%	9,0	10,0	9,0	10,0	9,0	10,0	9,0	10,0
NOx s.a. lower than	p.p.m	50	50	60	60	50	50	60	60
Flue gas temperature	°C	68	66	71	73	66	70	70	76
Minimum									
CO s.a. lower than	p.p.m	30	30	30	30	40	20	40	20
CO ₂	%	9,0	10,0	9,0	10,0	9,0	10,0	9,0	10,0
NOx s.a. lower than	p.p.m	40	45	40	45	40	60	40	60
Flue gas temperature	°C	60	58	60	58	57	58	57	58

(*) Average value with the various DHW operating conditions.

(**) Check carried out with concentric pipe Ø60-100mm, length 0,85m, water temperature 80±60°C.

NOTE

With reference to Delegated Regulation (EU) No. 811/2013, the data in the table can be used to complete the product data sheet and the labelling for room heating appliances, mixed heating appliances, sets of appliances for room heating, temperature control devices and solar devices:

COMPONENT	CLASS	BONUS
OUTDOOR TEMPERATURE SENSOR	II	2%
REMOTE CONTROL OT+	V	3%
OUTDOOR TEMPERATURE SENSOR + REMOTE CONTROL OT+	VI	4%

MODULAR CONDENSING BOILERS

Indoor wall-hung gas condensing modules

ERP TECHNICAL DATA

DESCRIPTION	Symbol	U.M.	CONDEXA HPR 35	CONDEXA HPR 45	CONDEXA HPR 55	CONDEXA HPR 70
Seasonal ambient heating efficiency class			A	A	A	A
Water heating energy efficiency class			ND	ND	ND	ND
Nominal output	Nominal P	kW	34	44	54	68
Seasonal energy efficiency for heating	η_s	%	93	92	92	92
EFFECTIVE HEAT OUTPUT						
At nominal heat output and in high temperature mode (*)	P4	kW	34,0	43,9	53,6	68,2
At 30% of nominal heat output and in low temperature mode (**)	P1	kW	11,3	14,6	17,8	22,6
EFFICIENCY						
At nominal heat output and in high temperature mode (*)	η_4	%	87,7	87,8	87,8	87,8
At 30% of nominal heat output and in low temperature mode (**)	η_1	%	97,4	97,2	96,9	96,8
OTHER PARAMETERS						
Heat loss in standby mode	Pstby	W	36,8	34,7	34,5	34,5
Energy consumption of the pilot light	Pign	W	-	-	-	-
Annual energy consumption	QHE	GJ	105	137	168	214
Sound power level inside	LWA	dB	57	60	57	61
Nitrogen oxide emissions	NOx	mg/kWh	30	33	41	48
FOR COMBINED HEATING APPLIANCES						
Declared load profile			ND	ND	ND	ND
Energy efficiency for water heating	η_{wh}	%	ND	ND	ND	ND
Daily electricity consumption	Qelec	kWh	ND	ND	ND	ND
Daily fuel consumption	Qfuel	kWh	ND	ND	ND	ND
Annual electricity consumption	AEC	kWh	ND	ND	ND	ND
Annual fuel consumption	AFC	GJ	ND	ND	ND	ND

(*) High temperature mode: 60°C on return and 80°C on delivery.

(**) Low temperature mode: 30°C return temperature for condensing boilers, 37°C for low-temperature boilers, 50°C for other heating appliances.

11300-2 DATA – DETERMINATION OF GENERATION LOSSES – CALCULATION METHOD, DIRECTIVE 92/42 EEC

DESCRIPTION	Symbol	U.M.	CONDEXA HPR 35	CONDEXA HPR 45	CONDEXA HPR 55	CONDEXA HPR 70
Nominal useful heating capacity	Fgn,Pn	kW	34,00	43,88	53,60	68,22
Efficiency at nominal capacity	hgn,pn	--	97,4	97,5	97,5	97,5
Average temperature at Pn	qgn,test,pn	°C	70	70	70	70
Useful heating capacity at 30%	Fint	kW	5,20	5,20	8,20	8,20
Efficiency at 30% capacity	hgn,Pint	--	108,2	107,9	107,6	107,5
Average temperature at intermediate P	qgn,test,Pint	°C	40	40	40	40
Capacity lost with null load with Dqgn,test	Fgn,1,P0	W	36,8	34,7	34,5	34,5
Input power for auxiliary devices at nominal load	Wgn,aux,Pn	W	48	86	103,4	184,9
Input power for auxiliary devices at intermediate load	Wgn,aux,Pint	W	13	15	21,1	25,6
Input power for auxiliary devices at null load	Wgn,aux,P0	W	3,8	3,8	3,8	3,8
Minimum return temperature on generator	qgn,min	°C	20	20	20	20

TABLE LAW 10

DESCRIPTION	U.M.	CONDEXA HPR 35		CONDEXA HPR 45		CONDEXA HPR 55		CONDEXA HPR 70	
		G20	G31	G20	G31	G20	G31	G20	G31
Type of gas									
MAXIMUM HEATING CAPACITY									
Effective (80÷60°C)	kW	34,00		43,88		53,60		68,22	
Effective (50÷30°C)	kW	37,31		47,30		58,25		74,19	
Furnace	kW	34,90		45,00		55,00		70,00	
MINIMUM HEATING CAPACITY									
Effective (80÷60°C)	kW	4,98		4,98		7,87		7,87	
Effective (50÷30°C)	kW	5,57		5,57		8,78		8,78	
Furnace	kW	5,20		5,20		8,20		8,20	
EFFICIENCY									
Useful efficiency Pn max - Pn min (80÷60°C)	%	97,4		97,5		97,5		97,5	
Useful efficiency Pn max - Pn min (50÷30°C)	%	106,9		105,1		105,9		106	
Useful efficiency 30% (30°C return)	%	108,2		107,9		107,6		107,5	
Losses in stack with burner ON (Pn max)	%	2,38		2,35		2,41		2,44	
Chimney and skirt losses with burner off	%	0,06		0,05		0,04		0,03	
Losses on casing with burner ON (Pn max)	%	0,22		0,15		0,09		0,06	
EMISSIONS AT MAX AND MIN FLOW RATE WITH GAS (*)									
Maximum									
CO s.a. lower than	p.p.m	120	130	150	160	170	170	220	230
CO ₂	%	9,0	10,0	9,0	10,0	9	10	9	10
NOx s.a. lower than	p.p.m	50	50	60	60	50	50	60	60
Flue gas temperature	°C	68	66	71	73	66	70	70	76
Minimum									
CO s.a. lower than	p.p.m	30	30	30	30	40	20	40	20
CO ₂	%	9,0	10,0	9,0	10,0	9	10	9	10
NOx s.a. lower than	p.p.m	40	45	40	45	40	60	40	60
Flue gas temperature	°C	60	58	60	58	57	58	57	58
NOx class		6		6		6		6	
Electric power (max Pel heat-max Pel DHW)	W	158		158		201		284	

(*) Check carried out with concentric pipe Ø60-100mm, length 0,85m, water temperature 80÷60°C.

MODULAR CONDENSING BOILERS

Indoor wall-hung gas condensing modules

FLOW RATE-DISCHARGE HEAD DIAGRAMS

CONDEXA HPR 35 - 45

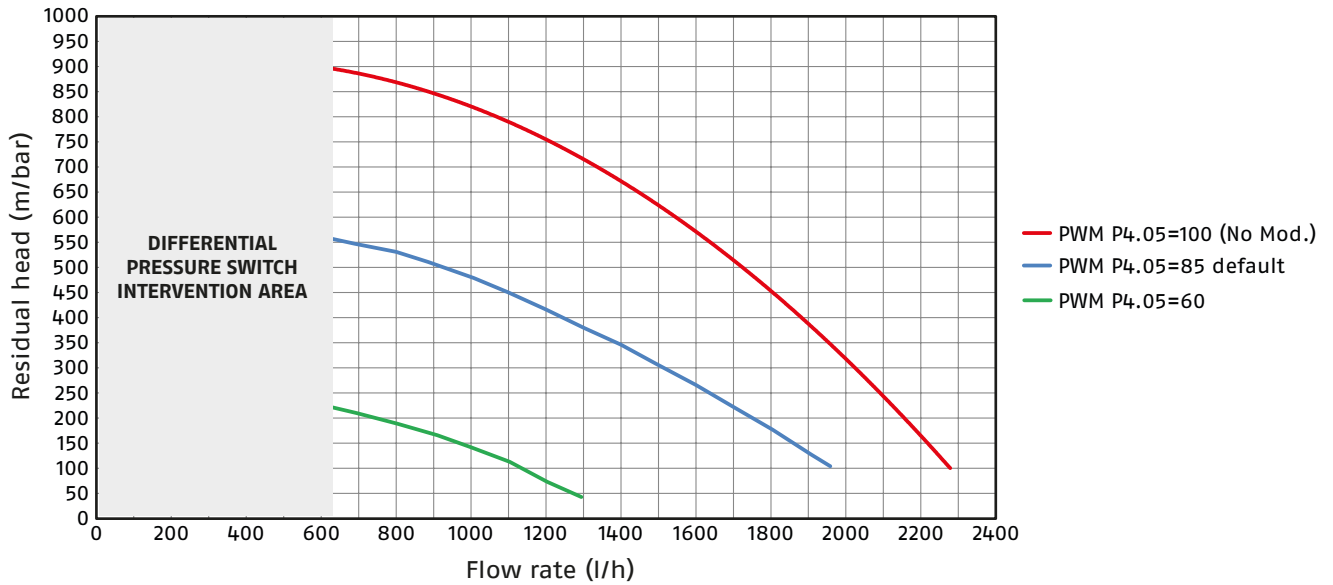

CONDEXA HPR 55 - 70

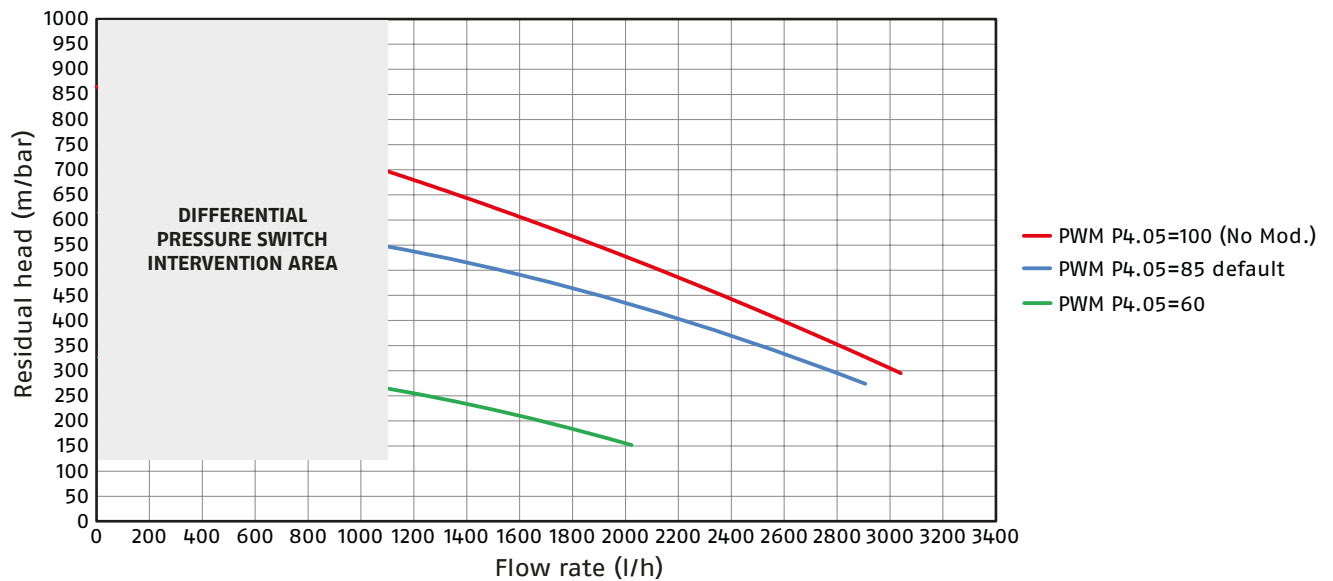

THE WATER IN THE HEATING SYSTEMS

CHEMICAL AND PHYSICAL CHARACTERISTICS

The chemical and physical characteristics of the water must comply with European standard EN 14868 and the following tables:

PARAMETERS	U.M.	HEATING CIRCUIT WATER	FILLING WATER
pH value		7-8	-
Hardness	°F	-	< 15
Appearance		-	clear
Fe	mg/kg	< 0,5	-
Cu	mg/kg	< 0,1	-

OVERALL DIMENSIONS AND WEIGHTS

CONDEXA HPR 35 - 45

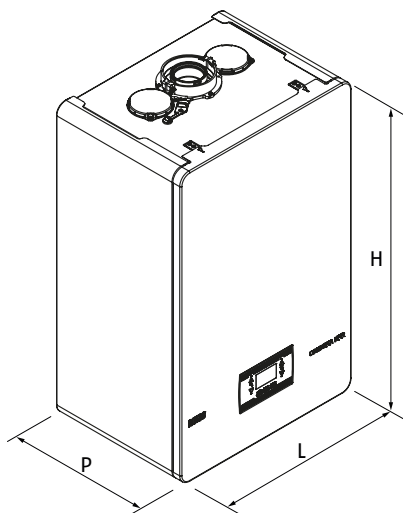

CONDEXA HPR 55 - 70

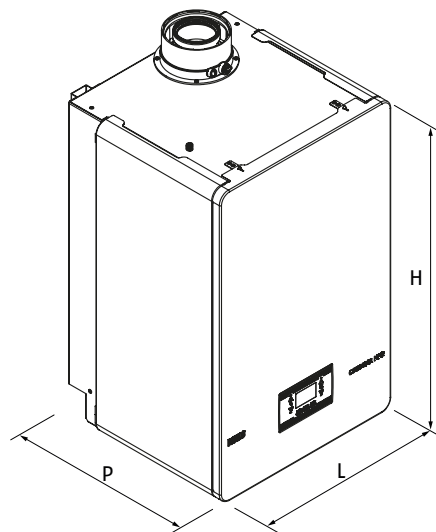

DESCRIPTION	U.M.	CONDEXA HPR 35	CONDEXA HPR 45	CONDEXA HPR 55	CONDEXA HPR 70
L	mm	470	470	470	470
P	mm	350	350	443	443
H	mm	740	740	740	740
Net weight	kg	35	35	53,5	53,5

MINIMUM INSTALLATION DISTANCES

The CONDEXA HPR boiler can be installed in permanently ventilated rooms that have suitably sized ventilation openings complying with the Technical Standards and Regulations applicable to the installation site. The appliance can be installed indoors or outdoors in a partially protected place (i.e. where it is not exposed to direct contact with - or infiltration of - rain, snow or hail). It can work in a temperature range from >0°C to +60°C. Consider the clearances necessary to access the safety and adjustment devices and to perform maintenance operations.

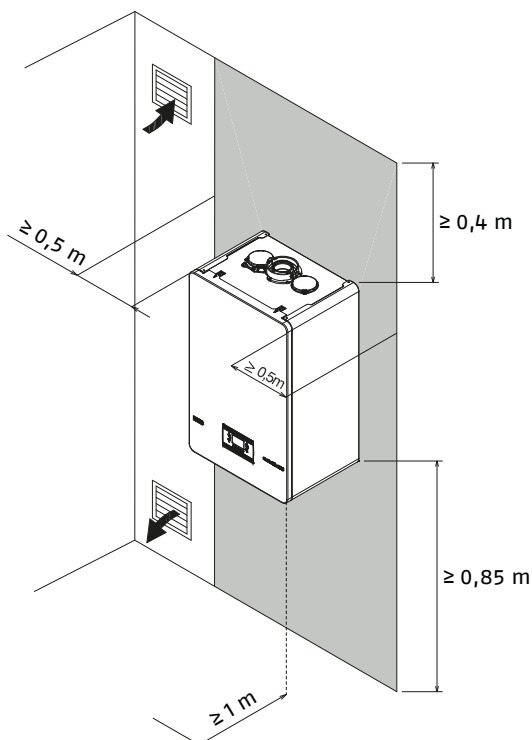

MODULAR CONDENSING BOILERS

Indoor wall-hung gas condensing modules

STRUCTURE

CONDEXA HPR 35 - 45

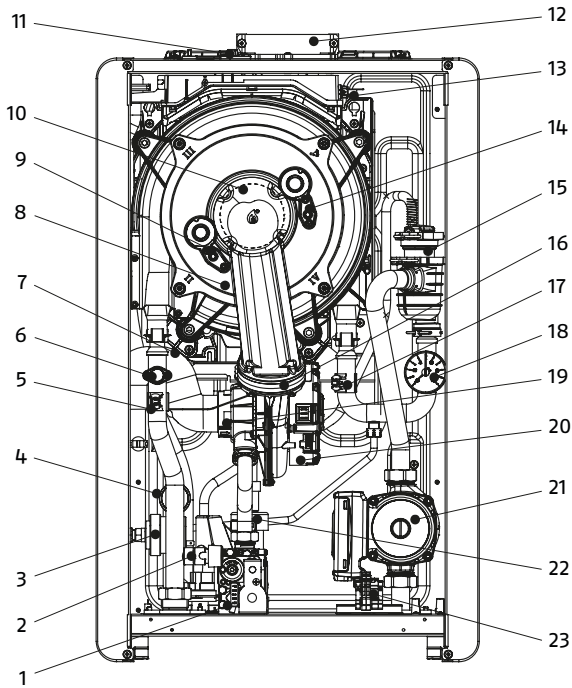

1. Gas valve
2. Degassing unit tap
3. Differential heating pressure switch
4. Pressure transducer with minimum pressure function
5. Safety thermostat with manual reset (board reset)
6. NTC delivery probe
7. Suction line
8. Heat exchanger
9. Detection electrode
10. Burner
11. Flue gas analysis outlet
12. Flue gas discharge
13. Flue gas probe
14. Ignition electrode
15. Air vent valve
16. Check valve
17. NTC return line probe
18. Pressure gauge
19. Mixer
20. Fan
21. Circulator
22. Drain-trap
23. Power supply connector

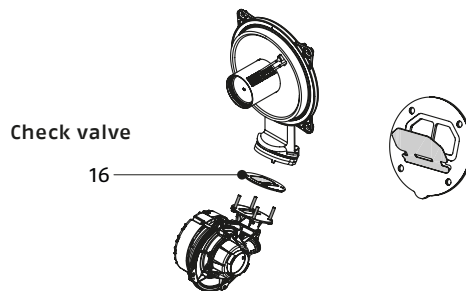

CONDEXA HPR 55 - 70

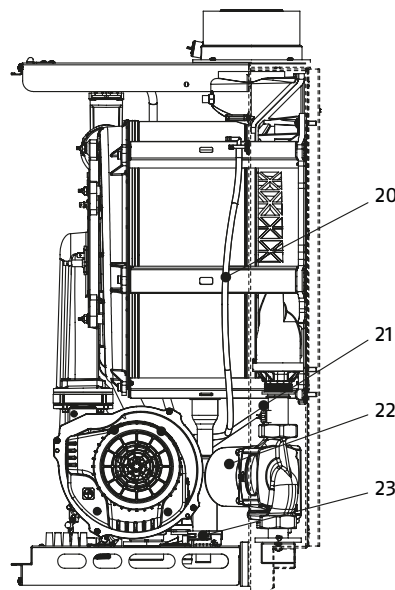
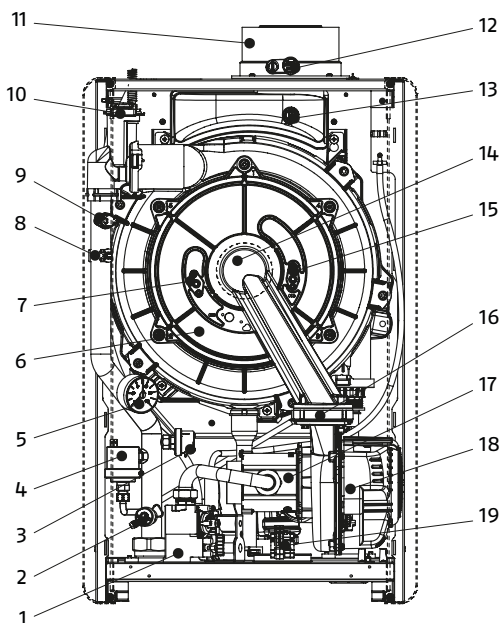

1. Gas valve
2. Degassing unit tap
3. Pressure transducer with minimum pressure function
4. Heating pressure switch
5. Pressure gauge
6. Heat exchanger
7. Detection electrode
8. NTC delivery probe
9. Safety thermostat with manual reset by means of a board reset
10. Air vent valve
11. Flue gas discharge
12. Flue gas analysis outlet
13. Flue gas probe
14. Burner
15. Ignition electrode
16. Check valve
17. Mixer
18. Fan
19. Power supply wiring
20. Atmospheric silicon tube
21. NTC return line probe
22. Circulator
23. Drain-trap

HYDRAULIC CIRCUIT AND CONNECTIONS

CONDEXA HPR 35 - 45

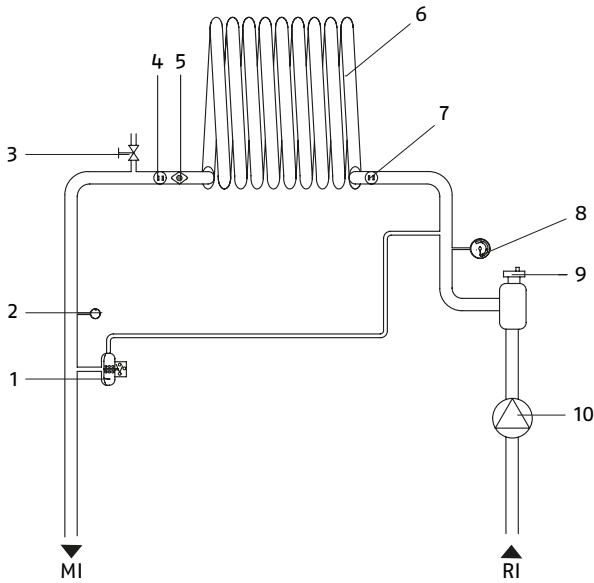

- 1. Heating pressure switch
- 2. Pressure transducer
- 3. Degassing unit tap
- 4. Safety thermostat
- 5. Flow sensor
- 6. Heat exchanger
- 7. Return probe

CONDEXA HPR 55 - 70

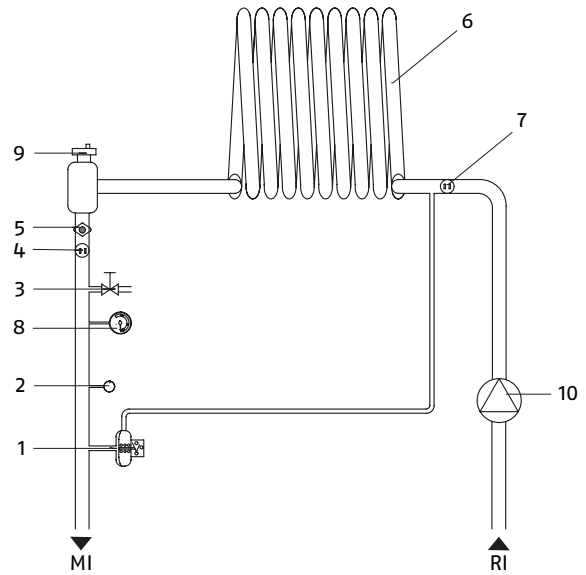

- 8. Pressure gauge
 - 9. Air vent valve
 - 10. Circulator
- MI Heating delivery line
RI Heating return line

CONDEXA HPR 35 - 45

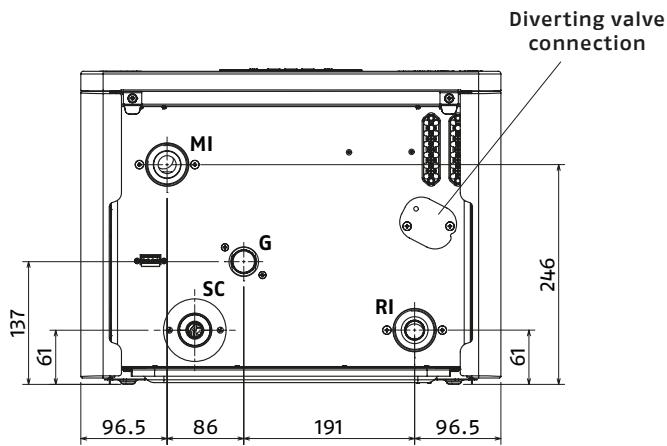

CONDEXA HPR 55 - 70

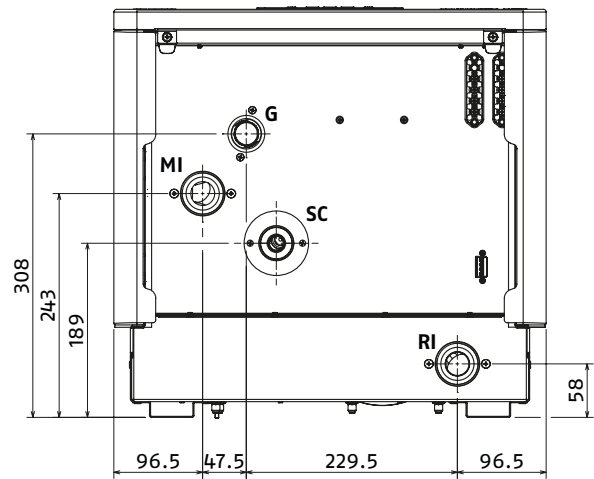

DESCRIPTION	U.M.	CONDEXA HPR 35	CONDEXA HPR 45	CONDEXA HPR 55	CONDEXA HPR 70
MI (system delivery)	∅	G 1" 1/2 M	G 1" 1/2 M	G 1" 1/2 M	G 1" 1/2 M
RI (system return)	∅	G 1" 1/2 M	G 1" 1/2 M	G 1" 1/2 M	G 1" 1/2 M
SC (condensate discharge)	∅ mm	25	25	25	25
G (gas inlet)	∅	G 3/4" M	G 3/4" M	G 3/4" M	G 3/4" M
Diverting valve connection	∅	G 1" 1/2 M	G 1" 1/2 M	-	-

MODULAR CONDENSING BOILERS

Indoor wall-hung gas condensing modules

SCHEMA OF HYDRAULIC SYSTEMS

Layout 1: circuit with boiler directly connected to heating system (check that the pump head is sufficient to ensure adequate circulation)

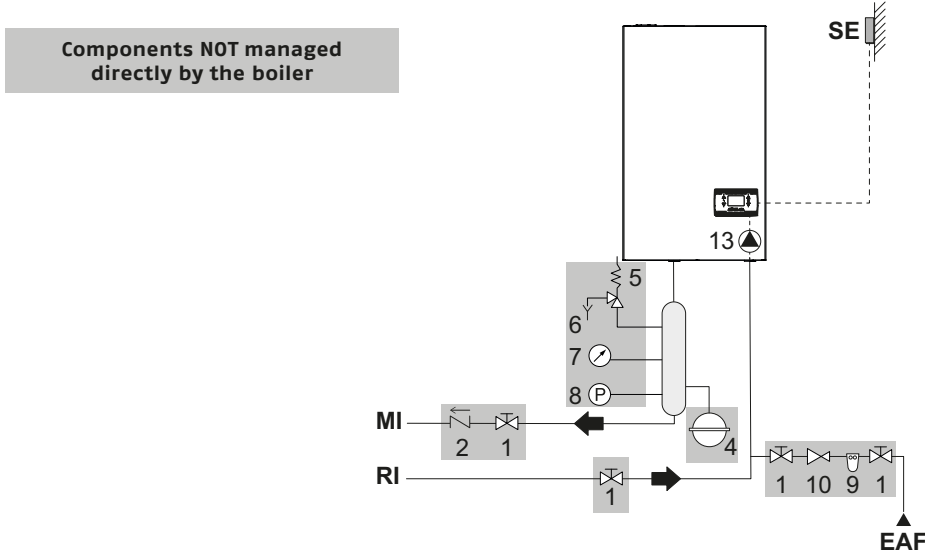

Layout 2: circuit with boiler directly linked to heating system and DHW tank (check that the pump head is sufficient to ensure adequate circulation)

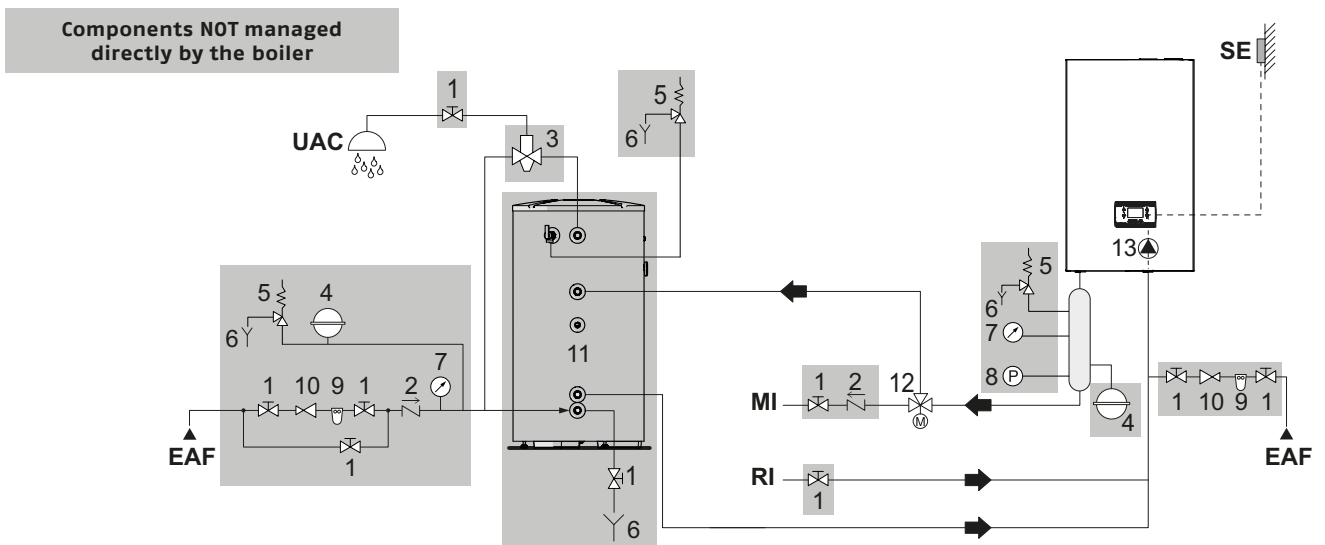

- | | |
|-----|----------------------------------|
| 1. | Disconnecter valve |
| 2. | Non-return valve |
| 3. | Anti-burn mixer valve |
| 4. | Expansion vessel |
| 5. | Safety valve |
| 6. | Discharge |
| 7. | Pressure gauge |
| 8. | Minimum pressure switch |
| 9. | Softener filter |
| 10. | Pressure reducer |
| 11. | Storage tank |
| 12. | Diverting valve |
| 13. | Boiler circulator |
| SE | Outdoor temperature sensor |
| MI | High-temperature system delivery |
| RI | High-temperature system return |
| EAF | Cold water inlet |
| UAC | DHW outlet |

- ⚠** The DHW and heating circuits must be completed with expansion vessels of adequate capacity and correctly-sized safety valves. The outlet of the safety valves and appliances must be connected to a suitable collection and evacuation system (refer to the price list catalogue for the accessories that can be fitted).
- ⚠** The choice and installation of the system components is the responsibility of the installer, who must respect the good practice standards and current legislation.
- ⚠** Special supply/make-up water must be conditioned using suitable treatment systems.
- ⊘** It is forbidden to operate the boiler and circulators without water.
- ⚠** On CONDEXA HPR 35-45 models, the diverting valve (12) can be installed in the boiler.

Layout 3: circuit with boiler connected to heating system via separator

Components NOT managed directly by the boiler

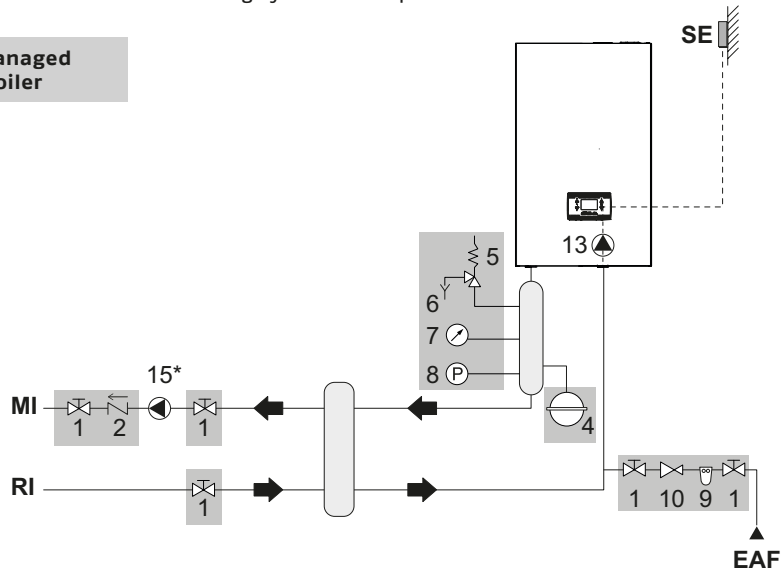

Layout 4: circuit with boiler connected to DHW tank and heating system via separator

Components NOT managed directly by the boiler

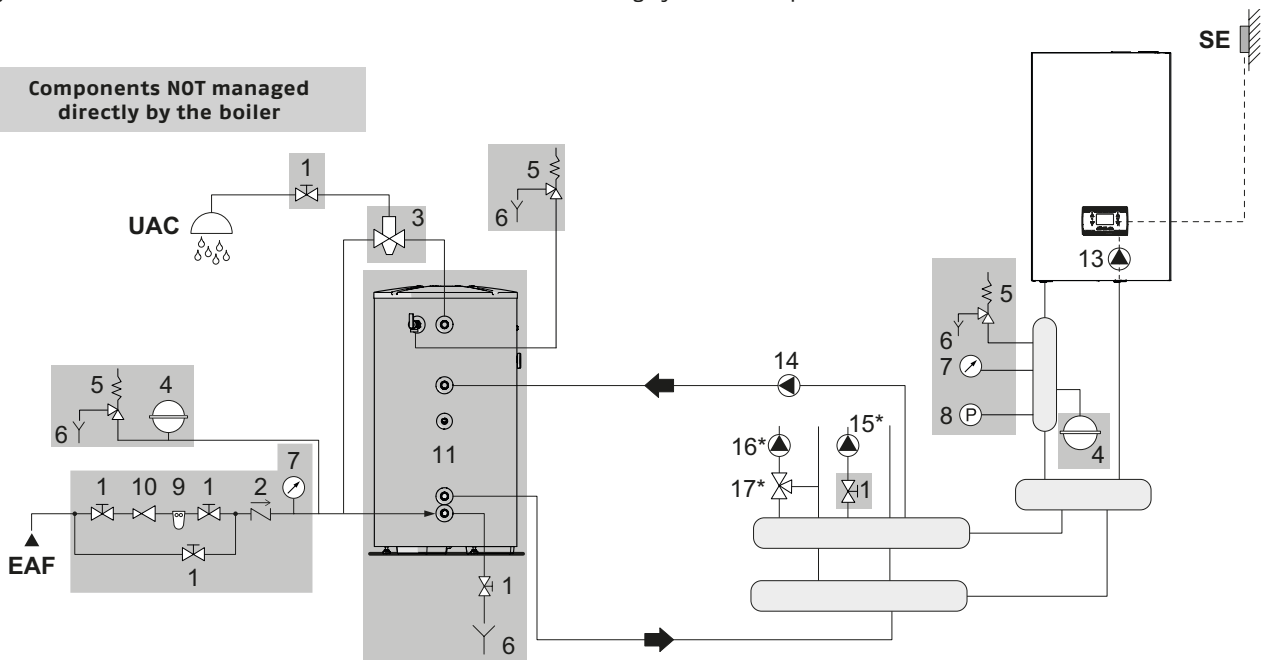

- 1. Disconnecter valve
- 2. Non-return valve
- 3. Anti-burn mixer valve
- 4. Expansion vessel
- 5. Safety valve
- 6. Discharge
- 7. Pressure gauge
- 8. Minimum pressure switch
- 9. Softener filter
- 10. Pressure reducer
- 11. Storage tank
- 12. Diverting valve
- 13. Boiler circulator
- 14. Storage tank circulator
- 15. Direct zone circulator *managed by boiler with specific accessory)
- 16. Mixed zone circulator *managed by boiler with specific accessory)
- 17. Mixer valve *managed by boiler with specific accessory)
- SE Outdoor temperature sensor
- MI High-temperature system delivery
- RI High-temperature system return
- EAF Cold water inlet
- UAC Domestic hot water outlet

⚠ The DHW and heating circuits must be completed with expansion vessels of adequate capacity and correctly-sized safety valves. The outlet of the safety valves and appliances must be connected to a suitable collection and evacuation system (refer to the price list catalogue for the accessories that can be fitted).

⚠ The choice and installation of the system components is the responsibility of the installer, who must respect the good practice standards and current legislation.

⚠ Special supply/make-up water must be conditioned using suitable treatment systems.

⊖ It is forbidden to operate the boiler and circulators without water.

MODULAR CONDENSING BOILERS

Indoor wall-hung gas condensing modules

Layout 5: circuit with boiler connected to heating system and DHW tank via separator

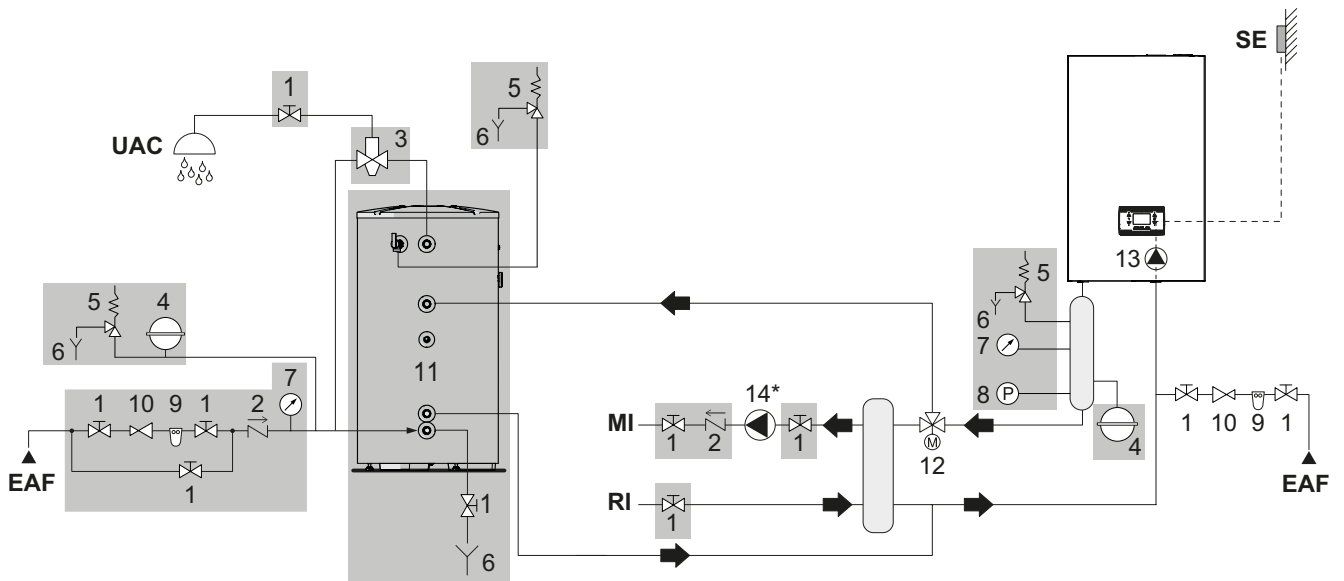

- | | |
|-----|--|
| 1. | Disconnecter valve |
| 2. | Non-return valve |
| 3. | Anti-burn mixer valve |
| 4. | Expansion vessel |
| 5. | Safety valve |
| 6. | Discharge |
| 7. | Pressure gauge |
| 8. | Minimum pressure switch |
| 9. | Softener filter |
| 10. | Pressure reducer |
| 11. | Storage tank |
| 12. | Diverting valve |
| 13. | Circulator |
| 14. | High-temperature system circulator *managed by boiler with specific accessory) |
| SE | Outdoor temperature sensor |
| MI | High-temperature system delivery |
| RI | High-temperature system return |
| EAF | Cold water inlet |
| UAC | Domestic hot water outlet |

- ⚠** The DHW and heating circuits must be completed with expansion vessels of adequate capacity and correctly-sized safety valves. The outlet of the safety valves and appliances must be connected to a suitable collection and evacuation system (refer to the price list catalogue for the accessories that can be fitted).
- ⚠** The choice and installation of the system components is the responsibility of the installer, who must respect the good practice standards and current legislation.
- ⚠** Special supply/make-up water must be conditioned using suitable treatment systems.
- ⊖** It is forbidden to operate the boiler and circulators without water.
- ⚠** On CONDEXA HPR 35-45 models, the diverting valve (12) can be installed in the boiler.

ELECTRICAL WIRING

The CONDEXA HPR thermal module leaves the factory fully wired, and only needs to be connected to the main power supply and the system components.

It is compulsory to use an omnipolar magnetothermal switch (a line disconnector) complying with CEI-EN standards (contact opening of at least 3mm).

The supply cable is not supplied as standard. The connection to the mains supply must be made using FR0R 3G1.5 type cables (standardised by CEI 20-27) or the equivalent.

It is also advisable to respect the phase-neutral connection (L-N).

You are advised to use wires with a section no larger than 0,5mm² for the low voltage connections.

NOTE: L-N CONNECTION IS ADVISABLE

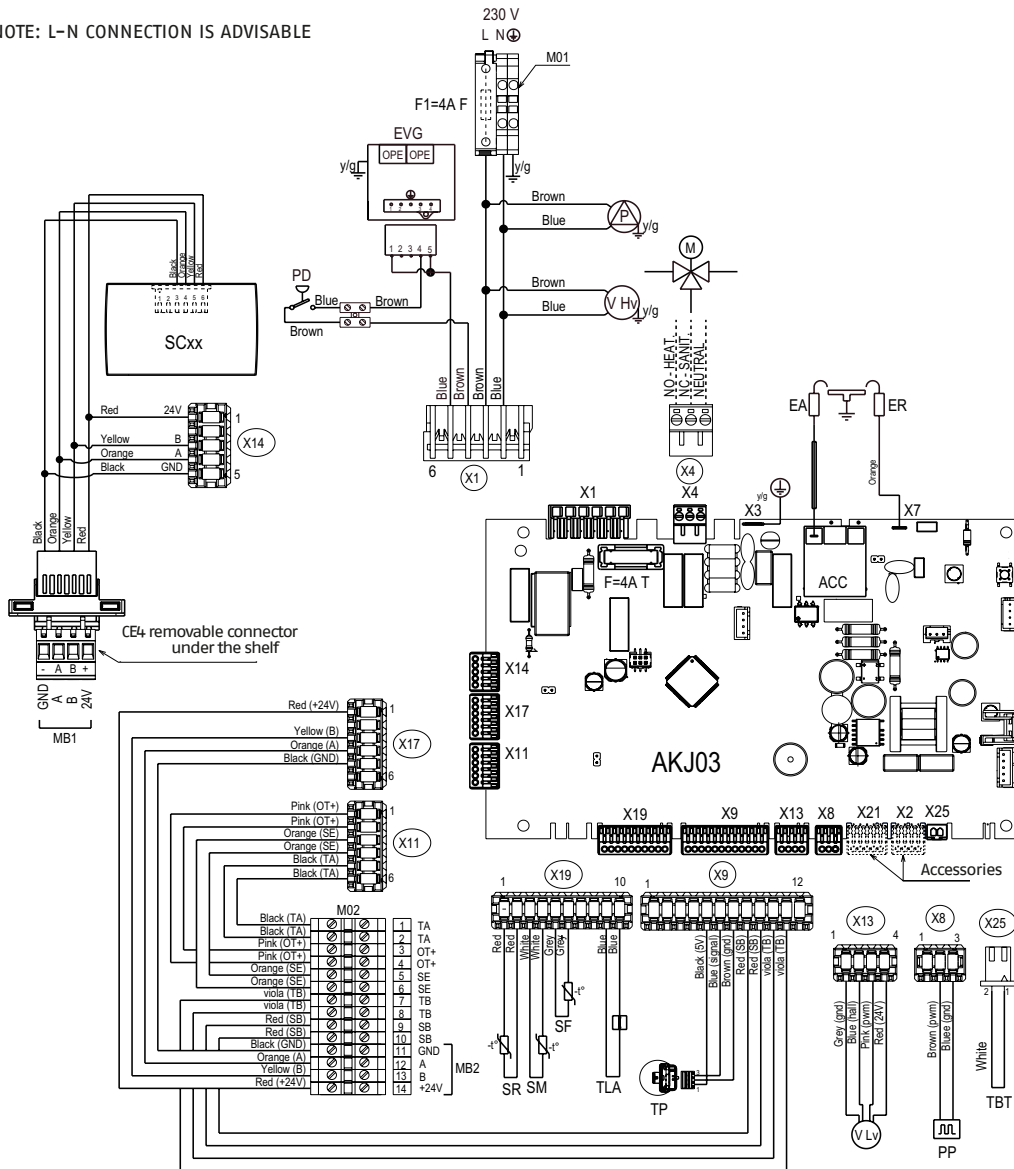

- AKJ03 Control board with built-in ignition transformer
- SC User interface
- F Fuse
- F1 External fuse 4A F
- X1-X25 Connection fittings
- ACC Ignition transformer
- EA Ignition electrode
- ER Detection electrode
- V Hv 230V fan power supply
- M 3-way valve
- P Pump
- PD Differential pressure switch
- PP PWM signal for pump command
- V Lv PWM signal for fan command
- TP Pressure transducer
- SR Return probe
- SM Flow probe
- TLA Safety thermostat

- SF Flue gas probe
- EVG Gas valve
- M 3-way valve
- M01 Power supply terminal board (high voltage)
- M02 Terminal board for connection of external services (low voltage)
- MB1 Modbus 1: commands/wi-fi key
- MB2 Modbus 2: cascades
- SB Storage cylinder probe
- TB Storage tank thermostat
- TA Room thermostat
- OT+ Open therm
- SE Outdoor temperature sensor
- CE4 Modbus 1 connector
- X4 Connection for hydraulic 3-way valve (available upon request from the Riello Product Catalogue)
- X2 Remote alarm (accessory)
- X21 Zone valve or additional pump (accessory)

MODULAR CONDENSING BOILERS

Indoor wall-hung gas condensing modules

CONTROL PANEL

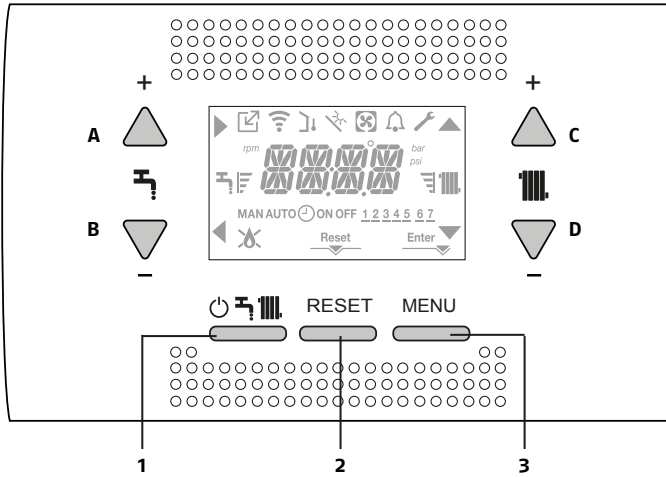

The control panel acts as a machine interface, displaying the system settings and providing access to the parameters.

The display normally shows the temperature of the delivery probe, but if there is an active DHW request it shows the DHW probe temperature. If no button is touched for 10 seconds, the interface shows the current time (backlight OFF).

The configuration MENU is organised with a multi-level tree structure. An access level has been fixed for each sub-menu: USER level always available; TECHNICAL level protected by means of a password. Some of the information might not be available depending on the access level, machine status or system configuration.

The DHW function is only shown on the display in cases B and C.

Function of the buttons

A	Normally used to increase the DHW temperature value, but when the arrow ► is highlighted it acts as a confirmation button
B	Normally used to decrease the DHW temperature value, but when the arrow ◀ is highlighted it acts as a back/annul button
C	Normally used to increase the heating water temperature value, but when the arrow ▲ is highlighted it allows you to navigate menu P1
D	Normally used to decrease the heating water temperature value, but when the arrow ▼ is highlighted it allows you to navigate menu P1
A+C	Access to the clock setting menu
1	Used to modify the boiler operating status (OFF, SUMMER and WINTER)
2	Used to reset the alarm status, or to interrupt the venting cycle
3	Used to access the INFO and P1 menus. When the Enter icon appears on the display, this button has an ENTER function and is used to confirm the value set while programming a technical parameter
1+3	Button lock and release
2+3	Used when the boiler is OFF, to activate the combustion analysis function (CO)

Description of the icons

	Indicates the connection to a remote device (OT or RS485)
	Indicates the connection to a wi-fi device
	Indicates the presence of an outdoor temperature sensor
	Indicates the activation of special DHW functions, or the presence of a solar thermal management system
	Lights up if an alarm is triggered
	Lights up along with the alarm bell icon in the event of a fault (apart from flame and water alarms)
	Indicates the presence of a flame (X in the event of a flame lockout)
	Lights up in the event of alarms requiring a manual reset by the operator
	Lights up when confirmation is required
	When this icon is active, the "confirm" function of button A is active
	When this icon is active, the "back/annul" function of button B is active
	When this icon is active, the user can navigate the menu or increase the value of the selected parameter
	When this icon is active, the user can navigate the menu or decrease the value of the selected parameter
	Lights up if heating mode is active; flashes when there is a heating request in progress
	Lights up if DHW mode is active; flashes when there is a DHW request in progress
	Indicate the setpoint defined (1 notch=minimum value, 4 notches=maximum value)
1 2 3 4 5 6 7	Indicate the days of the week
AUTO	Not available on this model
MAN ON	Not available on this model
MAN OFF	Not available on this model

FLUE GAS DISCHARGE AND COMBUSTION AIR INTAKE

For the evacuation of the combustion products, refer to standard UNI 7129-7131. Always comply with the local regulations of the fire brigade and gas company, and any possible municipal regulations. It is essential for flue gas evacuation and boiler combustion air transfer that only original pipes are used (apart from type C6, as long as it is certified), and that the connection is made as explained in the instructions supplied with the flue gas accessories. A single flue can be connected to several appliances provided that every appliance is of the condensing type.

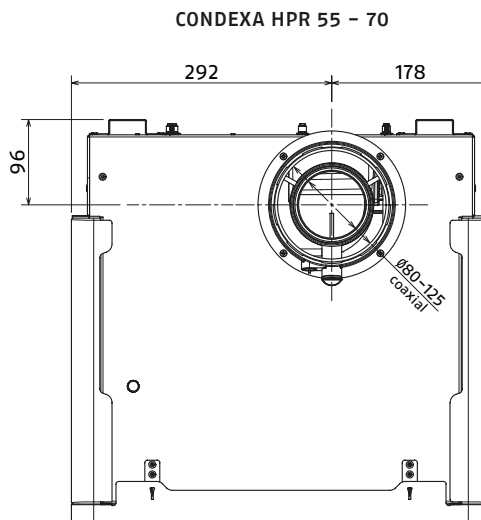
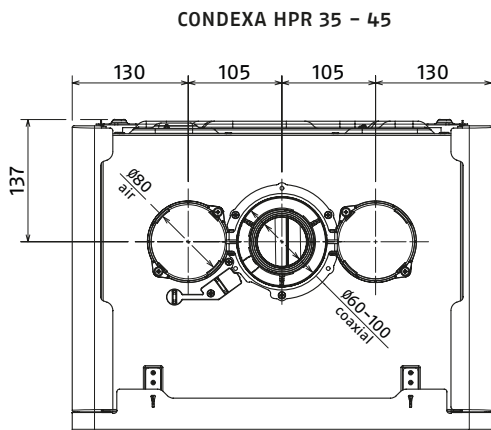

Type of discharge	Maximum straight length (m)				Pressure drops for each bend inserted (m)	
	HPR 35	HPR 45	HPR 55	HPR 70	45°	90°
Flue gases pipe Ø80 mm ("forced open" installation) (type B23P-B53P)	48	33	17	13	1	1,5
Coaxial pipe Ø60-100mm	10	10	-	-	1,3	1,6
Coaxial pipe Ø80-125mm	25	25	10	10	1	1,5
Twin pipe Ø80mm (fixed or with adapter)	30+30	21+21	12+12	10+10	1	1,5

CONDEXA HPR 35 - 45

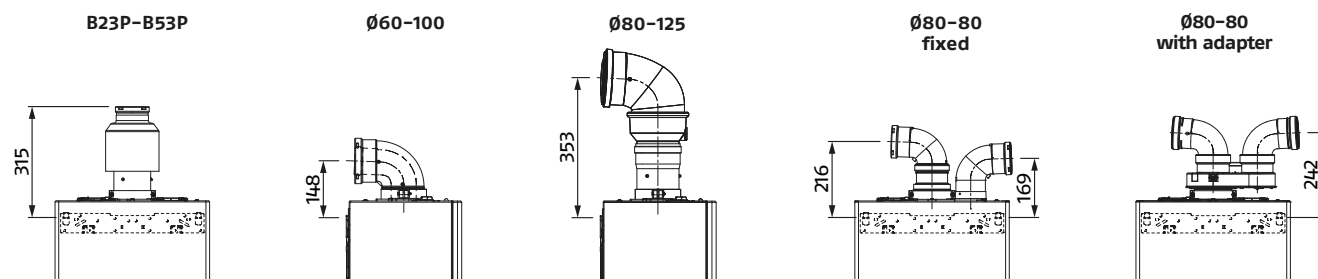

CONDEXA HPR 55 - 70

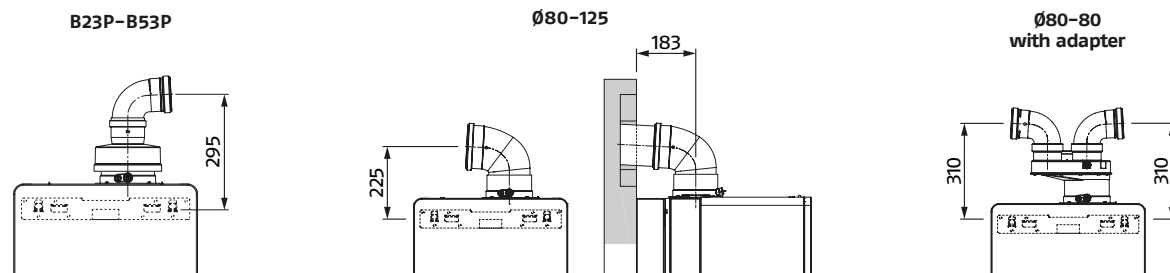

MODULAR CONDENSING BOILERS

Indoor wall-hung gas condensing modules

For the maximum lengths of the individual flues in the case of separate flues $\varnothing 80-80$ mm, refer to the following charts.

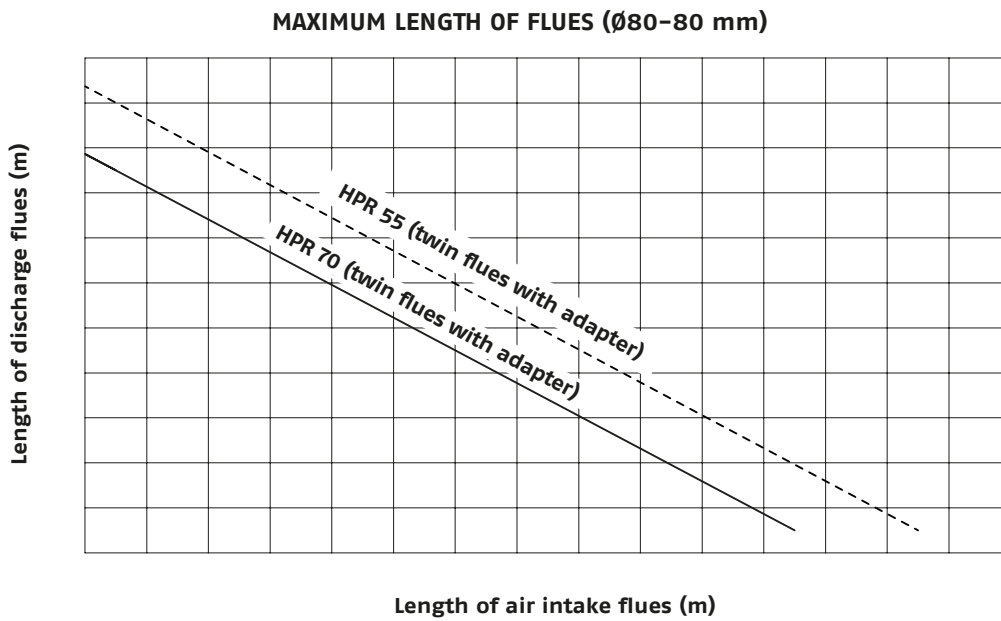
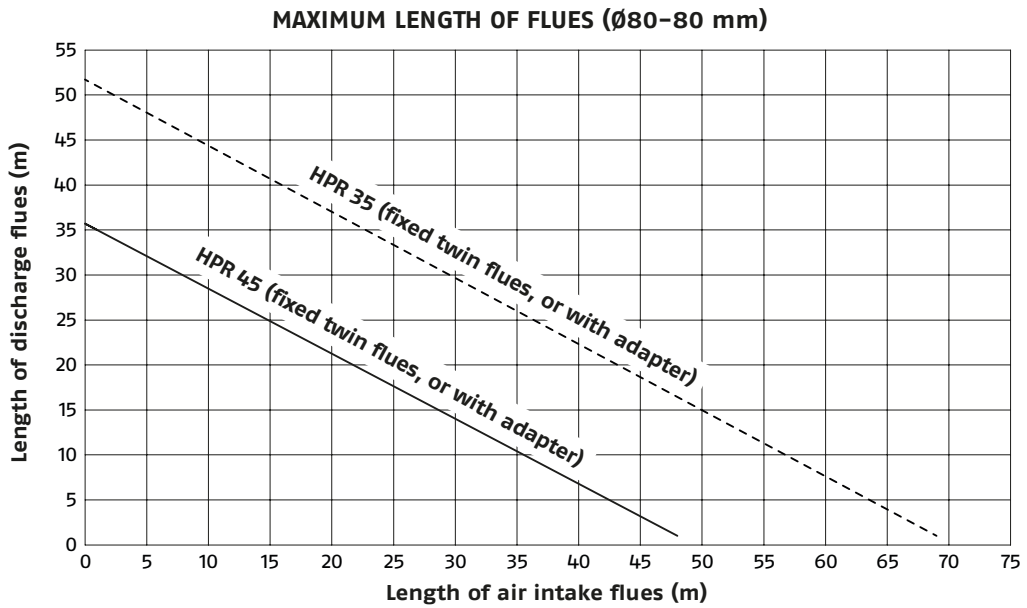

CONDEXA HPR system (cascade installation)

CONDEXA HPR can be combined with other generators in cascade installation, creating modular heating plants formed of hydraulically connected thermal modules whose electronic controls communicate via the Bus. Each thermal module is, in fact, designed to be combined with other identical ones, up to a maximum of 4 units and 272 kW.

For each thermal module, the installation can be linear (i.e. Front) or back-to-back.

Whatever the power level or number of thermal modules, Condexa HPR can be installed with a left-hand or right-hand configuration.

- Continuity of service is guaranteed by system modularity: even in the event of a fault on a module, overall operation will not be compromised.
- The anti-freeze and anti-seizing functions ensure operation in all weather conditions.
- Maximum operating pressure: 5 bar.
- There is a wide range of accessories to ensure the simple, fast and complete installation in cascade form.

Linear cascade (FRONT)

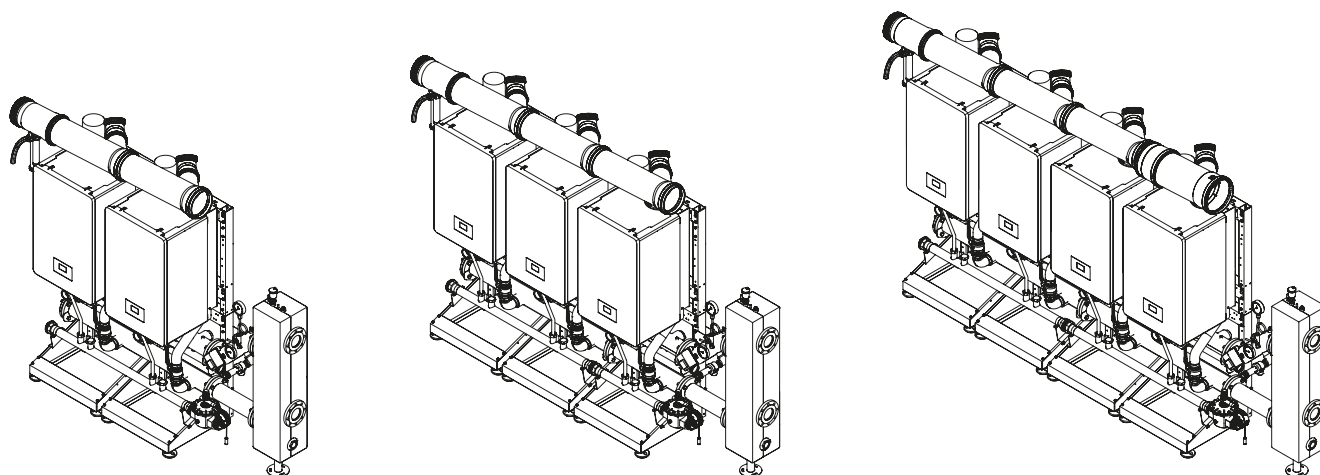

Back-to-back cascade (B2B)

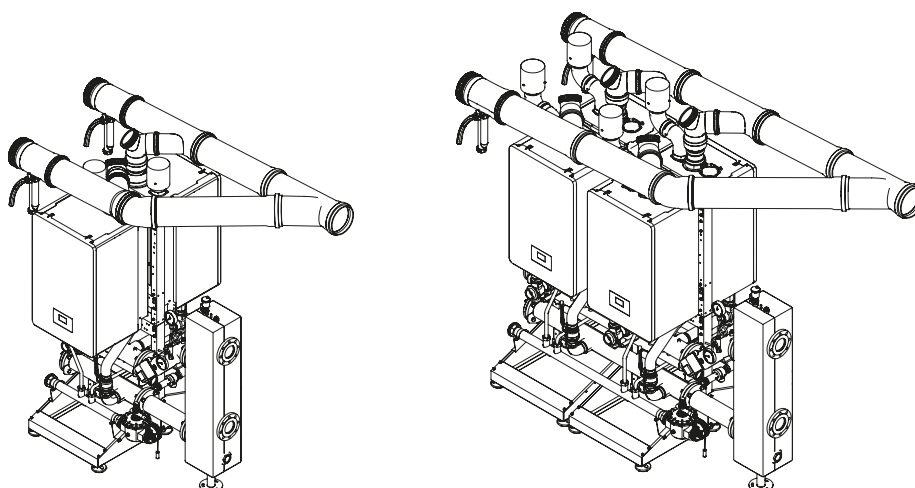

MODEL	CONDEXA HPR 35	CONDEXA HPR 45	CONDEXA HPR 55	CONDEXA HPR 70
No. of thermal modules	Total cascade output (kW)			
1	34.9	45	57	68
2	70	90	114	136
3	105	135	171	204
4	140	180	228	272

MODULAR CONDENSING BOILERS

Indoor wall-hung gas condensing modules

CASCADE CONFIGURATIONS

Linear cascade (FRONT) 2 modules - [35-45kW]

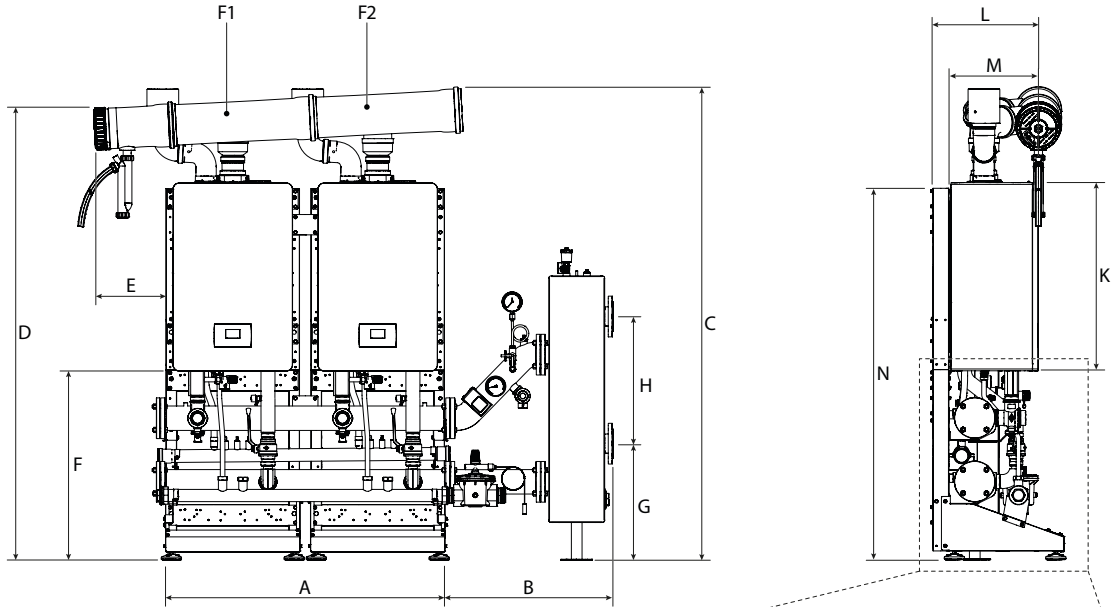

If the plate heat exchanger is present (instead of the hydraulic compensator), the reference dimensions are:

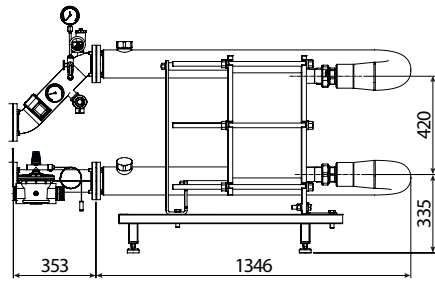

dimension B = 1,699 mm (instead of 658 mm).

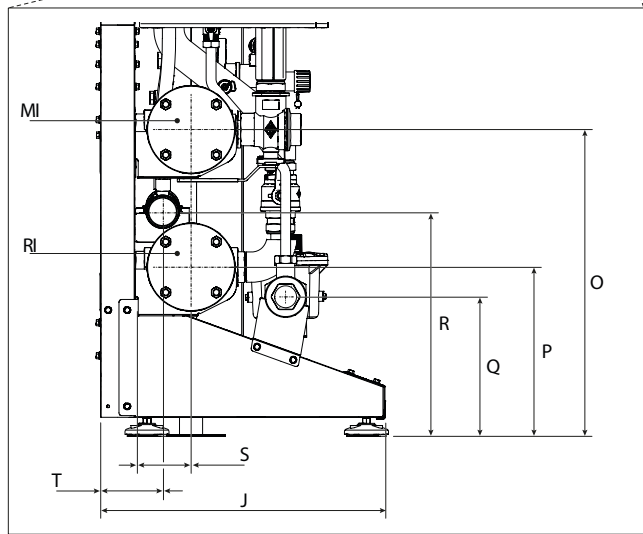

DESCRIPTION	A	B	C	D	E	F	G	H	J	K	L	M
CONDEXA HPR 35	1100	658	1860	1777	285	743	457	500	525	740	423	351
CONDEXA HPR 45	1100	658	1860	1777	285	743	457	500	525	740	423	351
UM	mm	mm	mm	mm	mm	mm	mm	mm	mm	mm	mm	mm

DESCRIPTION	N	O	P	Q	R	S	T	F1	F2	RI*	MI*
CONDEXA HPR 35	1483	558	308	254	408	103	113	Ø160	Ø160	Ø2"½	Ø2"½
CONDEXA HPR 45	1483	558	308	254	408	103	113	Ø160	Ø160	Ø2"½	Ø2"½
UM	mm	mm	mm	mm	mm	mm	mm	mm	mm	inch	inch

(*) Primary and secondary flange DN65 PN6 - 4 holes.

Linear cascade (FRONT) 2 modules - [55-70kW]

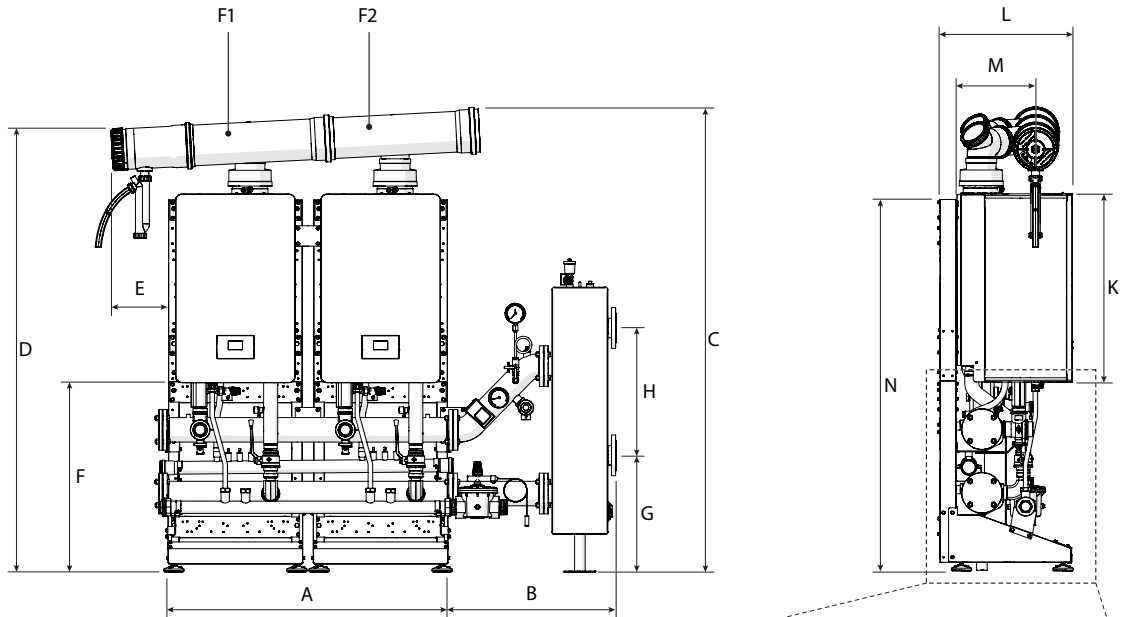

If the plate heat exchanger is present (instead of the hydraulic compensator), the reference dimensions are:

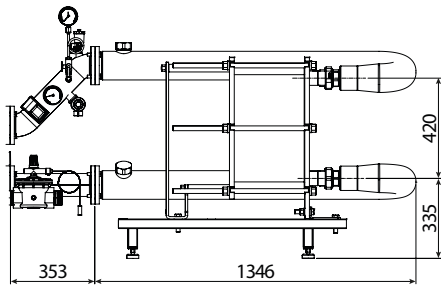

dimension B = 1,699 mm (instead of 658 mm).

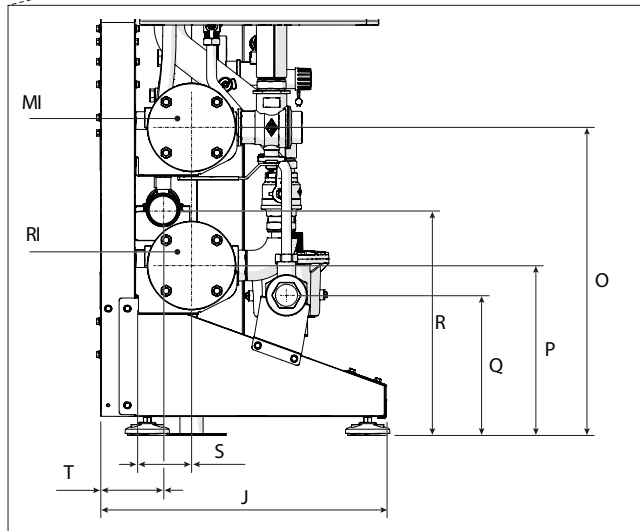

DESCRIPTION	A	B	C	D	E	F	G	H	J	K	L	M
CONDEXA HPR 55	1100	658	1824	1740	226	743	457	500	525	740	516	312
CONDEXA HPR 70	1100	658	1824	1740	226	743	457	500	525	740	516	312
UM	mm	mm	mm	mm	mm	mm	mm	mm	mm	mm	mm	mm

DESCRIPTION	N	O	P	Q	R	S	T	F1	F2	RI*	MI*
CONDEXA HPR 55	1481	558	228	254	408	103	113	Ø160	Ø160	Ø2"½	Ø2"½
CONDEXA HPR 70	1481	558	228	254	408	103	113	Ø160	Ø160	Ø2"½	Ø2"½
UM	mm	mm	mm	mm	mm	mm	mm	mm	mm	inch	inch

(*) Primary and secondary flange DN65 PN6 - 4 holes.

MODULAR CONDENSING BOILERS

Indoor wall-hung gas condensing modules

Linear cascade (FRONT) 3 modules - [35-45kW]

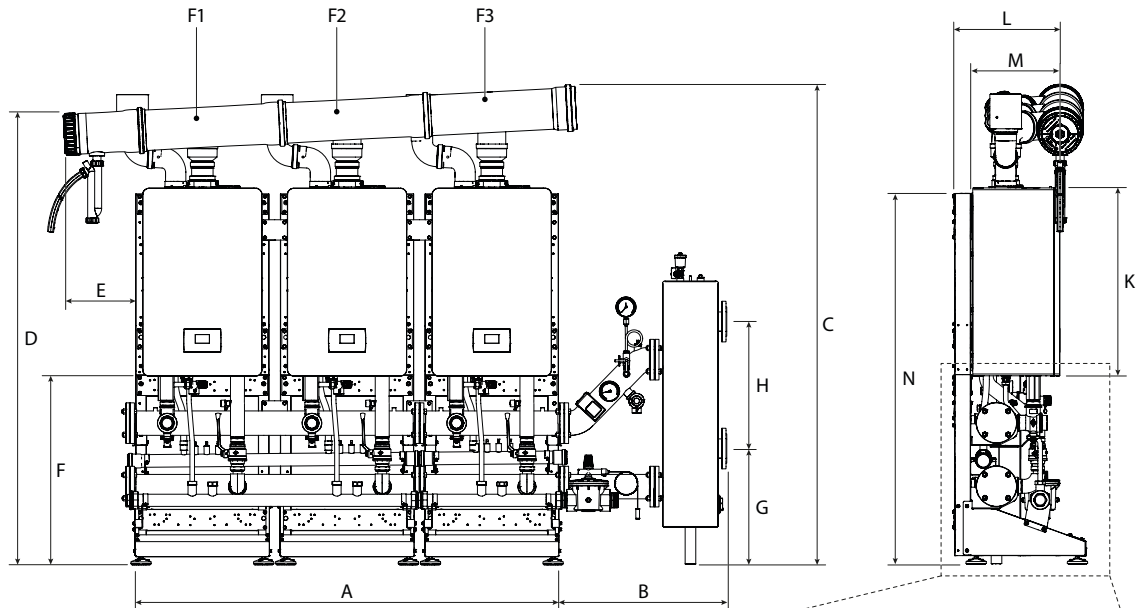

If the plate heat exchanger is present (instead of the hydraulic compensator), the reference dimensions are:

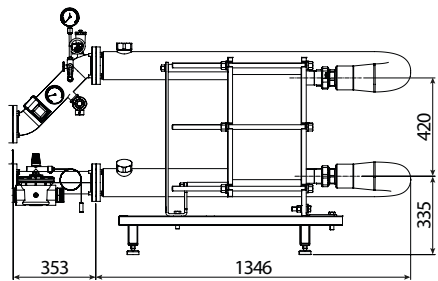

dimension B = 1,699 mm (instead of 658 mm).

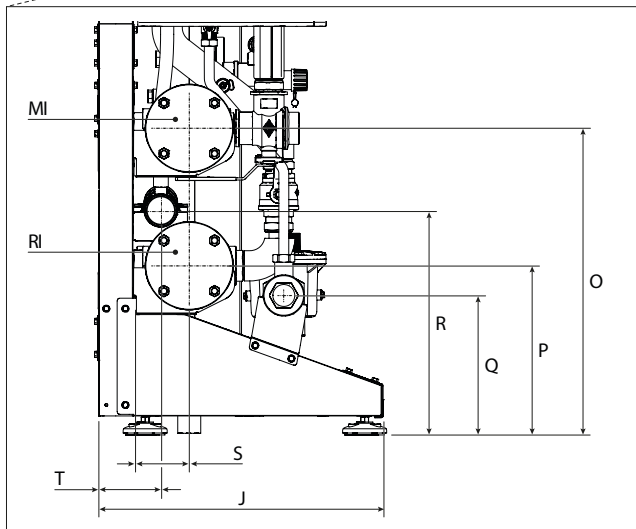

DESCRIPTION	A	B	C	D	E	F	G	H	J	K	L	M
CONDEXA HPR 35	1,670	658	1891	1777	285	743	457	500	525	740	423	351
CONDEXA HPR 45	1,670	658	1891	1777	285	743	457	500	525	740	423	351
UM	mm	mm	mm	mm	mm	mm	mm	mm	mm	mm	mm	mm

DESCRIPTION	N	O	P	Q	R	S	T	F1	F2	F3	RI*	MI*
CONDEXA HPR 35	1483	558	308	254	408	103	113	Ø160	Ø160	Ø160	Ø2"½	Ø2"½
CONDEXA HPR 45	1483	558	308	254	408	103	113	Ø160	Ø160	Ø160	Ø2"½	Ø2"½
UM	mm	mm	mm	mm	mm	mm	mm	mm	mm	mm	inch	inch

(*) Primary and secondary flange DN65 PN6 - 4 holes.

Linear cascade (FRONT) 3 modules - [55-70kW]

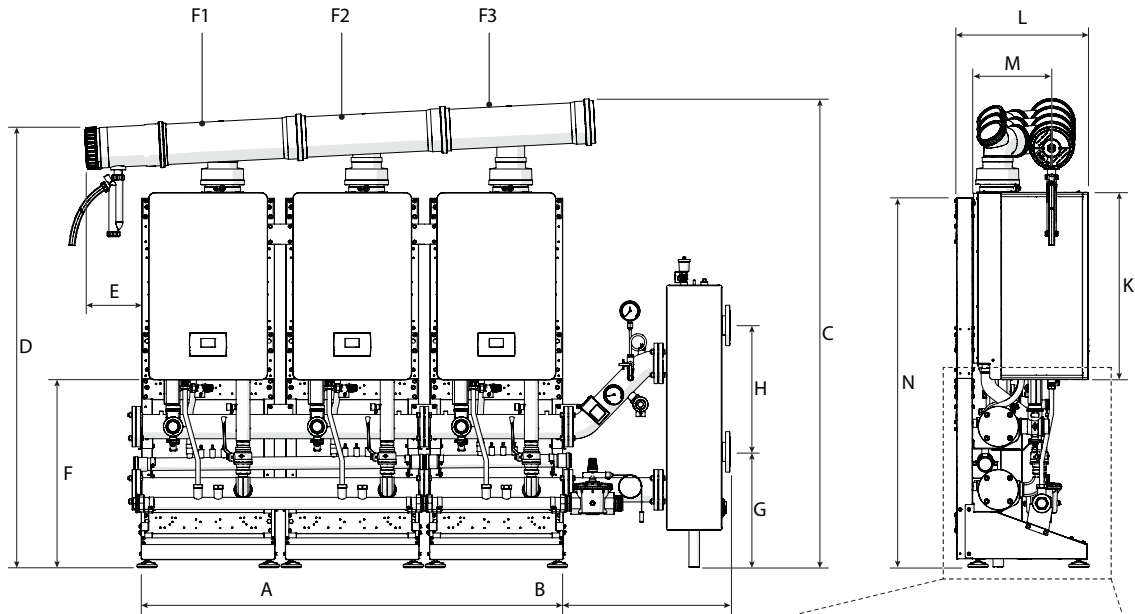

If the plate heat exchanger is present (instead of the hydraulic compensator), the reference dimensions are:

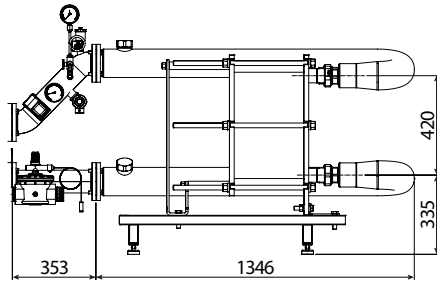

dimension B = 1,699 mm (instead of 658 mm).

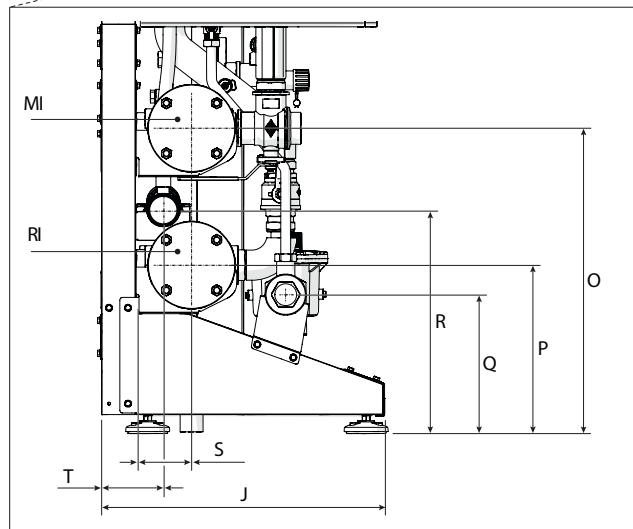

DESCRIPTION	A	B	C	D	E	F	G	H	J	K	L	M
CONDEXA HPR 55	1,670	658	1854	1740	226	743	457	500	525	740	516	312
CONDEXA HPR 70	1,670	658	1854	1740	226	743	457	500	525	740	516	312
UM	mm	mm	mm	mm	mm	mm	mm	mm	mm	mm	mm	mm

DESCRIPTION	N	O	P	Q	R	S	T	F1	F2	F3	RI*	MI*
CONDEXA HPR 55	1481	558	228	254	408	103	113	Ø160	Ø160	Ø160	Ø2"½	Ø2"½
CONDEXA HPR 70	1481	558	228	254	408	103	113	Ø160	Ø160	Ø160	Ø2"½	Ø2"½
UM	mm	mm	mm	mm	mm	mm	mm	mm	mm	mm	inch	inch

(*) Primary and secondary flange DN65 PN6 - 4 holes.

MODULAR CONDENSING BOILERS

Indoor wall-hung gas condensing modules

Linear cascade (FRONT) 4 modules - [35-45kW]

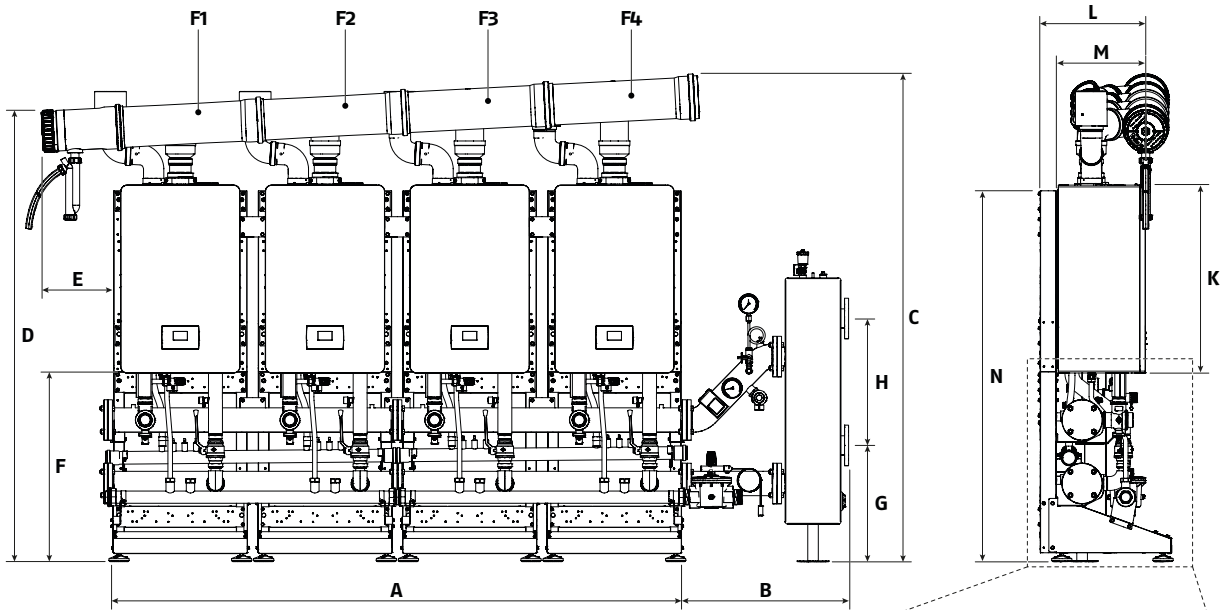

If the plate heat exchanger is present (instead of the hydraulic compensator), the reference dimensions are:

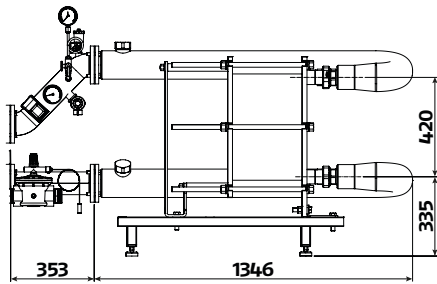

dimension B = 1,699 mm (instead of 658 mm).

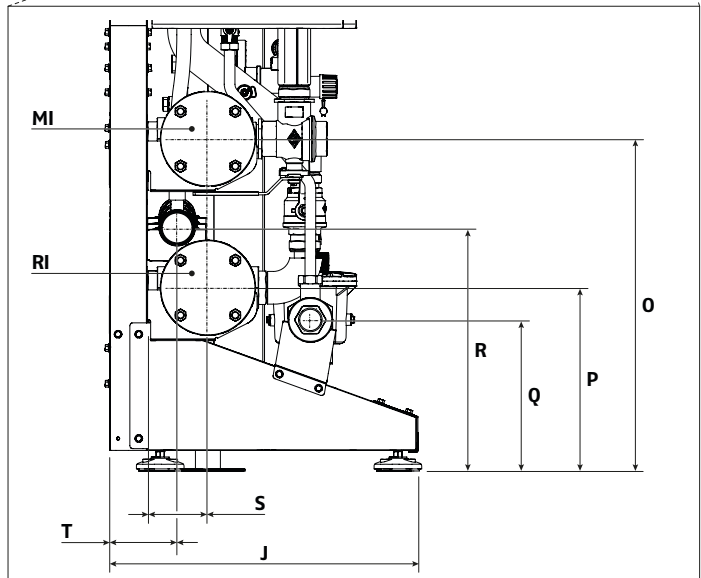

DESCRIPTION	A	B	C	D	E	F	G	H	J	K	L	M
CONDEXA HPR 35	2240	658	1921	1777	285	743	457	500	525	740	423	351
CONDEXA HPR 45	2240	658	1921	1777	285	743	457	500	525	740	423	351
UM	mm	mm	mm	mm	mm	mm	mm	mm	mm	mm	mm	mm

DESCRIPTION	N	O	P	Q	R	S	T	F1	F2	F3	F4	RI*	MI*
CONDEXA HPR 35	1483	558	308	254	408	103	113	Ø160	Ø160	Ø160	Ø160	Ø2"½	Ø2"½
CONDEXA HPR 45	1483	558	308	254	408	103	113	Ø160	Ø160	Ø160	Ø160	Ø2"½	Ø2"½
UM	mm	mm	mm	mm	mm	mm	mm	mm	mm	mm	mm	inch	inch

(*) Primary and secondary flange DN65 PN6 - 4 holes.

Linear cascade (FRONT) 4 modules - [55-70kW]

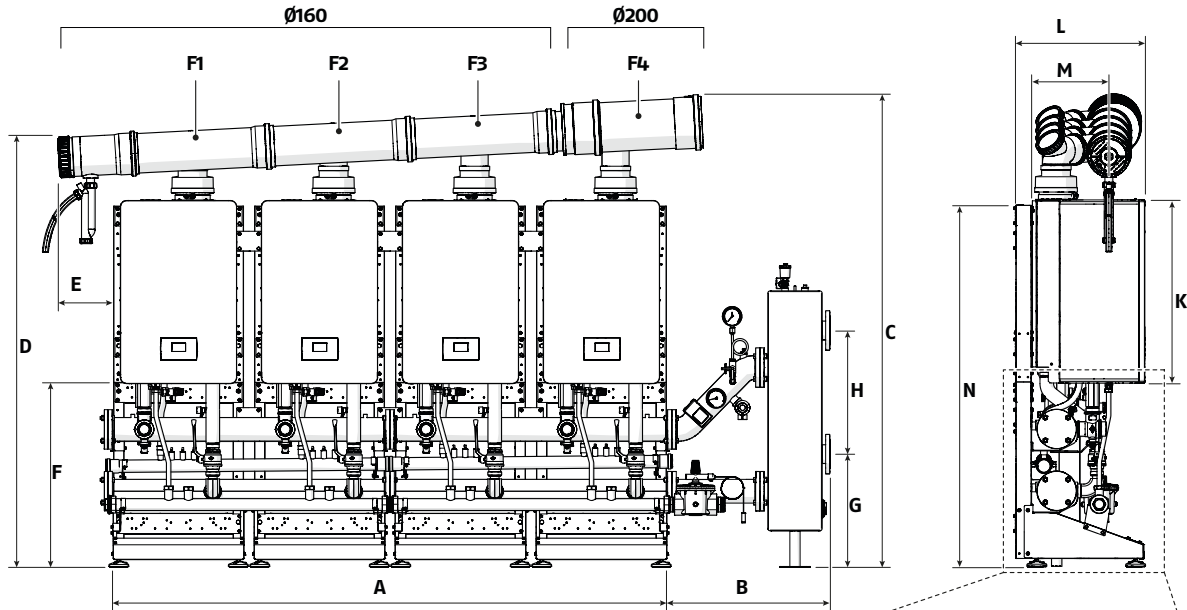

If the plate heat exchanger is present (instead of the hydraulic compensator), the reference dimensions are:

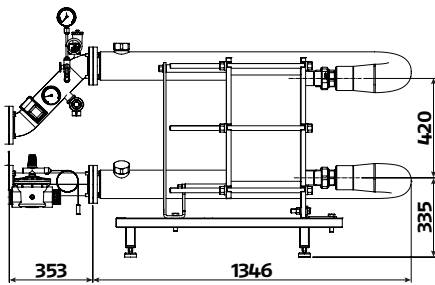

dimension B = 1,699 mm (instead of 658 mm).

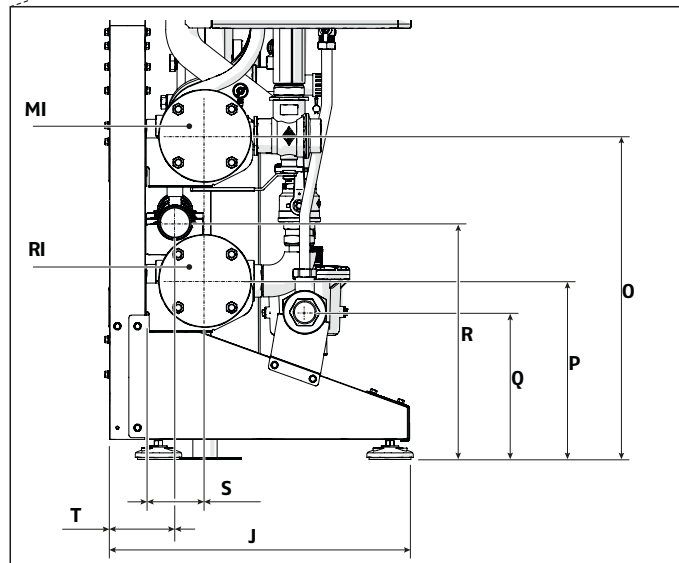

DESCRIPTION	A	B	C	D	E	F	G	H	J	K	L	M
CONDEXA HPR 55	2240	658	1892	1740	226	743	457	500	525	740	516	312
CONDEXA HPR 70	2240	658	1892	1740	226	743	457	500	525	740	516	312
UM	mm	mm	mm	mm	mm	mm	mm	mm	mm	mm	mm	mm

DESCRIPTION	N	O	P	Q	R	S	T	F1	F2	F3	F4	RI*	MI*
CONDEXA HPR 55	1481	558	228	254	408	103	113	Ø160	Ø160	Ø160	Ø200	Ø2"½	Ø2"½
CONDEXA HPR 70	1481	558	228	254	408	103	113	Ø160	Ø160	Ø160	Ø200	Ø2"½	Ø2"½
UM	mm	mm	mm	mm	mm	mm	mm	mm	mm	mm	mm	inch	inch

(*) Primary and secondary flange DN65 PN6 - 4 holes.

MODULAR CONDENSING BOILERS

Indoor wall-hung gas condensing modules

B2B cascade (BACK-TO-BACK) 2 modules - [35-45kW]

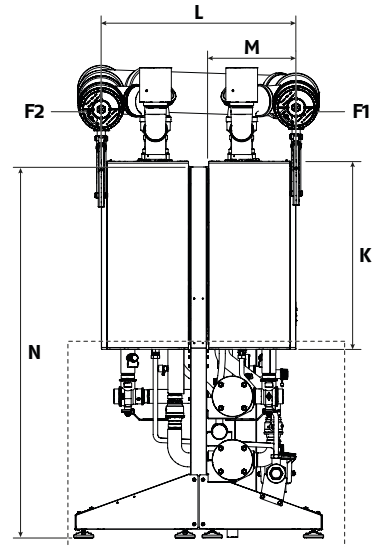
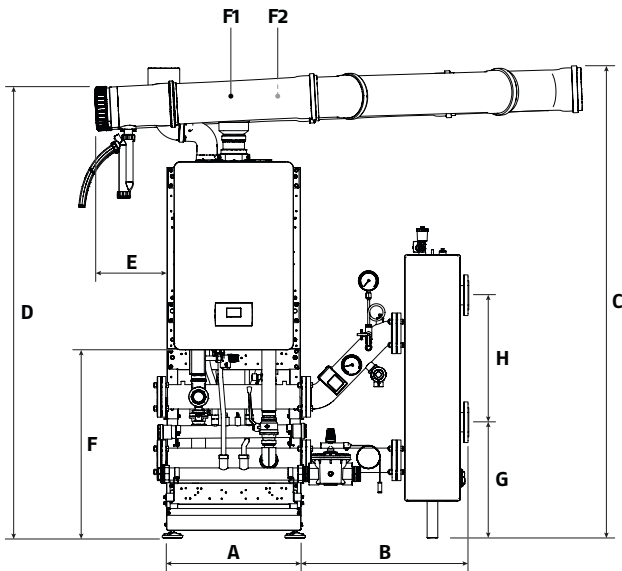

If the plate heat exchanger is present (instead of the hydraulic compensator), the reference dimensions are:

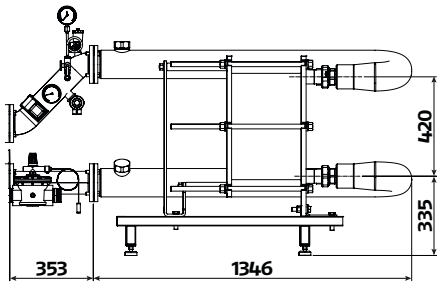

dimension B = 1,699 mm (instead of 658 mm).

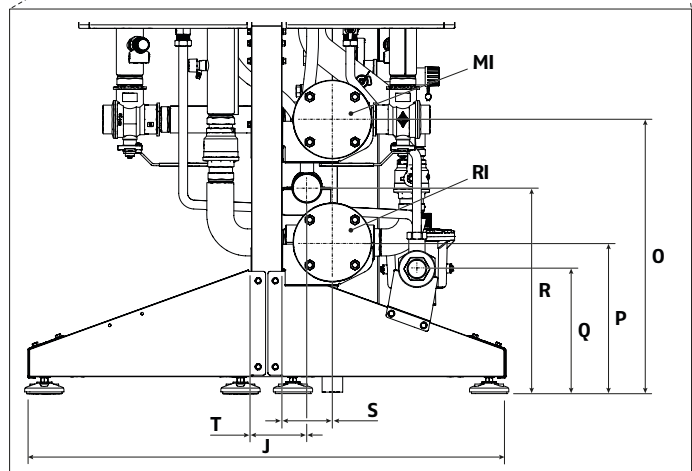

DESCRIPTION	A	B	C	D	E	F	G	H	J	K	L	M
CONDEXA HPR 35	529	658	1861	1777	285	743	457	500	972	740	764	351
CONDEXA HPR 45	529	658	1861	1777	285	743	457	500	972	740	764	351
UM	mm	mm	mm	mm	mm	mm	mm	mm	mm	mm	mm	mm

DESCRIPTION	N	O	P	Q	R	S	T	F1	F2	RI*	MI*
CONDEXA HPR 35	1483	558	308	254	408	103	113	Ø160	Ø160	Ø2"½	Ø2"½
CONDEXA HPR 45	1483	558	308	254	408	103	113	Ø160	Ø160	Ø2"½	Ø2"½
UM	mm	mm	mm	mm	mm	mm	mm	mm	mm	inch	inch

(*) Primary and secondary flange DN65 PN6 - 4 holes.

B2B cascade (BACK-TO-BACK) 2 modules - [55-70kW]

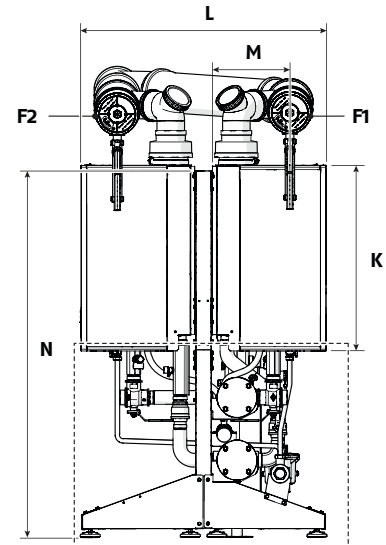
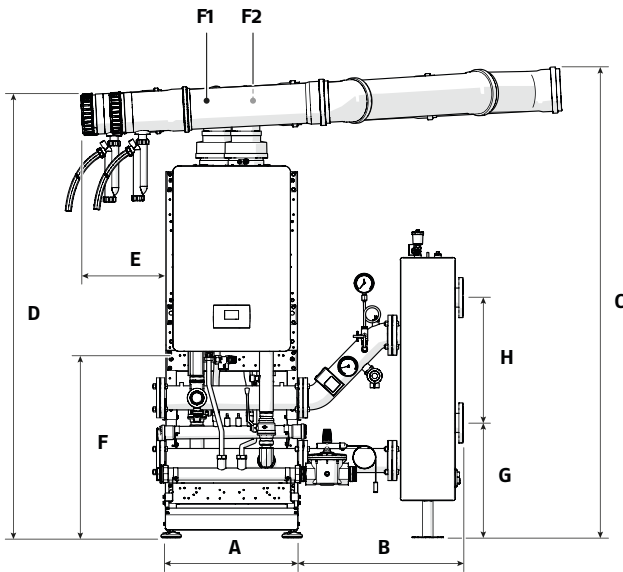

If the plate heat exchanger is present (instead of the hydraulic compensator), the reference dimensions are:

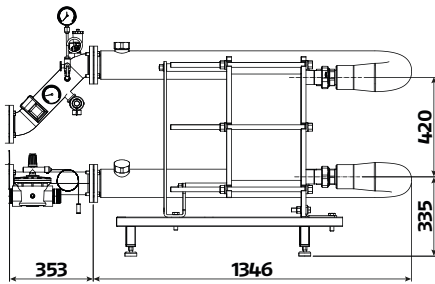

dimension B = 1,699 mm (instead of 658 mm).

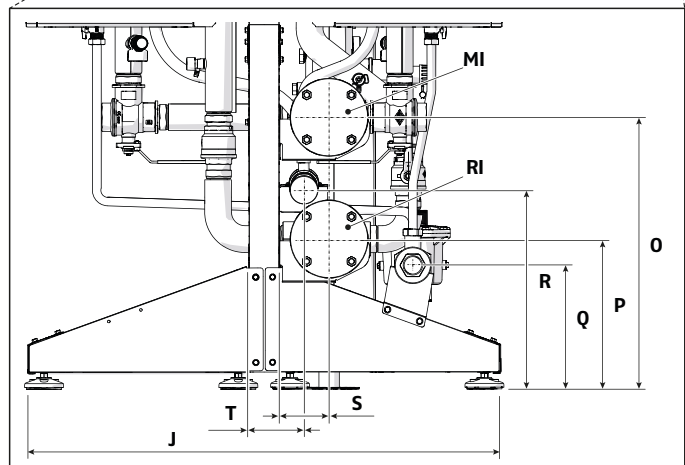

DESCRIPTION	A	B	C	D	E	F	G	H	J	K	L	M
CONDEXA HPR 55	529	658	1843	1736	338	743	457	500	972	740	982	312
CONDEXA HPR 70	529	658	1843	1736	338	743	457	500	972	740	982	312
UM	mm	mm	mm	mm	mm	mm	mm	mm	mm	mm	mm	mm

DESCRIPTION	N	O	P	Q	R	S	T	F1	F2	RI*	MI*
CONDEXA HPR 55	1481	558	228	254	408	103	113	Ø160	Ø160	Ø2"½	Ø2"½
CONDEXA HPR 70	1481	558	228	254	408	103	113	Ø160	Ø160	Ø2"½	Ø2"½
UM	mm	mm	mm	mm	mm	mm	mm	mm	mm	inch	inch

(*) Primary and secondary flange DN65 PN6 - 4 holes.

MODULAR CONDENSING BOILERS

Indoor wall-hung gas condensing modules

B2B cascade (BACK-TO-BACK) 3 and 4 modules - [35-45kW]

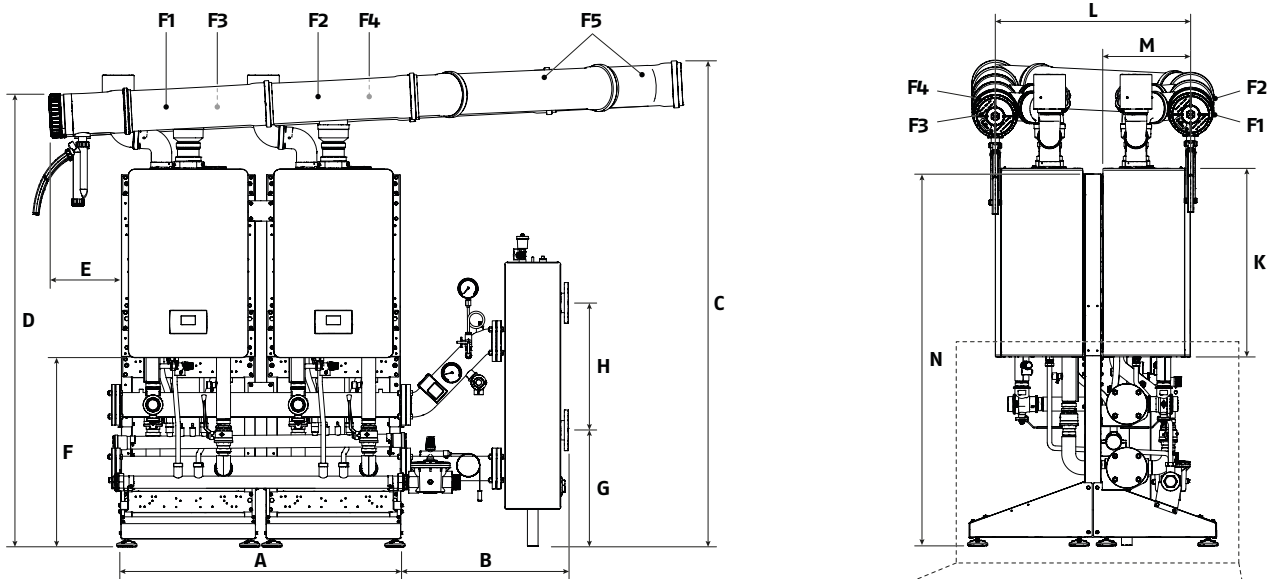

If the plate heat exchanger is present (instead of the hydraulic compensator), the reference dimensions are:

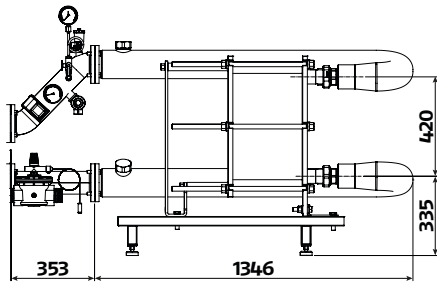

dimension B = 1,699 mm (instead of 658 mm).

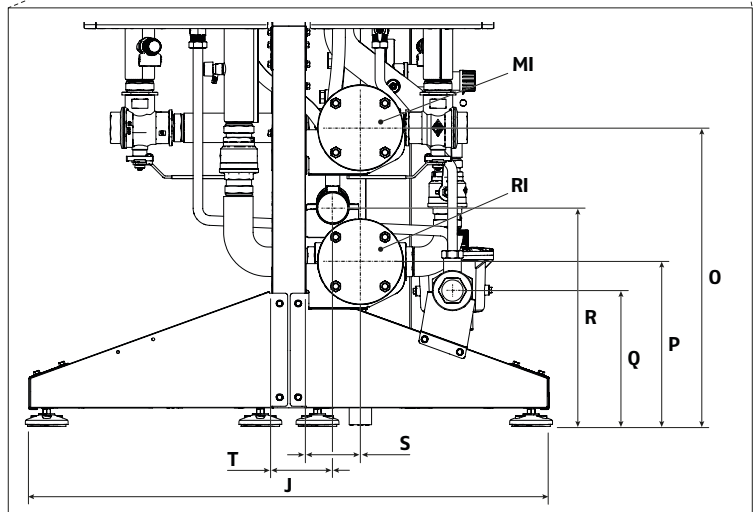

DESCRIPTION	A	B	C	D	E	F	G	H	J	K	L	M	N
CONDEXA HPR 35	1100	658	1908	1777	285	743	457	500	972	740	764	351	1483
CONDEXA HPR 45	1100	658	1908	1777	285	743	457	500	972	740	764	351	1483
UM	mm	mm	mm	mm	mm	mm	mm	mm	mm	mm	mm	mm	mm

DESCRIPTION	O	P	Q	R	S	T	F1	F2	F3	F4	F5	RI*	MI*
CONDEXA HPR 35	558	308	254	408	103	113	Ø160	Ø160	Ø160	Ø160	Ø160	Ø2"½	Ø2"½
CONDEXA HPR 45	558	308	254	408	103	113	Ø160	Ø160	Ø160	Ø160	Ø160	Ø2"½	Ø2"½
UM	mm	mm	mm	mm	mm	mm	mm	mm	mm	mm	mm	inch	inch

(*) Primary and secondary flange DN65 PN6 - 4 holes.

B2B cascade (BACK-TO-BACK) 3 and 4 modules - [55-70kW]

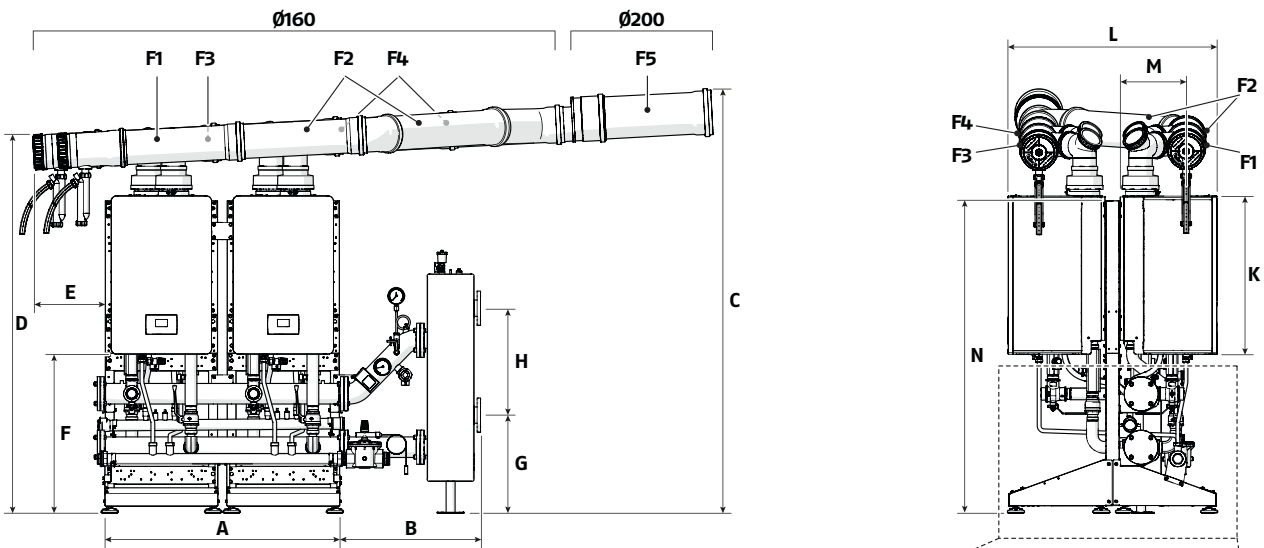

If the plate heat exchanger is present (instead of the hydraulic compensator), the reference dimensions are:

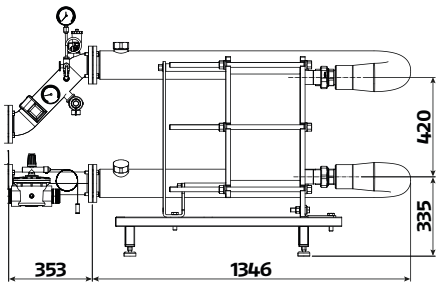

dimension B = 1,699 mm (instead of 658 mm).

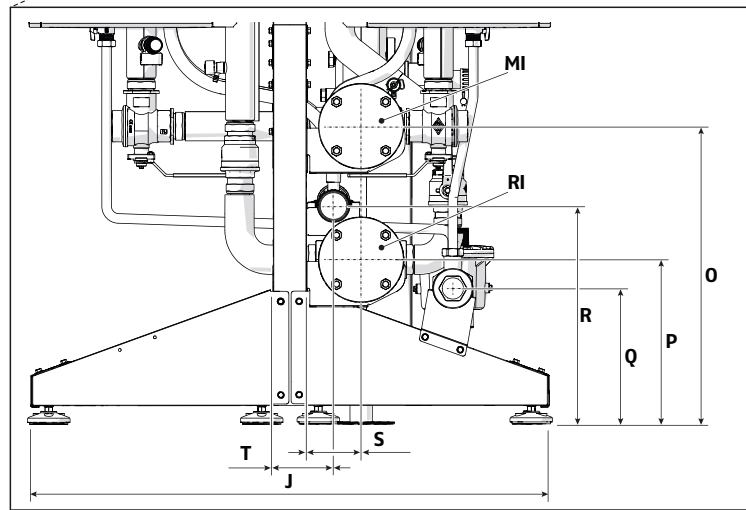

DESCRIPTION	A	B	C	D	E	F	G	H	J	K	L	M	N
CONDEXA HPR 55	1100	658	1966	1736	338	743	457	500	972	740	982	312	1481
CONDEXA HPR 70	1100	658	1966	1736	338	743	457	500	972	740	982	312	1481
UM	mm	mm	mm	mm	mm	mm	mm	mm	mm	mm	mm	mm	mm

DESCRIPTION	O	P	Q	R	S	T	F1	F2	F3	F4	F5	RI*	MI*
CONDEXA HPR 55	558	228	254	408	103	113	Ø160	Ø160	Ø160	Ø160	Ø200	Ø2"½	Ø2"½
CONDEXA HPR 70	558	228	254	408	103	113	Ø160	Ø160	Ø160	Ø160	Ø200	Ø2"½	Ø2"½
UM	mm	mm	mm	mm	mm	mm	mm	mm	mm	mm	mm	inch	inch

(*) Primary and secondary flange DN65 PN6 - 4 holes.

MODULAR CONDENSING BOILERS

Indoor wall-hung gas condensing modules

MINIMUM INSTALLATION DISTANCES

The thermal module must be installed in rooms used only for this purpose and satisfying the technical regulations and legislation in force, and where flue gas discharge and combustion air intake are channelled out of the room itself. If, on the other hand, the combustion air is picked up from the installation room, the room must have suitably sized ventilation openings complying with the technical regulations.

Space needed for in-line layout (FRONT)

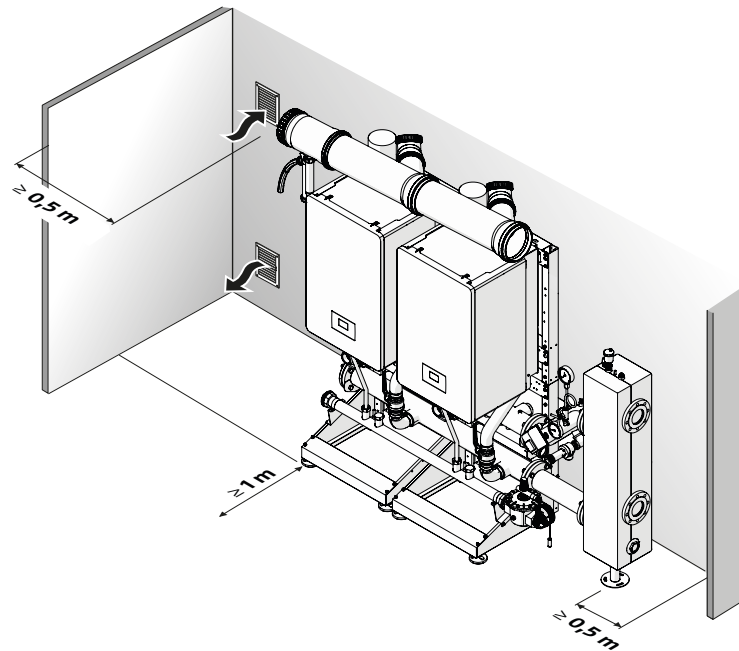

Space needed for back-to-back layout (B2B)

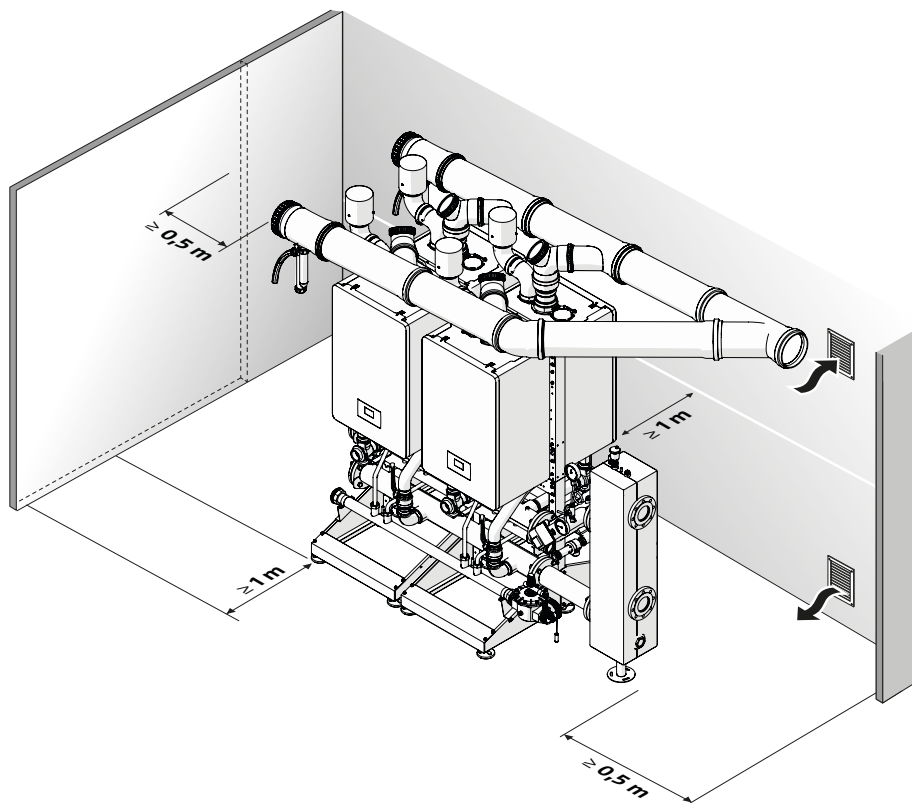

SCHEMA OF HYDRAULIC SYSTEMS

- ⚠** The DHW and heating circuits must be completed with expansion vessels of adequate capacity and suitably sized safety valves. The discharge of the safety valves and appliances must be connected to a collection and evacuation system.
- ⚠** The selection and installation of the system components is the responsibility of the installer, who must respect the standards of good practice and current legislation.
- ⚠** Special supply/make-up water must be conditioned using suitable treatment systems.
- ⚠** For the electric power connections, use H05-W-F cables with a minimum wire section of 1.5 mm², complete with terminals. For the low voltage connections, use H05-W-F cables with a section between 0.5 and 1 mm², complete with terminals.
- ⚠** When connecting the devices which are connected to the power terminal board (pumps, circulators, and also diverting/mixing valves), use interposed relays unless the maximum power absorption of all such components (including the module circulator) is less than or equal to 1.5A. The selection and sizing of these relays is the responsibility of the installer and will depend on the type of appliance connected.
- ⊘** It is forbidden to operate the thermal module and the circulators without water.

REMOTE CASCADE CONTROL

The cascade remote control (REC12) is mandatory to manage cascade configurations, together with a dedicated board (MSC) connecting the thermal modules and the REC12 itself.

It allows access to and management of all managed parameters (of the cascade, individual boiler and system).

In particular, it allows management of:

The primary circuit probe manages the cascade setpoint and is essential for managing the thermal modules as a single generator.

- up to no. 4 CONDEXA HPR in cascade (all of the same power), with settable strategy
- multi-zone systems up to no. 6 zones, direct or mixed, by adding as many dedicated kits (available as accessories), in climatic mode by connecting the external probe available as an accessory and with independent climatic curves
- an external storage cylinder for DHW production by means of a storage tank pump + storage tank probe (and consequent management of the anti-legionella function), or with storage tank thermostat
- a solar thermal system for DHW pre-heating on the cylinder.

The alternative strategies that can be set for cascade operation are:

- parallel operation of all generators with modulation according to demand (the boilers work as if they were a single unit and the same command signal is sent to all of them);
- the boilers are turned on one after the other and turned off in reverse when the set-point is reached (with rotation of the leader module and/or ignition transferred to another module in the cascade if the leader module is in fault at that time).

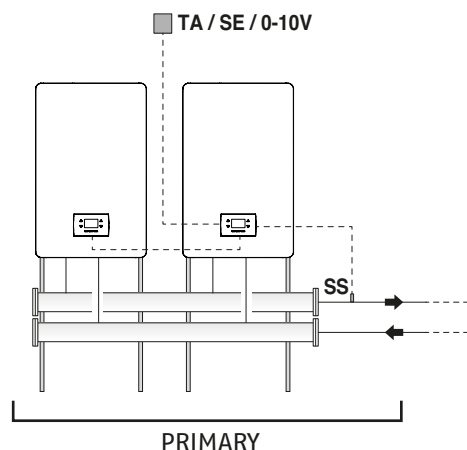

You can choose to control the cascade temperature with a probe on the primary loop, or with a secondary probe to be placed downstream of the hydraulic compensator/plate heat exchanger.

Heat demand from the plant can come:

- by room thermostat (using the TA1 input on the zone card in the case of a single-zone system; it is possible to manage up to 6 plant zones by adding as many zone cards and using the respective TA1, TA2 ... TA6 inputs);
- or by room probe (not supplied), also to be connected to the zone card
- or from analogue 0-10 voltage signal (heat request in temperature), using the dedicated input on the cascade management MSC board

or from REC12 itself (with the possibility of setting the room influence in the temperature control algorithm from a parameter) it is advisable not to exceed a length of 5 m (for the connection between REC12 and the MSC board). On the MSC board there is also a TA input (the closing of which activates a request in heating of the cascade system), to be used, for example, when the CONDEXA HPR system is controlled by a heat pump (which requires integration on the room heating system). It is possible to enable and set heating time programming for the relevant zone or for the entire system via a parameter.

MODULAR CONDENSING BOILERS

Indoor wall-hung gas condensing modules

SYSTEM CONFIGURATION FOR THE SECONDARY CIRCUIT

With the modules used in cascade form, the best results are obtained by interposing a hydraulic separator (available as an accessory) between the primary circuit (thermal modules in a cascade for heat generation) and the secondary circuit (users such as heat distribution systems for heating, DHW production system). This device compensates for different flow rates between the primary and secondary circuits.

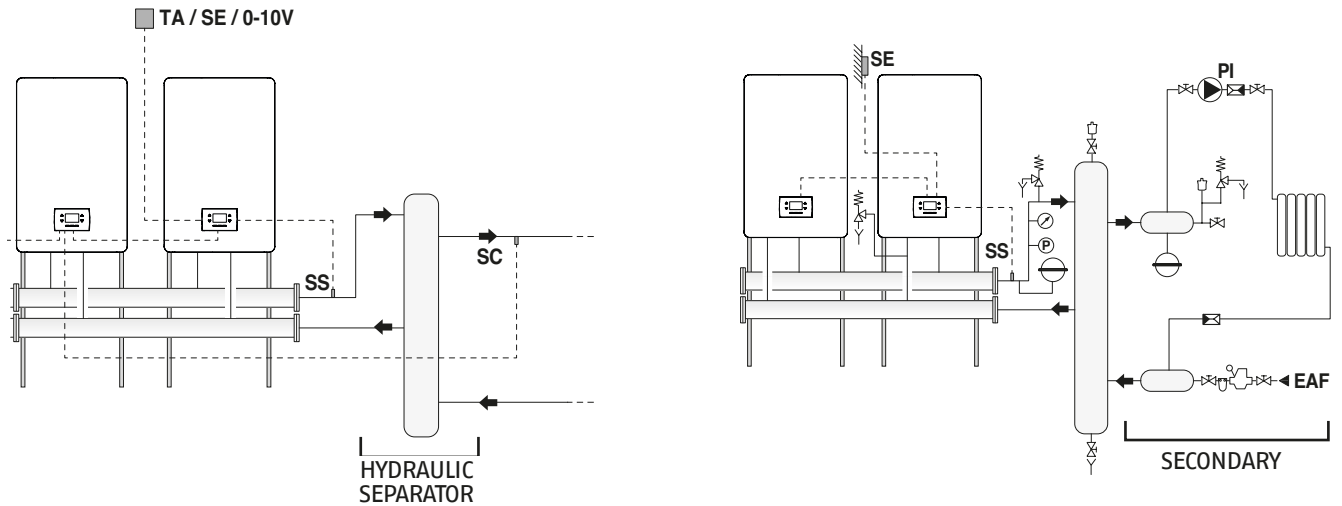

For the sake of simplicity, the hydraulic circuit downstream of the separator is intended as the secondary circuit. The standard configuration of the secondary circuit is obtained using a system circulator (PI). This circulator, connected to the cascade modules, allows thermal energy to be transferred to a user circuit such as a direct zone for high-temperature ambient heating.

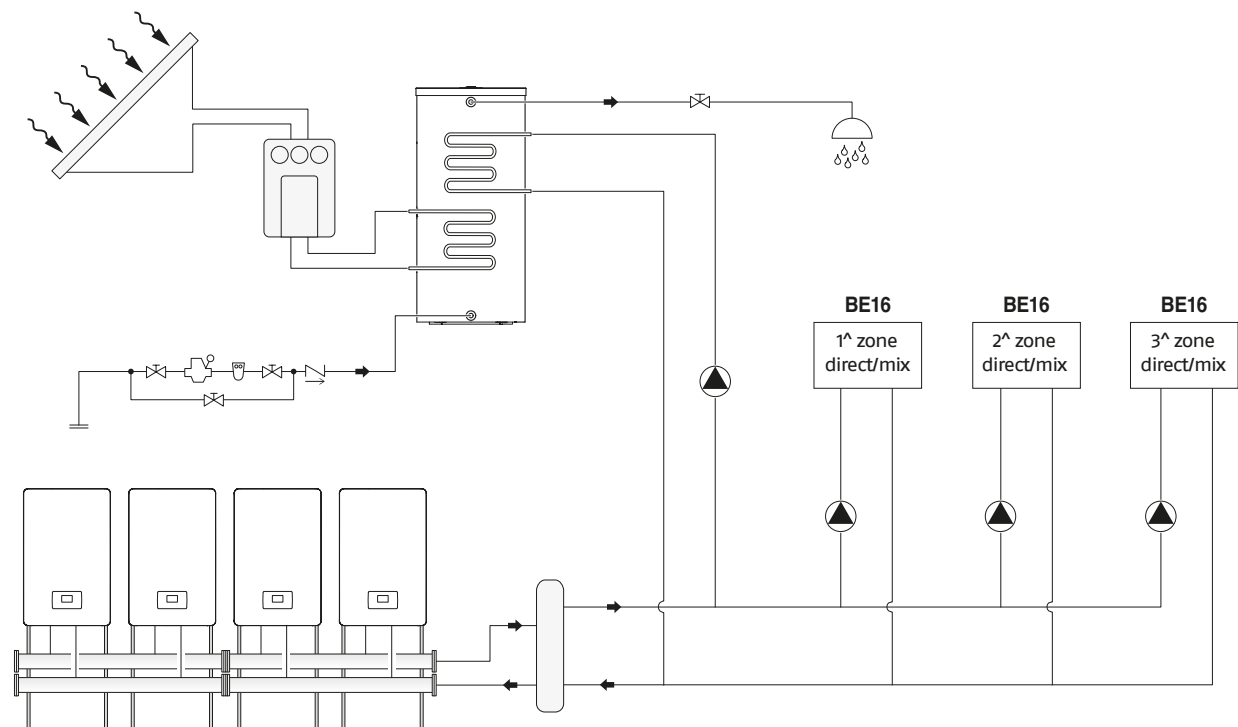

CONDEXA HPR

CONSTRUCTION DESCRIPTION FOR SPECIFICATIONS

CONDEXA HPR is a condensing, pre-mixed thermal module consisting of a modulating thermal element.

It comes in 4 models, starting from 35kW up to 70kW.

Optimum combustion control ensures high efficiency (even exceeding 108%, as calculated on the NVC) in condensation mode, and low polluting emissions - Class 6 as per UNI EN 15502.

The thermal module is designed for open chamber operation, but can be converted to sealed chamber operation by fitting the necessary flue pipe.

In standard configuration, the appliance has an IPX5D protection level with indoor installation or outdoor installation in a partially protected place.

CONDEXA HPR appliances can be connected in cascade format to obtain a maximum output of 280 kW.

The electronics of the CONDEXA HPR generator can be expanded with the aid of specific kits, to control hybrid or thermal solar systems.

The main technical characteristics of the appliance are:

- Pre-mix burner with constant air-gas ratio and twin electrode, firing and flame detection.
- Single-stage heat exchanger in AISI 441 stainless steel, designed to maximise the heat exchange surface and guarantee optimum corrosion resistance.
- Module output 35÷70 kW, with possible cascades of modules of the same output.
- Maximum flue gas output temperature 100°C.
- Microprocessor-operated management and control with self-diagnostics shown on a display, and the logging of the main errors.
- Anti-freeze function.
- Outdoor temperature probe that enables the climatic control function (accessory).
- Designed to take an ambient thermostat / heat request for the low and high temperature zones.
- Each stand-alone generator can manage a direct heating circuit and a DHW circuit with an external storage tank; the electronics can be expanded to cover up to three direct or mixed zones on the secondary circuit and the solar thermal system.
- In cascade configuration, it can manage up to six direct or mixed zones on the secondary circuit.
- High-efficiency modulating circulator as standard, with high residual head (modulation on the system side only, proportional to the power delivered by the boiler; in DHW mode, the circulator works at the maximum speed).
- For output levels greater than 35 kW, there are safety accessories and devices complete with certification.
- Configurations in cascade format for up to 4 generators, both FRONT and BACK-TO-BACK, complete with all the hydraulic and electric accessories and flue pipes.
- For both the stand-alone and cascade versions, hydraulic separators and plate heat exchangers are available as optional accessories for the interface with the systems.

SAFETY DEVICES

All appliance functions are electronically controlled by a dual processor technology board approved for safety functions. Any malfunction results in the appliance being shut down and the automatic closure of the gas valve.

The following are installed on the water circuit:

- Safety thermostat 102±3°C
- Pressure transducer with minimum pressure (0,8 bar) control function
- Differential pressure switch for continuous minimum flow rate control on the primary circuit
- Temperature probes on delivery and return that continually measure the temperature difference between input and output fluids and enable activation of the control

The following are installed on the combustion circuit:

- Gas solenoid valve with pneumatic gas flow rate compensation according to the intake air flow rate
- Two separate electrodes, one for firing and the other for detection
- Flue gas temperature probe
- Non-return valve (check valve) for the connection of the generator with collective chimneys under positive pressure

FUNCTIONS:

- Setting of the date and time
- Setting of the heating system in 4 modes:
 - Operation with ambient thermostat / heat request and fixed setpoint
 - Operation with ambient thermostat / heat request and variable setpoint depending on the outdoor temperature
 - Operation with OT+ input with heat request, and fixed setpoint
 - Operation with OT+ input with heat request, and variable setpoint depending on the outdoor temperature
- Setting of DHW production in 3 modes:
 - No DHW production
 - DHW production with storage tank, controlled by a storage tank probe
 - DHW production with storage tank, controlled by a thermostat
- Anti-legionella function
- Timed program: seasonal, holiday, groups of similar zones

MODULAR CONDENSING BOILERS

Indoor wall-hung gas condensing modules

- The screen shows:
 - Delivery temperature
 - Return temperature
 - DHW temperature (the sensor must be connected in order to display the real value, otherwise the default value is shown)
 - Outdoor temperature
 - Flue gas temperature
 - System temperature (the sensor must be connected in order to display the real value, otherwise the default value is shown)
 - Fan speed
 - Ionisation
 - Status
 - Error

MATERIAL INCLUDED

- Documents:
 - Instruction booklet
 - Hydraulic test certificate
 - Energy label
- Other material supplied:
 - Wall-mounting bracket with plugs (4 plugs $\varnothing=10$ mm, suitable for concrete, brick, compact stone and perforated concrete block walls)

CONFORMITY

CONDEXA HPR boilers comply with:

- Regulation (EU) 2016/426
- Efficiency Directive 92/42/EEC and Attachment E of the Pres. Decree 26 August 1993 no. 412
- Electromagnetic Compatibility Directive 2014/30/EU
- Low Voltage Directive 2014/35/EU
- Ecodesign Requirements for Energy-Related Products Directive 2009/125/EC
- Regulation (EU) 2017/1369 Energy Labelling
- Delegated Regulation (EU) No. 811/2013
- Delegated Regulation (EU) No. 813/2013
- Boiler standards for gas heating – General requisites and EN 15502-1 tests
- Specific regulations for type C appliances and type B2, B3 and B5 appliances with a rated heat output no larger than 1000 kW EN 15502-2/1
- SSIGA Gas Appliance Directive G1
- AICAA Fire prevention requirements
- CFST LPG Directive Part 2
- VARIOUS cantonal and communal provisions on air quality and energy saving.

RIELLO

RIELLO S.p.A. -
37045 Legnago (VR) Italy
tel. +39 0442 630111

www.riello.com



The company is constantly working to perfect the features of its entire production range so the design and size, technical data, equipment and accessories may be subject to change.



©2024 Carrier. All Rights Reserved.
All trademarks and service marks referred herein
are property of their respective owners.