

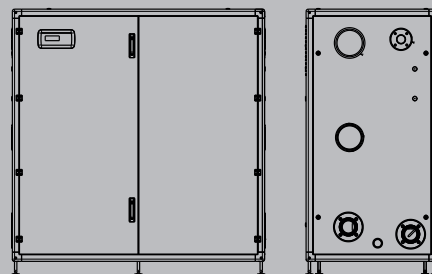

## Steel Pro Power

Indoor/Outdoor floor standing gas condensing modules

Compliant with the Regulation 2009/125/CE  
Modular thermal condensing units for indoor  
use (for outdoor with optional kit) composed  
of apparatus cabinet, thermal modules  
from 57 kW up to 131 kW and installation  
accessories.  
Low emission, NOx class 6 (UNI EN 15502)



# Steel Pro Power

## PRODUCT OVERVIEW

Steel Pro Power is the new Riello condensing modular system, specifically designed and developed to reach very high energy energetic efficiency values, while minimising the occupied space.

The system, ready for a simple and quick installation, consists of apparatus cabinets designed according to the modularity principles, consisting of an assembled anodised aluminium frame and painted panels.

The standard product is suitable for indoor installation, with open chamber combustion; it can be converted to sealed combustion or to a version for outdoor installation by fitting specific accessory kits.

The cabinets are equipped with 2, 3 or 4 heating elements of 57 to 131 kW, with a total power from 114 to 524 kW.

Each thermal module are equipped with a low consumption water flow modulating pumps, with constant  $\Delta T$  regulation in order to maximize condensation and efficiency.

The standard supply also includes management and control electronic adjustment, hydraulic delivery and return manifolds, gas, flue gas and condensate drain manifolds.

The heat exchangers, with patented geometries, consist of two plain concentric stainless steel tubes, with a pentagonal section inside and circular section outside; they have been specifically designed to maximize the exchange surface, offer maximum corrosion resistance and minimum pressure drops. These characteristics allow operation with high  $\Delta T$ , allowing the reduction of the times needed to reach the system steady state.

The models with 131 kW heat exchanger (270-405-540) are designed for cascade installation, with side by side coupling, up to a total maximum number of 10 units and a power of 1310 kW.

The control electronics, compatible with the MOD-BUS protocol, allows the climatic regulation with cascade management of the thermal modules, the automatic summer / winter switching, the possibility of remote management by means of 0..10V input and alarm output signal.

The control system manages the heat distribution on the secondary circuit, controlling: a direct zone, one or more mixed zones (from 1 to 3, depending on the model) and the storage cylinder circuit.

Through specific accessories, there is also the possibility to manage additional mixed zones (up to max. 16).

The optimal combustion management and the high modulation ratios (up to 1:50) allow high yields and low pollutant emissions (Class 6 according to UNI EN 15502).

Continuity of service is guaranteed by system modularity: even in the event of fault of a module, overall operation will not be compromised. Accessories designed to guarantee a simple, rapid and complete installation of the thermal power station are also available.

Maximum operating pressure 6 bar.

## TECHNICAL DATA 114-2 P - 270-2 P

STEEL PRO POWER MODELS	U.M.	114-2 P		140-2 P		180-2 P		230-2 P		270-2 P	
		G20	G31	G20	G31	G20	G31	G20	G31	G20	G31
<b>APPLIANCE TYPE</b>											
Type		Condensing heating B23, B53; B53P									
Fuel		G20-G25-G30-G31									
Combustion chamber		Vertical									
Flue gases discharge type-approval		B23, B23P, B53P, C13(*), C33(*), C53(*), C63(*)									
Appliance category according to UNI 10642		II2H3P									
<b>OUTPUTS AND EFFICIENCY</b>											
Rated heat input NCV	kW	114,00		136,00		180,00		223,20		262,00	
Rated heat input GCV	kW	126,0		152,0		200,0		248,0		292,0	
Nominal heat output max. 80-60°C	kW	111,4		134,0		176,6		219,6		258,0	
Nominal heat output max. 60-40°C	kW	119,2		142,8		187,6		232,4		274,6	
Nominal heat output max. 50-30°C	kW	123,8		147,8		194,8		242,2		284,2	
Minimum heat input NCV	kW	13,7		13,7		19,4		22,4		26,3	
Minimum heat input GCV	kW	15,0		15,0		21,6		24,9		29,0	
Minimum heat output 80-60°C	kW	13,5		13,5		19,2		22,1		26,0	
Minimum heat output 50-30°C	kW	14,9		14,9		21,1		24,5		28,9	
Useful efficiency at nominal heat output 80-60°C (NCV)	%	97,72		98,53		98,11		98,40		98,47	
Useful efficiency at minimum heat output 80-60°C (NCV)	%	98,90		98,90		98,80		99,20		99,10	
Useful efficiency at nominal heat output 50-30°C (NCV)	%	108,60		108,10		108,30		108,60		108,30	
Useful efficiency at minimum heat output 50-30°C (NCV)	%	109,30		109,30		109,20		110,00		110,00	
Useful efficiency 30% 50-30°C GCV (NCV)	%	98,94 (109,36)		97,81 (109,31)		98,00 (108,89)		98,39 (108,93)		98,17 (109,41)	
Combustion efficiency	%	99,0		99,3		99,3		99,3		99,3	
Chimney losses with the burner off	%	0,10		0,10		0,10		0,10		0,10	
Chimney losses with the burner on P. max 80-60°C	%	2,30		2,30		2,50		2,50		2,60	
Chimney losses with the burner on at 30% Pn 50-30°C	%	0,50		0,50		0,60		0,50		0,60	
Chimney losses with the burner on P. min 80-60°C	%	0,12		0,11		0,22		0,10		0,10	
Heat losses at the appliance casing with average temperature of 70°C and burner on	%	0,50		0,50		0,50		0,50		0,50	
Heat losses at the appliance casing with average temperature of 70°C and burner off	%	0,50		0,50		0,50		0,50		0,50	
Flue gas temperature at max. power and min. power 80-60°C	°C	71 - 61		72 - 61		76 - 62		75 - 61		77 - 61	
Flue gas temperature at max. power and min. power 50-30°C	°C	45 - 33		46 - 33		47 - 35		45 - 33		48 - 35	
Air index λ at max. power	no.	1,27	1,29	1,27	1,29	1,27	1,29	1,27	1,29	1,27	1,29
Air index λ at min. power	no.	1,27	1,29	1,27	1,29	1,27	1,29	1,27	1,29	1,27	1,29
Mass flue gas flow rate at max-min output	g/s	53 - 6	51 - 6	64 - 6	62 - 6	84 - 9	82 - 9	104 - 10	101 - 10	122 - 12	119 - 12
Flue gases residual discharge head at min. power	Pa	35,00		35,00		32,00		30,00		28,00	
Flue gases residual discharge head at max. power	Pa	510,00		630,00		560,00		500,00		353,00	
<b>ELECTRICAL DATA</b>											
Voltage supply	V - Hz	230-50									
Electrical protection level	IP	IPX4D									
Electric power consumption with the boiler at max. power	W	198		264		460		706		964	
Electric power consumption with the boiler at min. power	W	92		96		126		198		220	
Pumps electric power consumption at max. power	W	100		110		160		296		360	
Pumps electric power consumption at min. power	W	40		44		64		118		144	
<b>HEATING OPERATION</b>											
Water temperature selection range (with plate heat exchanger)	°C	20-80/(85)*									
Lockout thermostat activation temperature	°C	95									
Maximum operating temperature	°C	100									
Maximum operating pressure	bar	6									
Minimum operating pressure	bar	0,7									
Water content	l	45,00		45,00		50,00		60,00		75,00	
Residual discharge head water side with ΔT 20°C	mbar	400		280		450		300		500	
Maximum condensation production at maximum output 50-30°C	l/h	17,80		20,20		27,20		35,00		39,60	
Noise levels (sound power)	dB(A)	56		58		58		60		61	
<b>GAS FEEDING DATA</b>											
Gas feeding maximum pressure	mbar	60	60	60	60	60	60	60	60	60	60
Gas feeding nominal pressure	mbar	20	37	20	37	20	37	20	37	20	37
Gas feeding minimum gas pressure	mbar	17	25	17	25	17	25	17	25	17	25
<b>SIZE DATA</b>											
Heating delivery diameter	∅ DN	3" DN80 PN6		3" DN80 PN6		3" DN80 PN6		3" DN80 PN6		5" DN125 PN6	
Heating return diameter	∅ DN	3" DN80 PN6		3" DN80 PN6		3" DN80 PN6		3" DN80 PN6		5" DN125 PN6	
Gas input diameter	∅ DN	2" DN50 PN6		2" DN50 PN6		2" DN50 PN6		2" DN50 PN6		3" DN80 PN6	
Condensate drain diameter	∅ mm	50		50		50		50		50	
Casing height	mm	1800		1800		1800		1800		1800	
Casing width	mm	900		900		900		900		900	
Casing depth	mm	890		890		890		890		890	
Flue gases exhaust diameter	∅ mm	DN160		DN160		DN160		DN160		DN300	
Air suction diameter (optional)	∅ mm	DN160		DN160		DN160		DN160		DN300/DN160	
Empty weight	kg	270		270		280		300		350	

(\*) Configurations possible only with the installation of dedicated accessories (available separately).

(\*\*) Weights calculated according to standard EN 15502.

(\*\*\*) Values referred to atmospheric pressure at sea level.

# CONDENSING GENERATORS

Indoor/Outdoor floor standing gas condensing modules

## TECHNICAL DATA 300-3 P - 540-4 P

	STEEL PRO POWER MODELS	U.M.	300-3 P		345-3 P		405-3 P		460-4 P		540-4 P	
			G20	G31	G20	G31	G20	G31	G20	G31	G20	G31
<b>APPLIANCE TYPE</b>												
Type	Condensing heating B23, B53; B53P											
Fuel	G20-G25-G30-G31											
Combustion chamber	Vertical											
Flue gases discharge type-approval	B23, B23P, B53P, C13(*), C33(*), C53(*), C63(*)											
Appliance category according to UNI 10642	II2H3P											
<b>OUTPUTS AND EFFICIENCY</b>												
Rated heat input NCV	kW	291,00		336,00		393,00		446,40		524,00		
Rated heat input GCV	kW	324,0		372,0		438,0		496,0		584,0		
Nominal heat output max. 80-60°C	kW	285,9		329,4		387,0		439,2		516,0		
Nominal heat output max. 60-40°C	kW	303,3		348,6		411,9		464,8		549,2		
Nominal heat output max. 50-30°C	kW	315,3		363,6		426,3		484,4		568,4		
Minimum heat input NCV	kW	19,4		22,4		26,3		22,4		26,3		
Minimum heat input GCV	kW	21,6		24,9		29,0		24,9		29,0		
Minimum heat output 80-60°C	kW	19,2		22,1		26,0		22,1		26,0		
Minimum heat output 50-30°C	kW	21,1		24,5		28,9		24,5		28,9		
Useful efficiency at nominal heat output 80-60°C (NCV)	%	98,25		98,4		98,47		98,40		98,47		
Useful efficiency at minimum heat output 80-60°C (NCV)	%	98,80		99,20		99,10		99,20		99,10		
Useful efficiency at nominal heat output 50-30°C (NCV)	%	108,20		108,60		108,30		108,60		108,30		
Useful efficiency at minimum heat output 50-30°C (NCV)	%	109,20		110,00		110,00		110,00		110,00		
Useful efficiency 30% 50-30°C GCV (NCV)	%	97,84 (108,93)		98,39 (108,93)		98,17 (109,41)		98,39 (108,93)		98,17 (109,41)		
Combustion efficiency	%	99,0		99,0		99,0		99,3		99,3		
Chimney losses with the burner off	%	0,10		0,10		0,10		0,10		0,10		
Chimney losses with the burner on P. max 80-60°C	%	2,60		2,50		2,60		2,50		2,60		
Chimney losses with the burner on at 30% Pn 50-30°C	%	0,60		0,50		0,60		0,50		0,60		
Chimney losses with the burner on P. min 80-60°C	%	0,20		0,10		0,10		0,10		0,10		
Heat losses at the appliance casing with average temperature of 70°C and burner on	%	0,33		0,33		0,33		0,25		0,25		
Heat losses at the appliance casing with average temperature of 70°C and burner off	%	0,33		0,33		0,33		0,25		0,25		
Flue gas temperature at max. power and min. power 80-60°C	°C	78 - 62		75 - 61		77 - 61		75 - 61		77 - 61		
Flue gas temperature at max. power and min. power 50-30°C	°C	49 - 35		45 - 33		48 - 35		45 - 33		48 - 35		
Air index λ at max. power	no.	1,27	1,29	1,27	1,29	1,27	1,29	1,27	1,29	1,27	1,29	
Air index λ at min. power	no.	1,27	1,29	1,27	1,29	1,27	1,29	1,27	1,29	1,27	1,29	
Mass flue gas flow rate at max-min output	g/s	136 - 9	132 - 9	156 - 10	152-10	183-12	179-12	208-10	203-10	245-12	238-12	
Flue gases residual discharge head at min. power	Pa	32,00		30,00		28,00		30,00		28,00		
Flue gases residual discharge head at max. power	Pa	610,00		500,00		353,00		500,00		353,00		
<b>ELECTRICAL DATA</b>												
Voltage supply	V - Hz	230-50										
Electrical protection level	IP	IPX4D										
Electric power consumption with the boiler at max. power	W	951		1059		1446		1412		1928		
Electric power consumption with the boiler at min. power	W	228		297		330		396		440		
Pumps electric power consumption at max. power	W	342		444		540		592		720		
Pumps electric power consumption at min. power	W	135		177		216		236		288		
<b>HEATING OPERATION</b>												
Water temperature selection range (with plate heat exchanger)	°C	20-80/(85)*										
Lockout thermostat activation temperature	°C	95										
Maximum operating temperature	°C	100										
Maximum operating pressure	bar	6										
Minimum operating pressure	bar	0,7										
Water content	l	80,00		100,00		120,00		120,00		150,00		
Residual discharge head water side with ΔT 20°C	mbar	300		300		500		300		500		
Maximum condensation production at maximum output 50-30°C	l/h	45,00		52,50		59,40		70,00		79,20		
Noise levels (sound power)	dB(A)	60		61		62		63		64		
<b>GAS FEEDING DATA</b>												
Gas feeding maximum pressure	mbar	60	60	60	60	60	60	60	60	60	60	60
Gas feeding nominal pressure	mbar	20	37	20	37	20	37	20	37	20	37	20
Gas feeding minimum gas pressure	mbar	17	25	17	25	17	25	17	25	17	25	17
<b>SIZE DATA</b>												
Heating delivery diameter	∅ DN	3" DN80 PN6		3" DN80 PN6		5" DN125		3" DN80 PN6		5" DN125		
Heating return diameter	∅ DN	3" DN80 PN6		3" DN80 PN6		5" DN125		3" DN80 PN6		5" DN125		
Gas input diameter	∅ DN	2" DN50 PN6		2" DN50 PN6		3" DN80 PN6		2" DN50 PN6		3" DN80 PN6		
Condensate drain diameter	∅ mm	50		50		50		50		50		
Casing height	mm	1800		1800		1800		1800		1800		
Casing width	mm	1700		1700		1700		1700		1700		
Casing depth	mm	890		890		890		890		890		
Flue gases exhaust diameter	∅ mm	DN160		DN160		DN300/DN160		DN160		DN300		
Air suction diameter (optional)	∅ mm	DN160		DN160		DN300		DN160		DN300		
Empty weight	kg	450		490		540		560		600		

(\*) Configurations possible only with the installation of dedicated accessories (available separately).

4 (\*\*) Weights calculated according to standard EN 15502.

(\*\*\*) Values referred to atmospheric pressure at sea level.

## ERP DATA 114-2 P - 270-2 P

STEEL PRO POWER MODELS	U.M.	114-2 P		140-2 P		180-2 P		230-2 P		270-2 P		
		G20	G31	G20	G31	G20	G31	G20	G31	G20	G31	
Seasonal ambient heating energy efficiency class		-	-	-	-	-	-	-	-	-	-	
Nominal output	kW	114,0		136,0		180,0		224,0		262,0		
Seasonal ambient heating energy efficiency $\eta_s$	%	94		93		93		93		93		
<b>EFFECTIVE HEAT OUTPUT</b>												
At nominal heat output and in high temperature mode P4	kW	114,0	-	134,0	-	176,6	-	219,6	-	258,0	-	
At 30% of nominal heat output and in low temperature mode P1	kW	37,4	-	44,6	-	58,8	-	73,2	-	86,6	-	
<b>EFFICIENCY</b>												
At nominal heat output and in high temperature mode $\eta_4$ (GCV)	%	88,41		88,16		88,30		88,55		88,36		
At 30% of nominal heat output and in low temperature mode $\eta_1$ (GCV)	%	98,94		97,81		98,00		98,39		98,17		
<b>AUXILIARIES ELECTRICITY CONSUMPTION</b>												
With full load Elmax	W	198		264		460		706		964		
With partial load Elmin	W	92		96		126		198		220		
In standby mode PSB	W	26		26		12		12		16		
<b>OTHER PARAMETERS</b>												
Heat losses in Pstby standby mode	W	159,16		194,47		255,56		316,64		374,47		
Energy consumption of the Pign pilot flame	W	-		-		-		-		-		
Annual energy consumption QHE	GJ	236,0		282,0		364,0		384,0		532,0		
Sound power level indoors LWA	dB(A)	56,00		58,00		58,00		60,00		61,00		
Nitrogen oxide emissions Nox (**)	mg/kWh	34,20		36,40		38,10		39,30		46,10		
NOx class	n°	6		6		6		6		6		
Emission values at maximum and minimum output (**)		G20	G31	G20	G31	G20	G31	G20	G31	G20	G31	
Maximum	p.p.m.	CO s.a. lower than	79,0	142,0	90,0	147,0	81,0	153,0	89,0	177,0	91,5	185
	%	CO <sub>2</sub> (***)	9,0	10,4	9,0	10,4	9,0	10,4	9,0	10,4	9,0	10,4
	p.p.m.	NOx s.a. lower than	30,0	40,0	30,0	40,0	30,0	40,0	30,0	40,0	30,0	40,0
	°C	T flue gases	71,0		72,0		76,0		75,0		77,0	
Minimum	p.p.m.	CO s.a. lower than	6,5	11,0	6,5	11,0	7,5	12,0	4,6	14,0	5,6	16,0
	%	CO <sub>2</sub> (***)	9,0	10,4	9,0	10,5	9,0	10,4	9,0	10,4	9,0	10,4
	p.p.m.	NOx s.a. lower than	30,0	40,0	30,0	40,0	30,0	40,0	30,0	40,0	30,0	40,0
	°C	T flue gases	61,0		61,0		62,0		61,0		61,0	
<b>FOR COMBINED HEATING APPLIANCES</b>												
Water heating energy efficiency $\eta_{wh}$	%	-	-	-	-	-	-	-	-	-	-	
Daily electrical energy consumption Qelec	kWh	-		-		-		-		-		
Daily fuel consumption Qfuel	kWh	-		-		-		-		-		
Annual electrical energy consumption AEC	kWh	-		-		-		-		-		
Annual fuel consumption AFC	GJ	-		-		-		-		-		

(\*\*) Weights calculated according to standard EN 15502.

(\*\*\*) Values referred to atmospheric pressure at sea level.

## CONDENSING GENERATORS

Indoor/Outdoor floor standing gas condensing modules

### ERP DATA 300-3 P - 540-4 P

STEEL PRO POWER MODELS	U.M.	300-3 P		345-3 P		405-3 P		460-4 P		540-4 P		
		G20	G31	G20	G31	G20	G31	G20	G31	G20	G31	
Seasonal ambient heating energy efficiency class	%	-	-	-	-	-	-	-	-	-	-	
Nominal output	kW	291,0		336,0		393,0		448,0		524,0		
Seasonal ambient heating energy efficiency $\eta_s$	%	93		93		93		93		93		
<b>EFFECTIVE HEAT OUTPUT</b>												
At nominal heat output and in high temperature mode P4	kW	285,9	-	329,4	-	387,0	-	439,2	-	516,0	-	
At 30% of nominal heat output and in low temperature mode P1	kW	95,1	-	109,8	-	129,0	-	146,4	-	172,0	-	
<b>EFFICIENCY</b>												
At nominal heat output and in high temperature mode $\eta_4$ (GCV)	%	88,24		88,55		88,36		88,55		88,36		
At 30% of nominal heat output and in low temperature mode $\eta_1$ (GCV)	%	97,84		98,39		98,17		98,39		98,17		
<b>AUXILIARIES ELECTRICITY CONSUMPTION</b>												
With full load Elmax	W	951		1059		1446		1412		1928		
With partial load Elmin	W	228		297		330		396		440		
In standby mode PSB	W	18		18		24		24		32		
<b>OTHER PARAMETERS</b>												
Heat losses in Pstby standby mode	W	414,19		474,96		561,71		636,09		748,95		
Energy consumption of the Pign pilot flame	W	-		-		-		-		-		
Annual energy consumption QHE	GJ	588,0		678,0		798,0		904,0		1064,0		
Sound power level indoors LWA	dB(A)	60,00		61,00		62,00		63,00		64,00		
Nitrogen oxide emissions Nox (**)	mg/kWh	38,70		39,30		46,10		39,30		46,10		
Nox class	n°	6		6		6		6		6		
Emission values at maximum and minimum output (**)		G20	G31	G20	G31	G20	G31	G20	G31	G20	G31	
Maximum	p.p.m.	CO s.a. lower than	91,5	163,0	89,0	177,0	91,5	185,0	89,0	177,0	91,5	185,0
	%	CO <sub>2</sub> (***)	9,0	10,4	9,0	10,4	9,0	10,4	9,0	10,4	9,0	10,4
	p.p.m.	NOx s.a. lower than	30,0	40,0	30,0	40,0	30,0	40,0	30,0	40,0	30,0	40,0
	°C	T flue gases	78,0		75,0		77,0		75,0		77,0	
Minimum	p.p.m.	CO s.a. lower than	7,5	12,0	4,6	14,0	5,6	16,0	4,6	14,0	5,6	16,0
	%	CO <sub>2</sub> (***)	9,0	10,4	9,0	10,4	9,0	10,4	9,0	10,4	9,0	10,4
	p.p.m.	NOx s.a. lower than	30,0	40,0	30,0	40,0	30,0	40,0	30,0	40,0	30,0	40,0
	°C	T flue gases	62,0		61,0		61,0		61,0		61,0	
<b>FOR COMBINED HEATING APPLIANCES</b>												
Water heating energy efficiency $\eta_{wh}$	%	-		-		-		-		-		
Daily electrical energy consumption Qelec	kWh	-		-		-		-		-		
Daily fuel consumption Qfuel	kWh	-		-		-		-		-		
Annual electrical energy consumption AEC	kWh	-		-		-		-		-		
Annual fuel consumption AFC	GJ	-		-		-		-		-		

(\*\*) Weights calculated according to standard EN 15502.

(\*\*\*) Values referred to atmospheric pressure at sea level.

### RESIDUAL DISCHARGE HEAD

Maximum residual discharge head curve related to 2 modules

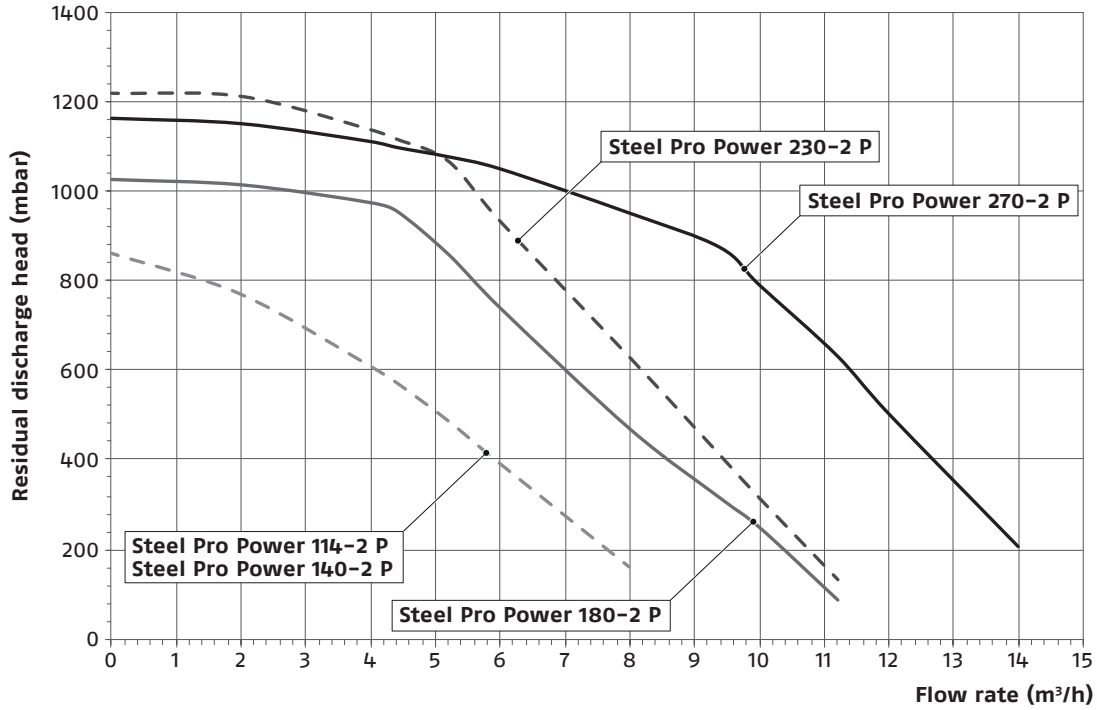

Maximum residual discharge head curve related to 3-4 modules

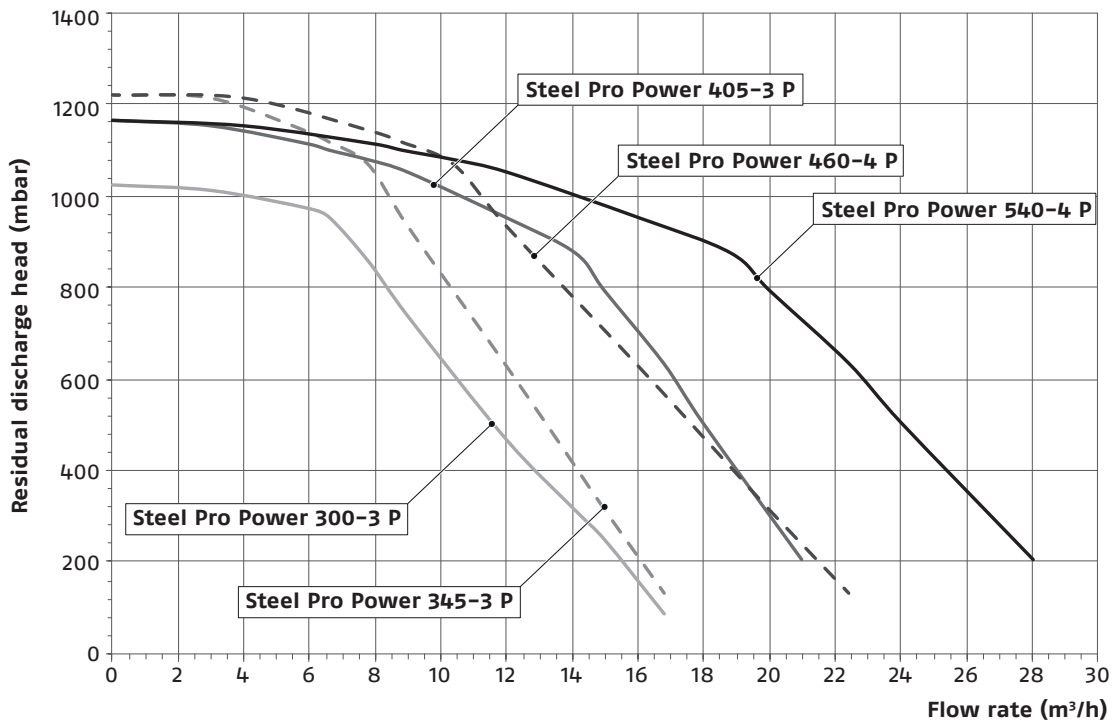

# CONDENSING GENERATORS

Indoor/Outdoor floor standing gas condensing modules

## OVERALL DIMENSIONS AND COUPLINGS

### MODELS

114 - 2 P

140 - 2 P

180 - 2 P

230 - 2 P

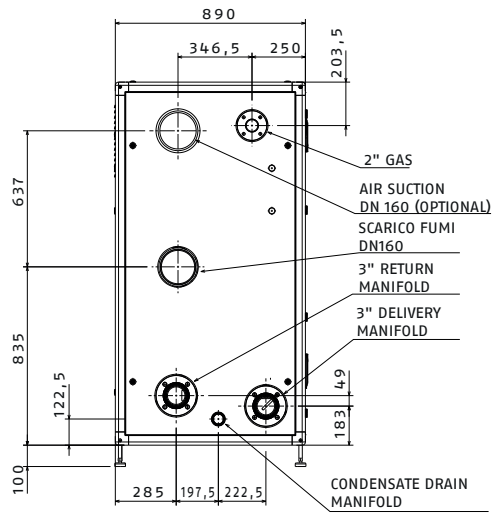
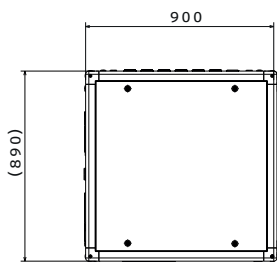
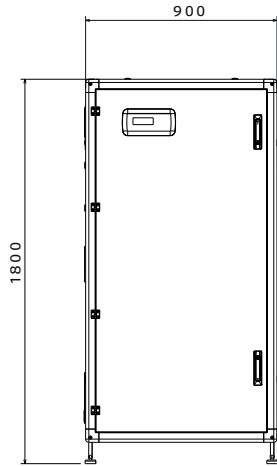

### MODELS 270 - 2 P

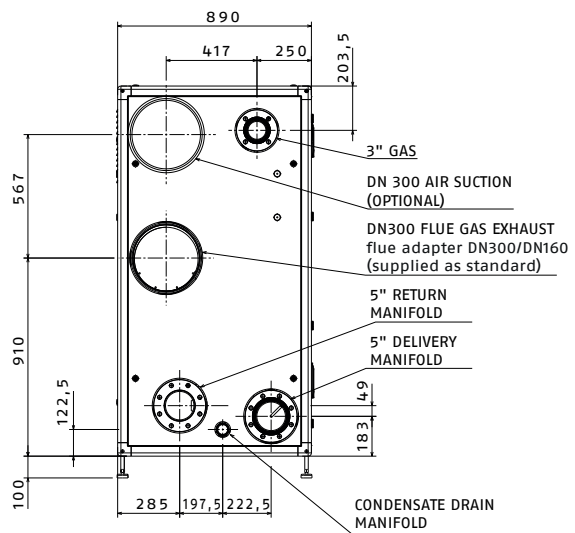
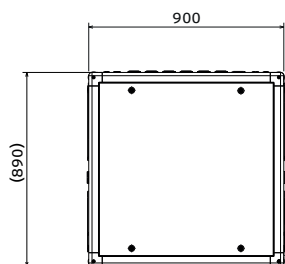
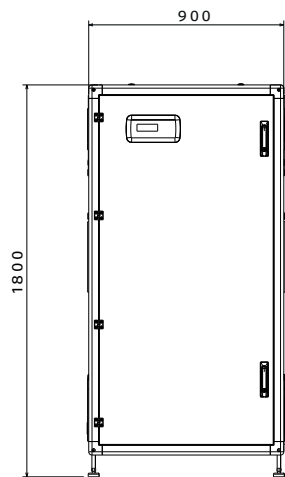

MODELS  
300 - 3 P  
345 - 3 P  
460 - 4 P

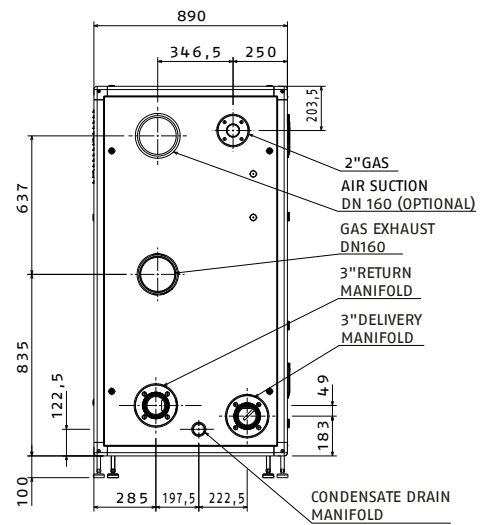
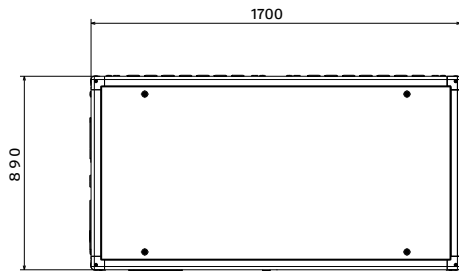
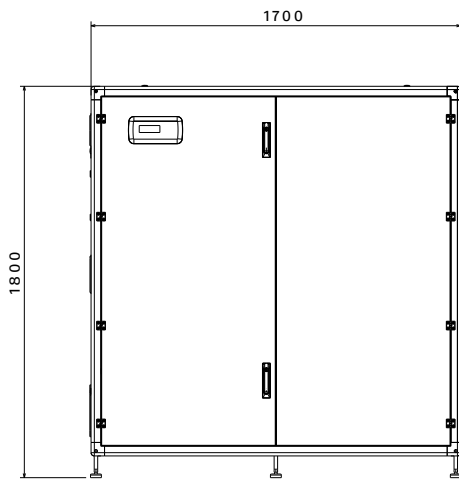

MODELS  
405 - 3 P  
540 - 4 P

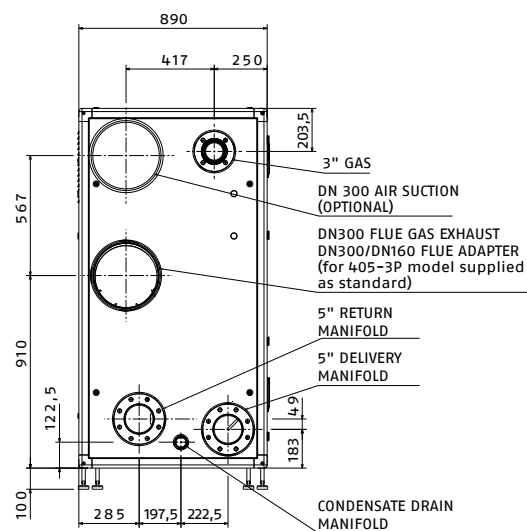
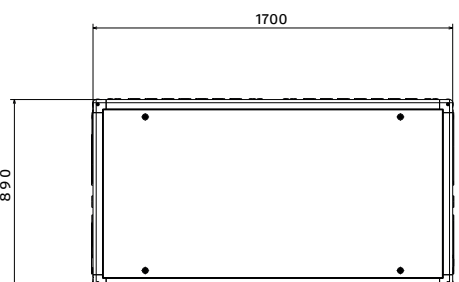
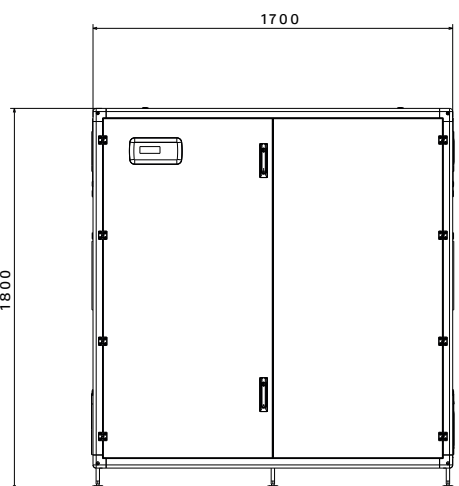

## CONDENSING GENERATORS

Indoor/Outdoor floor standing gas condensing modules

	U.M.	STEEL PRO POWER 114-2 P	STEEL PRO POWER 140-2 P	STEEL PRO POWER 180-2 P	STEEL PRO POWER 230-2 P	STEEL PRO POWER 270-2 P
Heating delivery diameter	Ø DN	3" DN80 PN6	3" DN80 PN6	3" DN80 PN6	3" DN80 PN6	5" DN125 PN6
Heating return diameter	Ø DN	3" DN80 PN6	3" DN80 PN6	3" DN80 PN6	3" DN80 PN6	5" DN125 PN6
Gas input diameter	Ø DN	2" DN50 PN6	2" DN50 PN6	2" DN50 PN6	2" DN50 PN6	3" DN80 PN6
Condensate drain diameter	Ø (mm)	50	50	50	50	50
Casing height	mm	1800	1800	1800	1800	1800
Casing width	mm	900	900	900	900	900
Casing depth	mm	890	890	890	890	890
Flue gases exhaust diameter	Ø (mm)	DN160	DN160	DN160	DN160	DN300
Air suction diameter (optional)	Ø (mm)	DN160	DN160	DN160	DN160	DN300
Empty weight	kg	270	270	280	300	350

	U.M.	STEEL PRO POWER 300-3 P	STEEL PRO POWER 345-3 P	STEEL PRO POWER 405-3 P	STEEL PRO POWER 460-4 P	STEEL PRO POWER 540-4 P
Heating delivery diameter	Ø DN	3" DN80 PN6	3" DN80 PN6	5" DN125	3" DN80 PN6	5" DN125
Heating return diameter	Ø DN	3" DN80 PN6	3" DN80 PN6	5" DN125	3" DN80 PN6	5" DN125
Gas input diameter	Ø DN	2" DN50 PN6	2" DN50 PN6	3" DN80 PN6	2" DN50 PN6	3" DN80 PN6
Condensate drain diameter	Ø (mm)	50	50	50	50	50
Casing height	mm	1800	1800	1800	1800	1800
Casing width	mm	1800	1800	1800	1800	1800
Casing depth	mm	890	890	890	890	890
Flue gases exhaust diameter	Ø (mm)	DN160	DN160	DN300	DN160	DN300
Air suction diameter (optional)	Ø (mm)	DN160	DN160	DN300	DN160	DN300
Empty weight	kg	450	490	540	560	600

## MODELS AND CASCADE OUTPUTS STRUCTURE RANGE

6 possible configurations for cascade systems with powers from 655 up to 1310 kW

STEEL PRO POWER 675 System	393	262	655	
STEEL PRO POWER 810 System	524	262	786	
STEEL PRO POWER 945 System	524	393	917	
STEEL PRO POWER 1080 System	524	524	1048	
STEEL PRO POWER 1215 System	524	393	262	1179
STEEL PRO POWER 1350 System	524	524	262	1310

## COMPONENT OVERVIEW 114-2 P ÷ 270-2 P

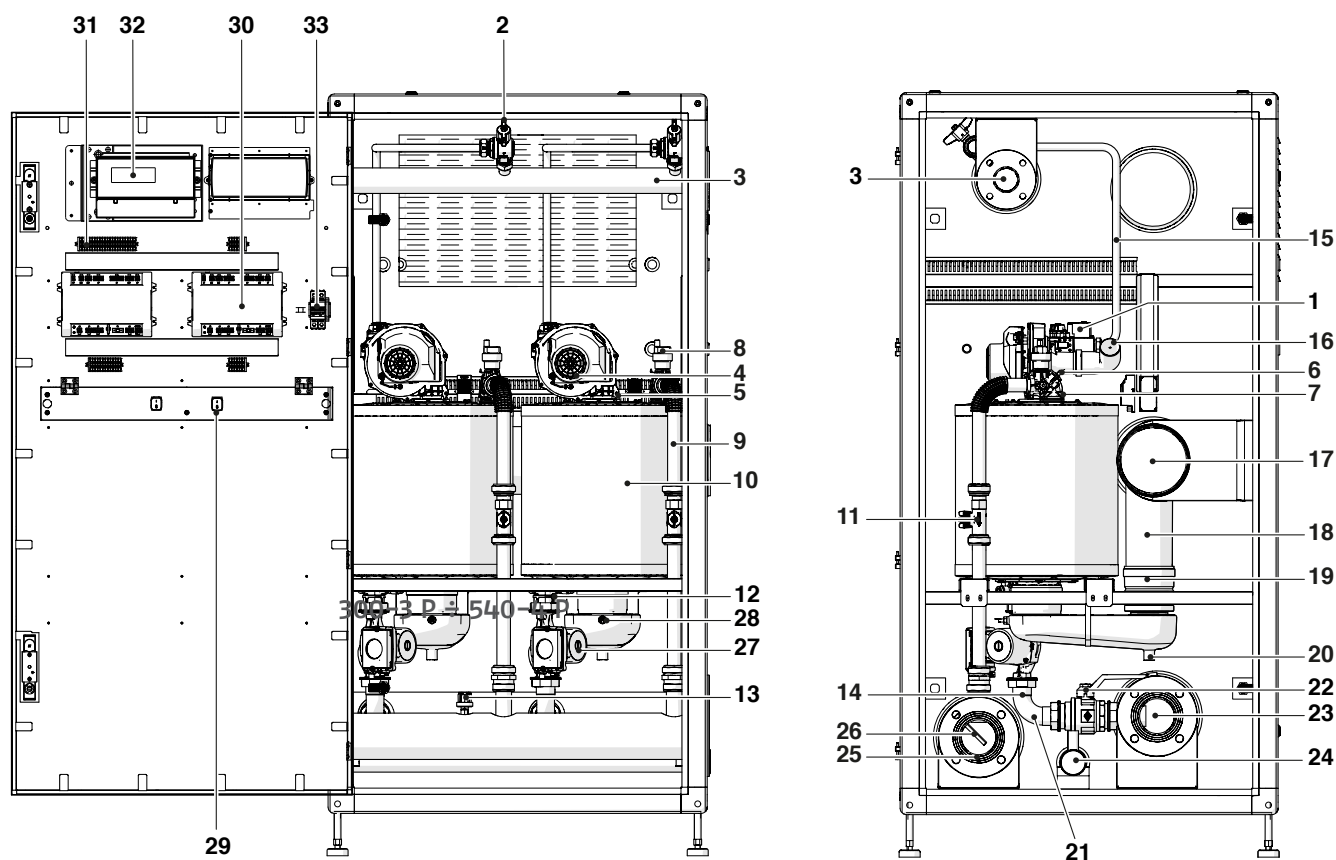

- |  |                               |
|--|-------------------------------|
| 1. Gas valve                                 | 18. Flue exhaust pipe unit    |
| 2. Gas cock                                  | 19. Clapet unit               |
| 3. Gas manifold                              | 20. Condensate drain unit     |
| 4. Fan                                       | 21. Return pipe unit          |
| 5. Electrode                                 | 22. Two-way valve return unit |
| 6. Flow probe                                | 23. Water return manifold     |
| 7. Safety thermostat with reset by the board | 24. Condensate collector      |
| 8. Automatic bleed valve                     | 25. Water flow manifold       |
| 9. Delivery pipe unit                        | 26. Delivery probe socket     |
| 10. Combustion chamber                       | 27. Unit pump                 |
| 11. Flow-meter                               | 28. Exhaust flue probe        |
| 12. Unit return probe                        | 29. Unit switch               |
| 13. Minimum pressure switch                  | 30. Control board             |
| 14. Unit drain valve                         | 31. Terminal strip            |
| 15. Gas pipe unit                            | 32. Display                   |
| 16. Unit inlet pipe                          | 33. Mains power switch        |
| 17. Flue collector                           |                               |

# CONDENSING GENERATORS

Indoor/Outdoor floor standing gas condensing modules

## COMPONENT OVERVIEW 300-3 P ÷ 540-4 P

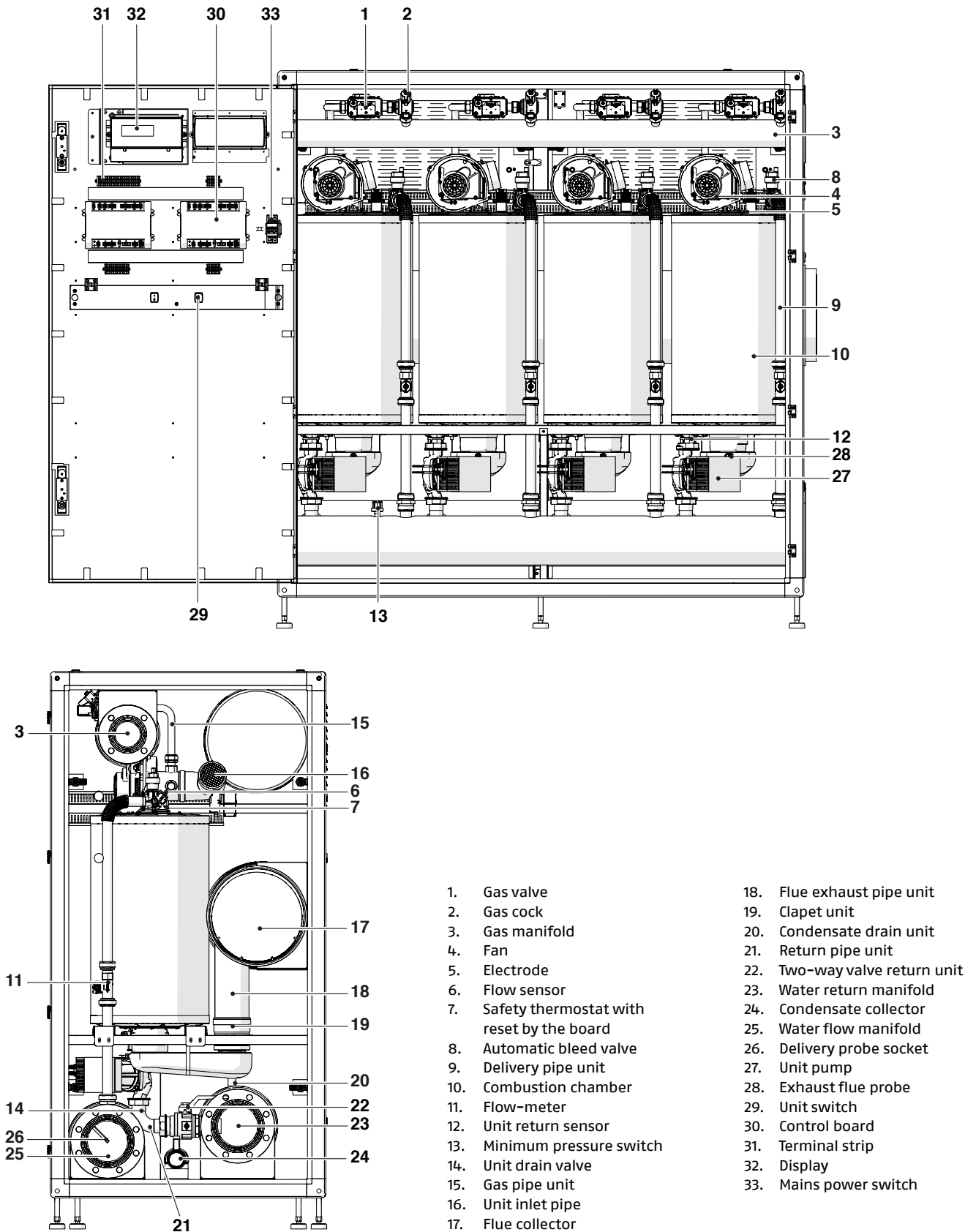

## HEAT EXCHANGER CHARACTERISTICS

The heat exchanger consists of two stainless steel caps that act also as flow and return hydraulic manifolds; between the two caps two 316-mm austenitic stainless steel coils are connected, with a thickness of 1.2 mm in which the system water flows in parallel. The first is made of a plain tube with a pentagonal section (innermost) and a second one with a circular section (outermost). The hot flue gases leave the burner (driven by the fan) and they first reach the surface of the pentagonal pipe and then of the circular pipe, allowing a rapid reduction of the flue gas temperature and an efficient heating of the water, which flows in parallel from the lower cap (upwards) inside the two coils and is sent to the utility from the upper cap. The drawing shows the main water, gas, condensate and flue gas flows inside the heat exchanger.

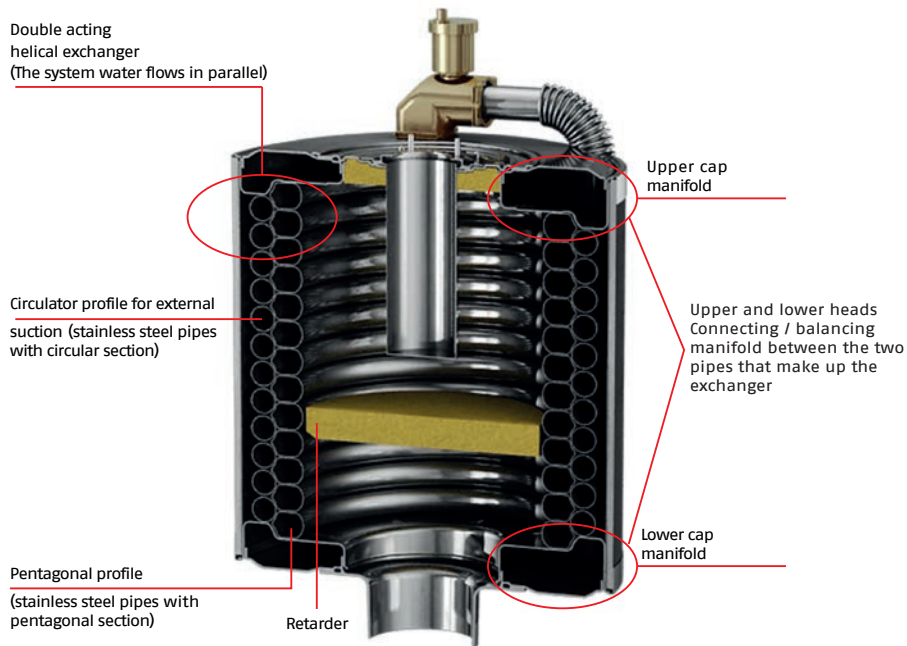

## FUNCTIONING PRINCIPLE

The combustion products flow along the double acting helical exchanger and transfer sensible heat to the water

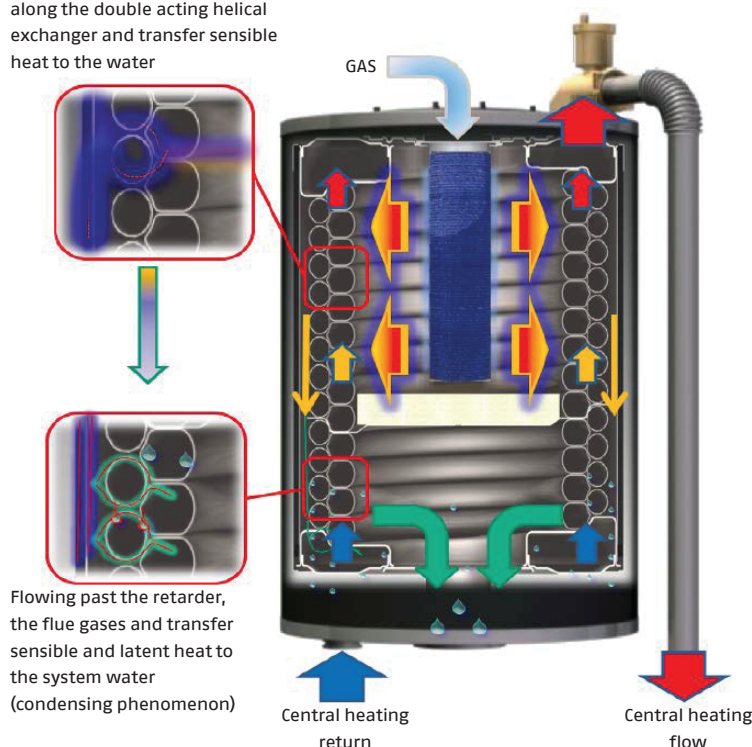

## CONDENSING GENERATORS

Indoor/Outdoor floor standing gas condensing modules

### FLUE GAS COLLECTOR

All STEEL PRO POWER models are equipped with a flue gas check valve located inside the flue gas conveyor, at the bottom of each thermal module.

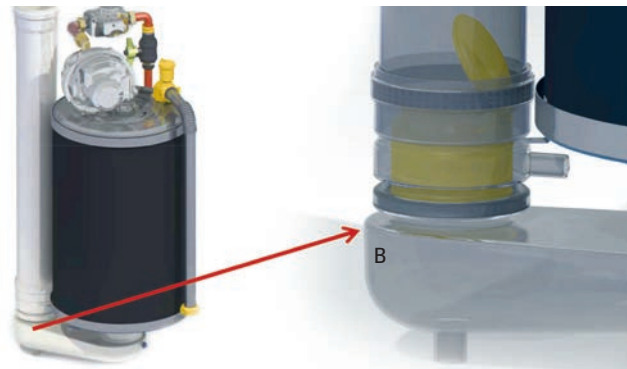

A

A: Exhaust for condensate produced within the heat exchanger  
B: Exhaust for residual condensate within the exhaust pipe,  
(stops the condensate from accumulating above the check  
valve preventing its correct opening)

## ACCESSORIES

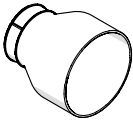
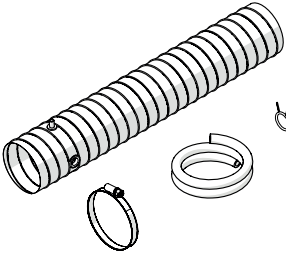
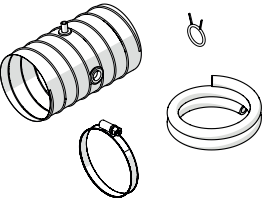
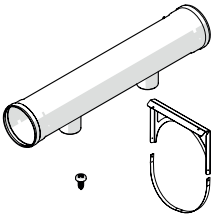
SEALED COMBUSTION CONVERSION KIT (TYPE C)		STEEL PRO POWER															
	DESCRIPTION	114-2 P	140-2 P	180-2 P	230-2 P	270-2 P	300-3 P	345-3 P	405-3 P	460-4 P	540-4 P	SYSTEM 675	SYSTEM 810	SYSTEM 945	SYSTEM 1080	SYSTEM 1215	SYSTEM 1350
	<p><b>Adapter Ø50/80 mm</b> PP 50/80 adapter to be connected to the fan of each heater in case of sealed conversion (Type C) for Steel Pro Power models. 114-2, 140-2 to allow connection between the fan and the fan/collector air pipe kit 160 mm.</p>	2x	2x														
	<p><b>Air pipe kit for fan/collector connection Ø160 mm</b> Sealed combustion conversion kit (Type C) for Steel Pro Power 114-2, 140-2, 180-2, 230-2, 300-3, 345-3, 460-4 models. Suitable when the boiler must be sealed off from the environment. The accessory allows connection of the boiler to the air intake duct.</p> <p>Consisting of:</p> <ul style="list-style-type: none"> <li>- flexible combustion air intake pipe (DN93 L=540mm) to connect the fan intake to the air manifold;</li> <li>- compensation pipe (made of silicone D.8x4mm L=760mm) for the pneumatic gas valve, connection between air intake and gas valve) to allow correct modulation;</li> <li>- necessary clamps, screws and gaskets.</li> </ul> <p>The accessory is dedicated to a single unit, therefore to make a cabinet watertight it is necessary to order as many kits as there are units contained in the cabinet.</p>	2x	2x	2x	2x		3x	3x		4x							
	<p><b>Air hose kit for fan/collector connection Ø300 mm</b> Sealed combustion conversion kit (Type C) for Steel Pro Power 270-2, 405-3, 540-4 models. Suitable in cases where the boiler must be sealed off from the environment. The accessory allows the connection of the boiler to the air intake duct.</p> <p>Consisting of:</p> <ul style="list-style-type: none"> <li>- flexible combustion air intake pipe (DN93 L=160mm) to connect the fan intake to the air manifold;</li> <li>- compensation pipe (made of silicone D.8x4mm L=680mm) for the pneumatic gas valve, connection between air intake and gas valve) to allow correct modulation;</li> <li>- necessary clamps, screws and gaskets.</li> </ul> <p>The accessory is dedicated to a single unit, therefore to make a cabinet watertight it is necessary to order as many kits as there are units contained in the cabinet</p>					2x			3x	4x	5x	6x	7x	8x	9x	10x	
	<p><b>Air manifold for models Ø160 mm - for models with 2 heat modules</b> PP air manifold, Ø160mm, L=900mm for airtight combustion conversion (Type C) of models 114-2, 140-2, 180-2, 230-2. To be installed directly inside the boiler cabinet, it must be installed together with the fan/air manifold air pipe kit Ø160 mm. The kit includes the necessary brackets and clamps for installation.</p>	1x	1x	1x	1x												

## CONDENSING GENERATORS

Indoor/Outdoor floor standing gas condensing modules

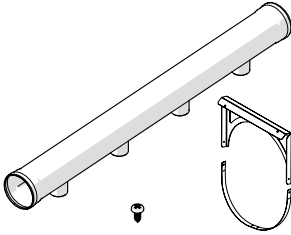
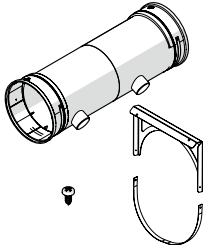
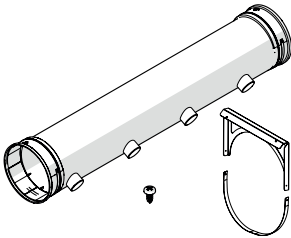
SEALED COMBUSTION CONVERSION KIT (TYPE C)		STEEL PRO POWER																
	DESCRIPTION	114-2 P	140-2 P	180-2 P	230-2 P	270-2 P	300-3 P	345-3 P	405-3 P	460-4 P	540-4 P	SYSTEM 675	SYSTEM 810	SYSTEM 945	SYSTEM 1080	SYSTEM 1215	SYSTEM 1350	
	<b>Flue collector for models Ø160 mm - for models with 3/4 heating modules</b> PP flue collector, Ø160mm, L=1800mm for airtight combustion conversion (Type C) for models 300-3, 345-3, 460-4. To be installed directly inside the boiler cabinet, it must be installed together with the fan air pipe/collector kit Ø160mm. The kit includes the necessary brackets and clamps for installation. The flue collector is fitted with a cap so that it can also be combined with cabinets containing only 3 units.						1x	1x		1x								
	<b>Flue collector for models Ø300 mm - for models with 2 heat modules</b> PP flue collector, Ø300mm, L=900mm for conversion to sealed combustion (Type C) for model 270-2. To be installed directly inside the boiler cabinet, it must be installed together with the fan/air manifold air pipe kit Ø300 mm. The kit includes the necessary brackets and clamps for installation					1x						1x	1x				1x	1x
	<b>Flue collector for models Ø300 mm - for models with 3/4 heat modules</b> PP flue collector, Ø300mm, L=1800mm for conversion to sealed combustion (Type C) for models 405-3, 540-4. To be installed directly inside the boiler cabinet, it must be installed together with the fan air manifold /flue collector kit Ø300mm. The kit includes the necessary brackets and clamps for installation. The flue collector is fitted with a cap so that it can also be combined with cabinets containing only 3 units.								1x	1x	1x	1x	2x	2x	2x	2x	2x	2x

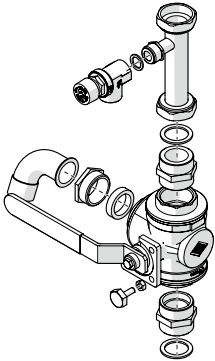
HYDRAULIC INTERCEPTION OF THERMAL MODULES		STEEL PRO POWER															
	DESCRIPTION	114-2 P	140-2 P	180-2 P	230-2 P	270-2 P	300-3 P	345-3 P	405-3 P	460-4 P	540-4 P	SYSTEM 675	SYSTEM 810	SYSTEM 945	SYSTEM 1080	SYSTEM 1215	SYSTEM 1350
	<b>Hydraulic shut-off kit for single unit with 3-way valve with exhaust to atmosphere</b> The kit has been designed to facilitate maintenance and cleaning operations of the single units, without stopping the operation of the entire cabinet; the careful study allows the kit to be installed in place of the standard nozzle (without any interception) located on the delivery of each single unit, and consists of: - a 3-way ball valve 1" 1/2 (with exhaust to atmosphere); - a safety valve (5.4 bar FF 3/4") approved CE.	2x	2x	2x	2x	2x	3x	3x	3x	4x	4x	5x	6x	7x	8x	9x	10x

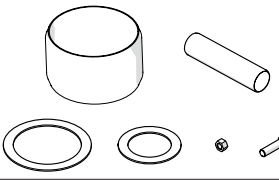
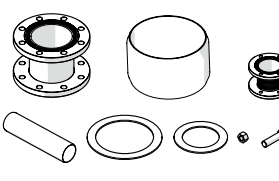
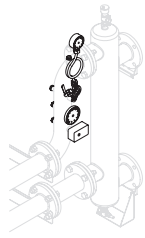
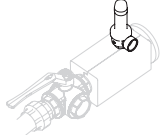
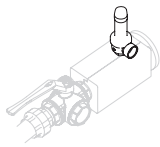
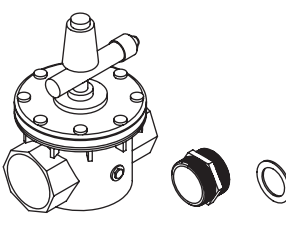
CONNECTIONS AND SAFETY ACCESSORIES		STEEL PRO POWER															
	DESCRIPTION	114-2 P	140-2 P	180-2 P	230-2 P	270-2 P	300-3 P	345-3 P	405-3 P	460-4 P	540-4 P	SYSTEM 675	SYSTEM 810	SYSTEM 945	SYSTEM 1080	SYSTEM 1215	SYSTEM 1350
	<p><b>Kit for connecting cabinets in cascade (Flue Ø300 - Air Ø300 - Condensate Ø50)</b> Kit for the connection of two adjacent cabinets to obtain direct side-by-side cascade, consisting of:</p> <ul style="list-style-type: none"> <li>- 2 air/flue gas spacers DN300 L = 150 mm;</li> <li>- PP pipe DN50 L = 110 mm condensate flue junction.</li> </ul>											1x	1x	1x	1x	2x	2x
	<p><b>Spacer kit (150 mm) for cascade cabinet connection</b> Kit for side-by-side cascade installation using spacers, which can be used when cabinets are not perfectly aligned. The kit consists of:</p> <ul style="list-style-type: none"> <li>- 2 spacers 5" PN6 DN125, L = 152 mm;</li> <li>- 2 air/flue spacers DN300, L = 198 mm;</li> <li>- PP spacer, DN50, L = 198 mm (condensate flue collector);</li> <li>- vibration-damping joint kit DN80 PN6.</li> </ul>											1x	1x	1x	1x	2x	2x
	<p><b>Safety kit</b> Set of safety devices. The kit includes:</p> <ul style="list-style-type: none"> <li>- Thermometer</li> <li>- Pressure gauge</li> <li>- Safety pressure switch.</li> </ul> <p>Note: does not include safety valve and fuel shut-off valve, to be ordered separately in relation to the maximum power of the system.</p>	1x	1x	1x	1x	1x	1x	1x	1x	1x	1x	1x	1x	1x	1x	1x	1x
	<p><b>Safety valve 5.4 bar ØG.3/4" (up to 460 kW)</b> Safety valve up to 460 kW (5.4 bar ØG.3/4 "F) Approved safety valve Ø3/4 "G. Calibration pressure: 5.4 bar Maximum discharge capacity: 460 kW</p>	1x	1x	1x	1x	1x	1x	1x	1x	1x		2x	2x	2x	3x	3x	3x
	<p><b>Safety valve 5.4 bar ØG.1" (up to 580 kW)</b> Safety valve up to 580 kW (5.4 bar ØG.1 "F) Approved safety valve Ø1 "G. Pressure setting: 5.4 bar Maximum discharge capacity: 580 kW</p>										1x						
	<p><b>Fuel shut-off valve (VIC) - ØG.1"</b> 1" positive-acting fuel shut-off valve (VIC) with manual reset. Liquid-expansion thermostatic element with an operating temperature of 97 °C (±3 °C); Capillary length 5 m. Sensor sheath connection 1/2 "M (complete with 1/2 "F x 3/4 "M nipple). Use limit: 131 kW with gas supply pressure = 20 mbar Compliant with I.S.P.E.S.L. standard. : - D.M. 1/12/1975 Collection R (ed. June '82) and subsequent updates. - PED 97/23/CEE, ATEX 94/9/CEE approved.</p>	1x															

## CONDENSING GENERATORS

Indoor/Outdoor floor standing gas condensing modules

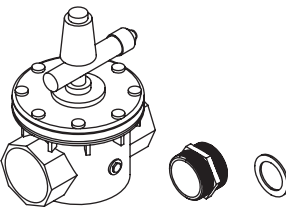
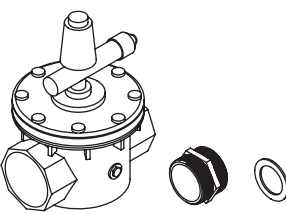
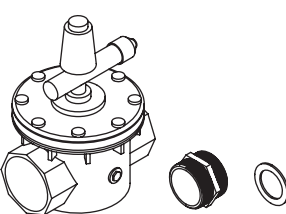
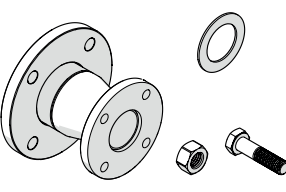
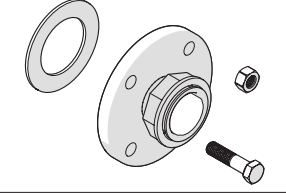
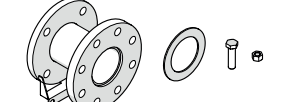
CONNECTIONS AND SAFETY ACCESSORIES		STEEL PRO POWER																
	DESCRIPTION	114-2 P	140-2 P	180-2 P	230-2 P	270-2 P	300-3 P	345-3 P	405-3 P	460-4 P	540-4 P	SYSTEM 675	SYSTEM 810	SYSTEM 945	SYSTEM 1080	SYSTEM 1215	SYSTEM 1350	
			<p><b>Fuel shut-off valve (VIC) – ØG.1"½</b> 1"½ positive-acting fuel shut-off valve (VIC) with manual reset. Liquid-expansion thermostatic element with an operating temperature of 97 °C (±3 °C): Capillary length 5 m. Sensor sheath connection 1/2 "M (complete with 1/2 "F x 3/4 "M nipple). Operating limit: 230 kW with gas supply pressure = 20 mbar Compliant with I.S.P.E.L. standard. : - D.M. 1/12/1975 Collection R (ed. June '82) and subsequent updates. - Approved PED 97/23/CEE, ATEX 94/9/CEE</p>		1x	1x	1x											
	<p><b>Fuel shut-off valve (VIC) – ØG.2"</b> 2" positive-acting fuel shut-off valve (VIC) with manual reset. Liquid-expansion thermostatic element with an operating temperature of 97 °C (±3 °C): Capillary length 5 m. Sensor sheath connection 1/2 "M (complete with 1/2 "F x 3/4 "M nipple). 580 kW with gas supply pressure = 20 mbar. Compliant with I.S.P.E.S.L. standard. : - D.M. 1/12/1975 Collection R (ed. June '82) and subsequent updates. - PED 97/23/CEE, ATEX 94/9/CEE approved.</p>					1x	1x	1x	1x	1x								
	<p><b>Fuel shut-off valve (VIC) – ØG.3"</b> 3" positive-acting fuel shut-off valve (VIC) with manual reset. Liquid-expansion thermostatic element with an operating temperature of 97 °C (±3 °C): Capillary length 5 m. Sensor sheath connection 1/2 "M (complete with 1/2 "F x 3/4 "M nipple). Operating limit: 1310 kW with gas supply pressure = 20 mbar Compliant with I.S.P.E.S.L. standard. : - D.M. 1/12/1975 Collection R (ed. June '82) and subsequent updates. - Approved PED 97/23/CEE, ATEX 94/9/CEE.</p>										1x	1x	1x	1x	1x	1x	1x	
	<p><b>Reduction kit 3"½" flanged (DN80/DN50)</b> Kit used to connect 1", 1"½, 2" VIC valves, respectively for 270-2, 405-3 and 540-4 cabinets in case of STAND ALONE installation. Consisting of: - a diameter reduction in FE, flanged 3" – 2"; - insulation; - gaskets and bolts for installation.  The kit is ambidextrous and is therefore suitable for installation both on the right and left side of Steel Pro Power. It must be coupled with the 2" DN50 PN6 – 2" G.F flange kit in order to connect the above mentioned VICs with F threaded connection.</p>					1x		1x		1x								
	<p><b>Flange kit 2" DN50 PN6 – Gas 2" F</b> Adapter kit for connection of 2" VIC valves, in cases where there is no technical cabinet. The kit consists of a flange adaptor 2 "PN6 – 2" F threaded.</p>	1x	1x	1x	1x	1x	1x	1x	1x	1x								
	<p><b>Flange kit 3" DN80 PN6 – 3" DN80 PN16</b> Adapter kit for connection of 3" VIC valves in case of cascade cabinets. The kit consists of a flange adaptor 3" DN80 PN6 – 3" DN80 PN16.</p>										1x	1x	1x	1x	1x	1x		

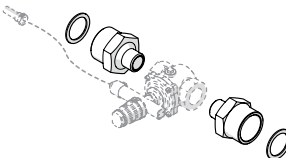
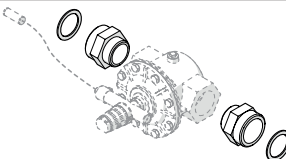
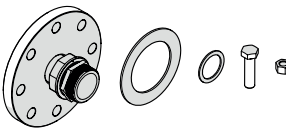
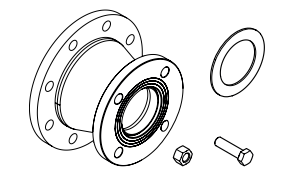
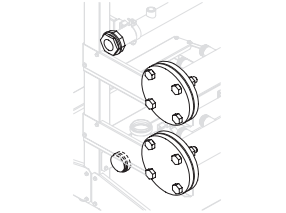
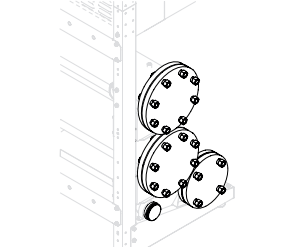
CONNECTIONS AND SAFETY ACCESSORIES																	
	DESCRIPTION	STEEL PRO POWER															
		114-2 P	140-2 P	180-2 P	230-2 P	270-2 P	300-3 P	345-3 P	405-3 P	460-4 P	540-4 P	SYSTEM 675	SYSTEM 810	SYSTEM 945	SYSTEM 1080	SYSTEM 1215	SYSTEM 1350
	<b>Gas adapter 2" - 1" for VIC valve</b>	1x															
	<b>Gas adapter 2" - 1" 1/2 for VIC valve</b>		1x	1x	1x												
	<b>Adapter kit for VIC valve flanged from DN80 to threaded ØG.2".</b> Adapter kit for the connection of the VIC valve to the cascade cabinets (270-2, 405-3, 540-4), in case they are installed STAND ALONE in combination with a technical cabinet. The kit consists of two DN80/DN50 flanged brackets for the connection of the 2" VIC valve.									1x							
	<b>Flanged reduction kit DN125/DN80</b> Kit used for hydraulic connection of cabinets 270-2, 405-3 STAND ALONE, consisting of: - a diameter reduction in FE, flanged 5" - 3"; - insulation; - gaskets and bolts for installation.  The kit is ambidextrous and is therefore suitable for both left and right hand installations of Steel Pro Power.					2x		2x									
	<b>3" end cap kit</b> The kit allows to close the water (flow and return), gas and condensate discharge manifolds in order to intercept the unused side. It includes - nr.2 DN80 blind flanges for 3" manifolds for flow/return water; - 1 threaded plug for 2" gas manifold; - nr.1 cap for condensate discharge manifold; - gaskets; - fixing bolts.	1x	1x	1x	1x		1x	1x		1x							
	<b>5" end cap kit</b> The kit allows to close the water (flow and return), gas and condensate discharge manifolds in order to intercept the unused side. It includes: - nr.2 blind flanges DN125 for 5" manifolds for flow/return water; - nr.1 threaded cap for 3" gas manifold; - nr.1 cap for condensate discharge manifold; - gaskets; - fixing bolts.					1x			1x		1x	1x	1x	1x	1x	1x	1x

## CONDENSING GENERATORS

Indoor/Outdoor floor standing gas condensing modules

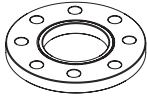
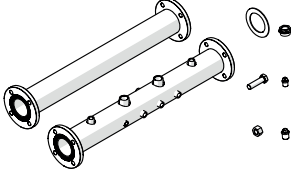
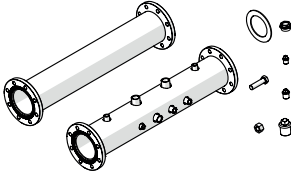
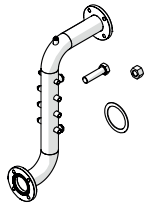
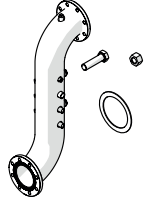
CONNECTIONS AND SAFETY ACCESSORIES		STEEL PRO POWER																
	DESCRIPTION	114-2 P	140-2 P	180-2 P	230-2 P	270-2 P	300-3 P	345-3 P	405-3 P	460-4 P	540-4 P	SYSTEM 675	SYSTEM 810	SYSTEM 945	SYSTEM 1080	SYSTEM 1215	SYSTEM 1350	
			<p><b>3" welding flange kit</b> This kit is used to connect the manifolds (flow and return) to the rest of the hydraulic system. It consists of:</p> <ul style="list-style-type: none"> <li>- nr.1 counter-flange to be welded (3" DN80 - PN6);</li> <li>- gaskets and bolts for installation.</li> </ul> <p>Therefore, for a complete supply, it is necessary to provide 2 kits (flow and return manifolds)</p>	2x	2x	2x	2x	2x	2x	2x	2x	2x						
	<p><b>5" welding flange kit</b> This kit is used to connect the manifolds (flow and return) to the rest of the hydraulic system. It consists of:</p> <ul style="list-style-type: none"> <li>- nr.1 counter-flange to be welded (5" DN125 - PN6);</li> <li>- gaskets and bolts for installation.</li> </ul> <p>Therefore, for a complete supply, it is necessary to foresee 2 kits (flow and return manifolds).</p>										2x	2x	2x	2x	2x	2x	2x	
	<p><b>3" straight extension kit with safety wells</b> Kit of extension pipes for safety group. The kit consists of two 3" extensions (supply and return) with DN80 - PN6 flanges (length approx. 900 mm), insulation, gaskets and tightening bolts. On the delivery connection there are the housings for installing the safety kit. This accessory can be used on its own (for installation in a central heating plant) or in combination with a cover cabinet of about 900 mm width (for installation in a central heating plant or outdoor).</p>	1x	1x	1x	1x	1x	1x	1x	1x	1x								
	<p><b>5" straight extension kit with safety wells</b> Extension kit for safety group. The kit is composed of two 5" extensions (flow and return) with DN125 - PN6 flanges (about 900 mm long), insulation, gaskets and tightening bolts. On the delivery pipe there are the housings to install the safety kit. This accessory can be used on its own (for installation in a central heating plant) or in combination with a 900 mm wide covering cabinet (for installation in a central heating plant or outdoor).</p>					1x		1x		1x	1x	1x	1x	1x	1x	1x	1x	
	<p><b>3" Kit flow manifold for LLH connection with ready safety devices sockets connections</b> Kit consisting of:</p> <ul style="list-style-type: none"> <li>- 3" manifold in FE for housing the safety devices ;</li> <li>- insulation of the manifold;</li> <li>- gaskets and bolts for installation.</li> </ul> <p>The kit is ambidextrous and is therefore suitable for installation both on the right and left side of Steel Pro Power.</p>	1x	1x	1x	1x	1x	1x	1x	1x	1x								
	<p><b>5" Kit flow manifold for LLH connection with ready safety devices sockets connections</b> Kit composed by:</p> <ul style="list-style-type: none"> <li>- 5" FE manifold for housing the safety devices;</li> <li>- insulation of the manifold;</li> <li>- gaskets and bolts for installation.</li> </ul> <p>The kit is ambidextrous and is therefore suitable for installation both on the right and left side of Steel Pro Power.</p>					1x		1x		1x	1x	1x	1x	1x	1x	1x	1x	

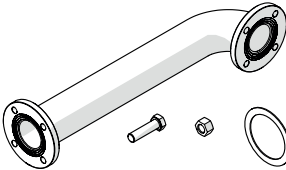
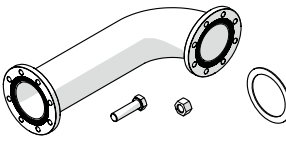
CONNECTIONS AND SAFETY ACCESSORIES		STEEL PRO POWER															
	DESCRIPTION	114-2 P	140-2 P	180-2 P	230-2 P	270-2 P	300-3 P	345-3 P	405-3 P	460-4 P	540-4 P	SYSTEM 675	SYSTEM 810	SYSTEM 945	SYSTEM 1080	SYSTEM 1215	SYSTEM 1350
	<p><b>3" Kit return manifold for LLH connection with ready safety devices sockets connections</b> Kit composed of:</p> <ul style="list-style-type: none"> <li>- 3" FE return nozzle, complementary to flow manifold for the safety valves;</li> <li>- insulation of the manifold;</li> <li>- gaskets and bolts for installation.</li> </ul> <p>The kit is ambidextrous and is therefore suitable for installation both on the right and left side of Steel Pro Power.</p>	1x	1x	1x	1x	1x	1x	1x	1x	1x							
	<p><b>5" Kit return manifold for LLH connection with ready safety devices sockets connections</b> Kit composed by:</p> <ul style="list-style-type: none"> <li>- 5" FE return manifold , complementary to flow manifold for safety devices;</li> <li>- insulation of the manifold;</li> <li>- gaskets and bolts for installation.</li> </ul> <p>The kit is ambidextrous and is therefore suitable for installation both on the right and left side of Steel Pro Power.</p>					1x		1x		1x	1x	1x	1x	1x	1x	1x	1x

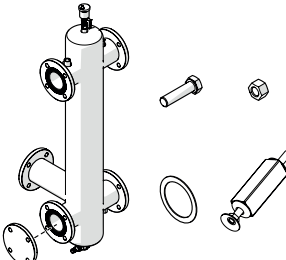
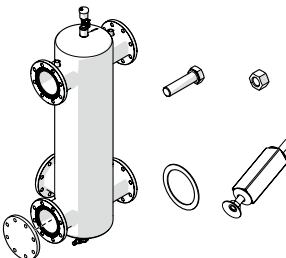
HYDRAULIC SEPARATORS/PLATE HEAT EXCHANGERS		STEEL PRO POWER															
	DESCRIPTION	114-2 P	140-2 P	180-2 P	230-2 P	270-2 P	300-3 P	345-3 P	405-3 P	460-4 P	540-4 P	SYSTEM 675	SYSTEM 810	SYSTEM 945	SYSTEM 1080	SYSTEM 1215	SYSTEM 1350
	<p><b>Hydraulic separator 3" connections (up to 485kW)</b> The kit, which can be installed up to a power of 485 kW, consists of:</p> <ul style="list-style-type: none"> <li>- hydraulic compensator with 5" diameter and 5 3" flanged connections;</li> <li>- insulation;</li> <li>- blind flange (to close the unused hydraulic connection);</li> <li>- support foot;</li> <li>- hose cock, automatic air vent valve and probe/thermostat holders;</li> <li>- gaskets and bolts for installation.</li> </ul> <p>The kit is ambidextrous and is therefore suitable for both left and right installations of Steel Pro Power.</p>	1x	1x	1x	1x	1x	1x	1x	1x	1x							
	<p><b>Hydraulic separator 5" connections (up to 1310kW)</b> The kit, which can be installed up to a power of 1310 kW, consists of:</p> <ul style="list-style-type: none"> <li>- 10" diameter hydraulic compensator and 5" flanged connections;</li> <li>- insulation;</li> <li>- blind flange (to close the unused hydraulic connection);</li> <li>- support foot;</li> <li>- hose cock, automatic air vent valve and probe/thermostat holders;</li> <li>- gaskets and bolts for installation.</li> </ul> <p>The kit is ambidextrous and is therefore suitable for both left and right installations of Steel Pro Power.</p>										1x	1x	1x	1x	1x	1x	1x

## CONDENSING GENERATORS

Indoor/Outdoor floor standing gas condensing modules

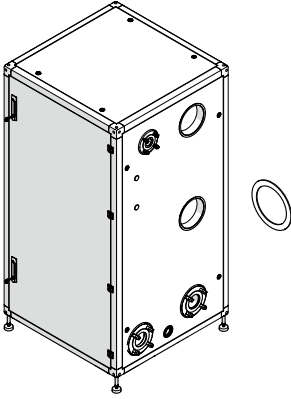
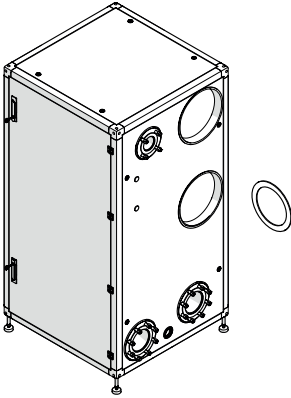
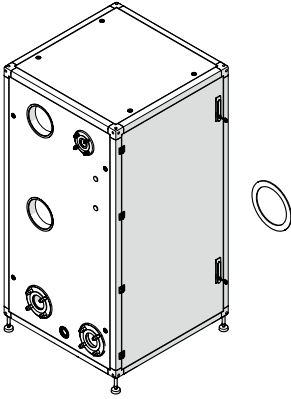
HYDRAULIC SEPARATORS/PLATE HEAT EXCHANGERS		STEEL PRO POWER																	
	DESCRIPTION	114-2 P	140-2 P	180-2 P	230-2 P	270-2 P	300-3 P	345-3 P	405-3 P	460-4 P	540-4 P	SYSTEM 675	SYSTEM 810	SYSTEM 945	SYSTEM 1080	SYSTEM 1215	SYSTEM 1350		
	<p><b>Left technical cabinet with hydraulic separator up to 485 kW.</b></p> <p>The technical cabinet is made up of the same cabinet that characterises the Steel Pro Power 2-module cabinets, but differs in content; it is designed to enclose the primary components and create an effect of visual continuity of the boiler and its accessories. With a special cover kit (accessory) it can also be installed outdoors. If desired, the cabinet can be used to install the extension of the flue gas and air collectors (both accessory kits) if the flue gas discharge and air intake are installed on the same side as the hydraulic connections. The pre-prepared connections are DN160. It contains the safety connection and the hydraulic compensator. The cabinet is 900 mm wide, with 3" flanged hydraulic connections DN80 - PN6, prepared to be installed on the left side of Steel Pro Power (with reference to the front view of the boiler).</p>	1x	1x	1x	1x	1x	1x	1x	1x	1x									
	<p><b>Left technical cabinet with hydraulic separator up to 1310 kW.</b></p> <p>The technical cabinet is made up of the same cabinet that characterises the Steel Pro Power 2-module cabinets, but it differs in its content; in fact, it is designed to enclose the primary components and create an effect of visual continuity of the boiler and its accessories. With a special cover kit (accessory) it can also be installed outdoors. If desired, the cabinet can be used to install the extension of the flue gas and air collectors (both accessory kits) if the flue gas discharge and air intake are installed on the same side as the hydraulic connections. The pre-prepared connections are DN300. It contains the safety connection and the hydraulic compensator. The cabinet is 900 mm wide, with 5" flanged hydraulic connections DN125 - PN6, prepared to be installed on the left side of Steel Pro Power (with reference to the front view of the boiler).</p>										1x	1x	1x	1x	1x	1x	1x	1x	
	<p><b>Right technical cabinet with hydraulic separator (up to 485 kW).</b></p> <p>The technical cabinet is made up of the same cabinet that characterises the Steel Pro Power 2-module cabinets, but it differs in its content; in fact, it is designed to enclose the primary components and create an effect of visual continuity of the boiler and its accessories. With a special cover kit (accessory) it can also be installed outdoors. If desired, the cabinet can be used to install the extension of the flue gas and air collectors (both accessory kits) if the flue gas discharge and air intake are installed on the same side as the hydraulic connections. The pre-prepared connections are DN160. It contains the safety connection and the hydraulic compensator. The cabinet is 900 mm wide, with 3" flanged hydraulic connections DN80 - PN6, prepared to be installed on the right side of Steel Pro Power (with reference to the front view of the boiler).</p>	1x	1x	1x	1x	1x	1x	1x	1x	1x									

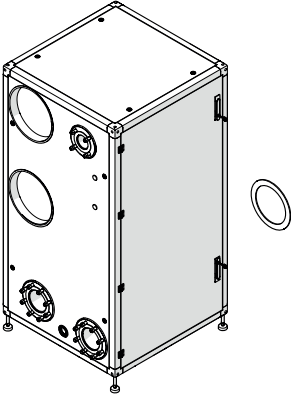
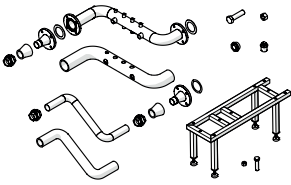
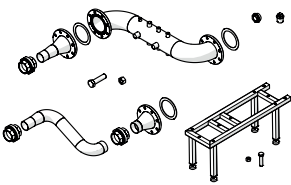
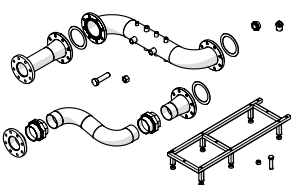
HYDRAULIC SEPARATORS/PLATE HEAT EXCHANGERS		STEEL PRO POWER															
	DESCRIPTION	114-2 P	140-2 P	180-2 P	230-2 P	270-2 P	300-3 P	345-3 P	405-3 P	460-4 P	540-4 P	SYSTEM 675	SYSTEM 810	SYSTEM 945	SYSTEM 1080	SYSTEM 1215	SYSTEM 1350
	<p><b>Right technical cabinet with hydraulic separator up to 1310 kW.</b> The technical cabinet is made up of the same cabinet that characterises the Steel Pro Power 2-module cabinets, but it differs, precisely, in its content; in fact, it is designed to enclose the primary components and create an effect of visual continuity of the boiler and its accessories. With a special cover kit (accessory) it can also be installed outdoors. If desired, the cabinet can be used to install the extension of the flue gas and air collectors (both accessory kits) if the flue gas discharge and air intake are installed on the same side as the hydraulic connections. The pre-prepared connections are DN300.</p> <p>It contains the safety connection and the hydraulic compensator. The cabinet is 900 mm wide, with 5" flanged hydraulic connections DN125 - PN6, prepared to be installed on the right side of Steel Pro Power (with reference to the front view of the boiler).</p>										1x	1x	1x	1x	1x	1x	1x
	<p><b>Connection kit for plate heat exchanger DN80/DN50</b> The kit allows to connect the safety connections to the inspectable plate exchangers of the HEATgate range, used for STAND ALONE models from 114 to 460 only in case of installation without technical cabinet.</p> <p>The kit consists of:</p> <ul style="list-style-type: none"> <li>- FE piping, flow and return, 3" DN80 - PN6 /2" DN50 (HEATgate, SP 35 plate family) connecting safety connections to the HEATgate range plate exchangers;</li> <li>- Thermal insulation;</li> <li>- Support frame for plate heat exchanger.</li> </ul>	1x	1x	1x	1x	1x	1x	1x	1x	1x							
	<p><b>Connection kit for plate heat exchanger DN125/DN65</b> The kit allows to connect the safety connections to the HEATgate inspectable plate exchangers, used for the 540 STAND ALONE model and for the 675 and 810 cascade models, only in case of installation without technical cabinet.</p> <p>The kit consists of:</p> <ul style="list-style-type: none"> <li>- FE piping, flow and return, 5" DN125 - PN6/2" 1/2 DN65 (HEATgate, SP 50 plate range) for connection between safety connections to the plate exchangers of the HEATgate range;</li> <li>- Thermal insulation;</li> <li>- Support frame for plate heat exchanger.</li> </ul>										1x	1x	1x				
	<p><b>Connection kit for plate heat exchanger DN125/DN100</b> The kit allows to connect the safety connections to the HEATgate inspectable plate exchangers, used for the cascade models 945, 1080, 1215 and 1350, only in case of installation without technical cabinet.</p> <p>The kit consists of:</p> <ul style="list-style-type: none"> <li>- FE piping, flow and return, 5" DN125 - PN6/4" DN100 (HEATgate, SP 60 plate range) connecting safety connections to the HEATgate range plate exchangers;</li> <li>- Thermal insulation;</li> <li>- Plate exchanger support frame.</li> </ul>													1x	1x	1x	1x

## CONDENSING GENERATORS

Indoor/Outdoor floor standing gas condensing modules

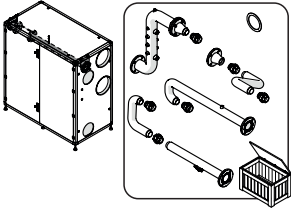
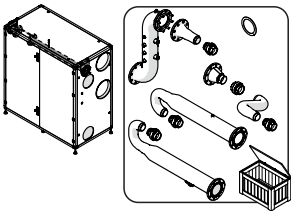
HYDRAULIC SEPARATORS/PLATE HEAT EXCHANGERS		STEEL PRO POWER																	
	DESCRIPTION	114-2 P	140-2 P	180-2 P	230-2 P	270-2 P	300-3 P	345-3 P	405-3 P	460-4 P	540-4 P	SYSTEM 675	SYSTEM 810	SYSTEM 945	SYSTEM 1080	SYSTEM 1215	SYSTEM 1350		
	<p><b>Left-side technical cabinet for plate heat exchanger (up to 485 kW)</b> The technical cabinet is made up of the same cabinet that characterises the 4-module Steel Pro Power cabinets, but differs in its content; it is in fact designed to enclose the primary components and create an effect of visual continuity of the boiler and its accessories. With a special cover kit (accessory) it can also be installed outdoors. If desired, the cabinet can be used to install the extension of the flue gas and air collectors (both accessory kits) if the flue gas discharge and air intake are installed on the same side as the hydraulic connections. The pre-prepared connections are DN160. It contains the safety connection, the plate heat exchanger connection kit but not the heat exchanger and its possible insulation kit. The cabinet is 1700 mm wide, with 3" flanged DN80 - PN6 hydraulic connections, designed to accept exchangers from the HEATgate range, SP 35 plate range. The cabinet is designed to be installed to the left of Steel Pro Power (with reference to the front view of the boiler).</p>	1x	1x	1x	1x	1x	1x	1x	1x	1x									
	<p><b>Left-side technical cabinet for plate heat exchanger (up to 800 kW)</b> The technical cabinet is made up of the same cabinet that characterises the 4-module Steel Pro Power cabinets, but it differs, precisely, in its content; in fact, it is designed to enclose the primary components and create an effect of visual continuity of the boiler and its accessories. With a special cover kit (accessory) it can also be installed outdoors. If desired, the cabinet can be used to install the extension of the flue gas and air collectors (both accessory kits) if the flue gas discharge and air intake are installed on the same side as the hydraulic connections. The pre-prepared connections are DN300. It contains the safety connection, the plate exchanger connection kit but not the exchanger and its possible insulation kit. The cabinet has a width of 1700 mm, with 5" flanged hydraulic connections DN125 - PN6 prepared to accept exchangers of the HEATgate range, SP 50 plate range. The cabinet is designed to be installed on the left side of Steel Pro Power (with reference to the front view of the boiler).</p>										1x	1x	1x						

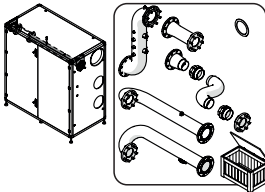
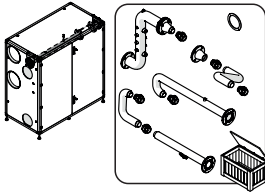
HYDRAULIC SEPARATORS/PLATE HEAT EXCHANGERS		STEEL PRO POWER															
	DESCRIPTION	114-2 P	140-2 P	180-2 P	230-2 P	270-2 P	300-3 P	345-3 P	405-3 P	460-4 P	540-4 P	SYSTEM 675	SYSTEM 810	SYSTEM 945	SYSTEM 1080	SYSTEM 1215	SYSTEM 1350
	<p><b>Left-side technical cabinet for plate heat exchanger (up to 1310 kW)</b></p> <p>The technical cabinet is made up of the same cabinet that characterises the 4-module Steel Pro Power cabinets, but differs in its content; it is in fact designed to enclose the primary components and create an effect of visual continuity of the boiler and its accessories. With a special cover kit (accessory) it can also be installed outdoors. If desired, the cabinet can be used to install the extension of the flue gas and air collectors (both accessory kits) if the flue gas discharge and air intake are installed on the same side as the hydraulic connections. The pre-prepared connections are DN300. It contains the safety connection, the plate heat exchanger connection kit but not the heat exchanger and its possible insulation kit. The cabinet has a width of 1700 mm, with 5" flanged hydraulic connections DN125 - PN6 prepared to accept exchangers of the HEATgate range, SP 60 plate range. The cabinet is designed to be installed on the left side of Steel Pro Power (with reference to the front view of the boiler).</p>													1x	1x	1x	1x
	<p><b>Right-side technical cabinet for plate heat exchanger (up to 485 kW)</b></p> <p>The technical cabinet is made up of the same cabinet that characterises the 4-module Steel Pro Power cabinets, but it differs in its content; in fact, it is designed to enclose the primary components and create an effect of visual continuity of the boiler and its accessories. With a special cover kit (accessory) it can also be installed outdoors. If desired, the cabinet can be used to install the extension of the flue gas and air collectors (both accessory kits) if the flue gas discharge and air intake are installed on the same side as the hydraulic connections. The pre-prepared connections are DN160. It contains the safety connection, the plate heat exchanger connection kit but not the heat exchanger and its possible insulation kit. The cabinet has a width of 1700 mm, with 3" flanged hydraulic connections DN80 - PN6 prepared to accept exchangers of the HEATgate range, SP 35 plate range. The cabinet is designed to be installed on the right side of Steel Pro Power (with reference to the front view of the boiler).</p>	1x	1x	1x	1x	1x	1x	1x	1x	1x							

## CONDENSING GENERATORS

Indoor/Outdoor floor standing gas condensing modules

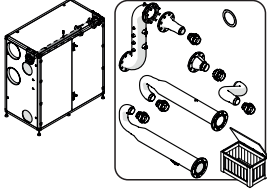
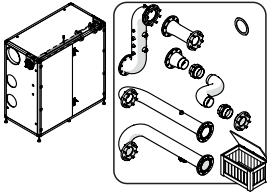
HYDRAULIC SEPARATORS/PLATE HEAT EXCHANGERS		STEEL PRO POWER																
	DESCRIPTION	114-2 P	140-2 P	180-2 P	230-2 P	270-2 P	300-3 P	345-3 P	405-3 P	460-4 P	540-4 P	SYSTEM 675	SYSTEM 810	SYSTEM 945	SYSTEM 1080	SYSTEM 1215	SYSTEM 1350	
	<p><b>Right-side technical cabinet for plate heat exchanger (up to 800 kW)</b> The technical cabinet is made up of the same cabinet that characterises the 4-module Steel Pro Power cabinets, but differs in content; it is in fact designed to enclose the primary components and create an effect of visual continuity of the boiler and its accessories. With a special cover kit (accessory) it can also be installed outdoors. If desired, the cabinet can be used to install the extension of the flue gas and air collectors (both accessory kits) if the flue gas discharge and air intake are installed on the same side as the hydraulic connections. The pre-prepared connections are DN300. It contains the safety connection, the plate heat exchanger connection kit but not the heat exchanger and its possible insulation kit. The cabinet has a width of 1700 mm, with 5" flanged hydraulic connections DN125 - PN6 prepared to accept exchangers of the HEATgate range, SP 50 plate range. The cabinet is designed to be installed on the right side of Steel Pro Power (with reference to the front view of the boiler).</p>										1x	1x	1X					
	<p><b>Right-side technical cabinet for plate heat exchanger (up to 1310 kW)</b> The technical cabinet is made up of the same cabinet that characterises the 4-module Steel Pro Power cabinets, but it differs in its content; in fact, it is designed to enclose the primary components and create an effect of visual continuity of the boiler and its accessories. With a special cover kit (accessory) it can also be installed outdoors. If desired, the cabinet can be used to install the extension of the flue gas and air collectors (both accessory kits) if the flue gas discharge and air intake are installed on the same side as the hydraulic connections. The pre-prepared connections are DN300. It contains the safety connection, the plate heat exchanger connection kit but not the heat exchanger and its possible insulation kit. The cabinet has a width of 1700 mm, with 5" flanged hydraulic connections DN125 - PN6 prepared to accept exchangers of the HEATgate range, SP 60 plate range. The cabinet is designed to be installed on the right side of Steel Pro Power (with reference to the front view of the boiler).</p>													1x	1x	1X	1x	

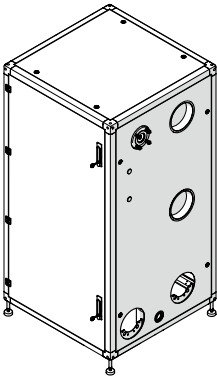
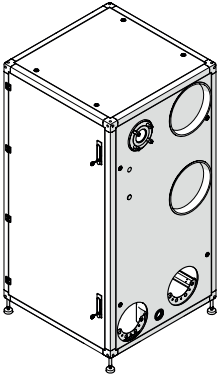
HYDRAULIC SEPARATORS/PLATE HEAT EXCHANGERS		STEEL PRO POWER																
	DESCRIPTION	114-2 P	140-2 P	180-2 P	230-2 P	270-2 P	300-3 P	345-3 P	405-3 P	460-4 P	540-4 P	SYSTEM 675	SYSTEM 810	SYSTEM 945	SYSTEM 1080	SYSTEM 1215	SYSTEM 1350	
	<p><b>Right/left technical cabinet for housing 3" extensions kit (up to 485 kW)</b></p> <p>The technical cabinet is made up of the same cabinet that characterises the Steel Pro Power 2-module cabinets, but differs in content; it is in fact designed to enclose the primary components and create an effect of visual continuity of the boiler and its accessories. With a special cover kit (accessory) it can also be installed outdoors. If desired, the cabinet can be used to install the extension of the flue gas and air collectors (both accessory kits) if the flue gas discharge and air intake are installed on the same side as the hydraulic connections. The pre-prepared connections are DN160. The 3" straight extension kit with safety wells and VIC valve (not supplied with the cabinet) can be housed inside. The cabinet has a width of 900 mm and is ambidextrous, therefore it is designed to be installed both on the left and on the right side of Steel Pro Power (with reference to the frontal view of the boiler).</p>	1x	1x	1x	1x	1x	1x	1x	1x	1x								
	<p><b>Right/left technical cabinet for 5" extensions kit (up to 1310 kW)</b></p> <p>The technical cabinet is made up of the same cabinet that characterises the Steel Pro Power 2-module cabinets, but it differs in its content; in fact, it is designed to enclose the primary components and create an effect of visual continuity of the boiler and its accessories. With a special cover kit (accessory) it can also be installed outdoors. If desired, the cabinet can be used to install the extension of the flue gas and air collectors (both accessory kits) if the flue gas discharge and air intake are installed on the same side as the hydraulic connections. The pre-prepared connections are DN300. The 5" straight extension kit with safety wells and VIC valve (not supplied with the cabinet) can be housed inside. The cabinet has a width of 900 mm and is ambidextrous, so it is designed to be installed both on the left and on the right side of Steel Pro Power (with reference to the frontal view of the boiler).</p>										1x	1x	1x	1x	1x	1x	1x	1x

## CONDENSING GENERATORS

Indoor/Outdoor floor standing gas condensing modules

### Plate heat exchanger combinations for boiler operation with different $\Delta t_{ml}$

Description			Plate heat exchangers			
Nr. of generators in cascade application	Model	Useful power kW	Heat exchanger model	DN	Heat exchanger model	DN
1	STEEL PRO POWER 114-2	114	SP 35-DN50 21 (21) N	Rp 2" (G-M)*	SP 35-DN50 33 (33) N	Rp 2" (G-M)*
	STEEL PRO POWER 140-2	136	SP 35-DN50 21 (21) N	Rp 2" (G-M)*	SP 35-DN50 33 (33) N	Rp 2" (G-M)*
	STEEL PRO POWER 180-2	180	SP 35-DN50 27 (27) N	Rp 2" (G-M)*	SP 35-DN50 49 (49) N	Rp 2" (G-M)*
	STEEL PRO POWER 230-2	224	SP 35-DN50 33 (33) N	Rp 2" (G-M)*	SP 35-DN50 53 (53) N	Rp 2" (G-M)*
	STEEL PRO POWER 270-2	262	SP 35-DN50 41 (41) N	Rp 2" (G-M)*	SP 35-DN50 61 (61) N	Rp 2" (G-M)*
	STEEL PRO POWER 300-3	291	SP 35-DN50 41 (41) N	Rp 2" (G-M)*	SP 35-DN50 71 (71) N	Rp 2" (G-M)*
	STEEL PRO POWER 345-3	336	SP 35-DN50 49 (49) N	Rp 2" (G-M)*	SP 35-DN50 81 (81) N	Rp 2" (G-M)*
	STEEL PRO POWER 405-3	393	SP 35-DN50 61 (61) N	Rp 2" (G-M)*	SP 35-DN50 89 (89) N	Rp 2" (G-M)*
	STEEL PRO POWER 460-4	448	SP 35-DN50 61 (61) N	Rp 2" (G-M)*	SP 35-DN50 101 (101) N	Rp 2" (G-M)*
	STEEL PRO POWER 540-4	524	SP 50-DN65 35 (14) N	Rp 2" 1/2 (G-M)*	SP 50-DN65 55 (22) N	Rp 2" 1/2 (G-M)*
2	STEEL PRO POWER SYSTEM 675	655	SP 50-DN65 45 (18) N	Rp 2" 1/2 (G-M)*	SP 50-DN65 65 (26) N	Rp 2" 1/2 (G-M)*
	STEEL PRO POWER SYSTEM 810	786	SP 50-DN65 51 (21) N	Rp 2" 1/2 (G-M)*	SP 50-DN65 79 (32) N	Rp 2" 1/2 (G-M)*
	STEEL PRO POWER SYSTEM 945	917	SP 60-DN100 45 (36) N	DN100 - PN16	SP 60-DN100 67 (54) N	DN100 - PN16
	STEEL PRO POWER SYSTEM 1080	1048	SP 60-DN100 51 (41) N	DN100 - PN16	SP 60-DN100 77 (62) N	DN100 - PN16
3	STEEL PRO POWER SYSTEM 1215	1179	SP 60-DN100 61 (49) N	DN100 - PN16	SP 60-DN100 87 (70) N	DN100 - PN16
	STEEL PRO POWER SYSTEM 1350	1310	SP 60-DN100 67 (54) N	DN100 - PN16	SP 60-DN100 97 (78) N	DN100 - PN16

(\*) G-M: Gas-M

### Plate heat exchanger combinations for boiler operation with a mixture of water and glycol (max 40%)\*\*

Description			Plate heat exchangers	
Nr. of generators in cascade application	Model	Useful power kW	Heat exchanger model	DN
1	STEEL PRO POWER 114-2	114	SP 45-DN50 21 (11) E	Rp 2" (G-M)*
	STEEL PRO POWER 140-2	136	SP 45-DN50 29 (15) E	Rp 2" (G-M)*
	STEEL PRO POWER 180-2	180	SP 45-DN50 29 (15) E	Rp 2" (G-M)*
	STEEL PRO POWER 230-2	224	SP 45-DN50 33 (17) E	Rp 2" (G-M)*
	STEEL PRO POWER 270-2	262	SP 45-DN50 39 (20) E	Rp 2" (G-M)*
	STEEL PRO POWER 300-3	291	SP 45-DN50 45 (23) E	Rp 2" (G-M)*
	STEEL PRO POWER 345-3	336	SP 45-DN50 51 (26) E	Rp 2" (G-M)*
	STEEL PRO POWER 405-3	393	SP 45-DN50 61 (31) E	Rp 2" (G-M)*
	STEEL PRO POWER 460-4	448	SP 45-DN50 73 (37) E	Rp 2" (G-M)*
	STEEL PRO POWER 540-4	524	SP 50-DN65 69 (52) E	Rp 2" 1/2 (G-M)*
2	STEEL PRO POWER SYSTEM 675	655	SP 50-DN65 87 (66) E	Rp 2" 1/2 (G-M)*
	STEEL PRO POWER SYSTEM 810	786	SP 50-DN65 101 (76) E	Rp 2" 1/2 (G-M)*
	STEEL PRO POWER SYSTEM 945	917	SP 60-DN100 87 (87) E	DN100 - PN16
	STEEL PRO POWER SYSTEM 1080	1048	SP 60-DN100 101 (101) E	DN100 - PN16
3	STEEL PRO POWER SYSTEM 1215	1179	SP 60-DN100 115 (115) E	DN100 - PN16
	STEEL PRO POWER SYSTEM 1350	1310	SP 60-DN100 129 (129) E	DN100 - PN16

(\*) G-M: Gas-M

(\*\*) Not compatible with containment cabinets

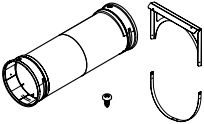
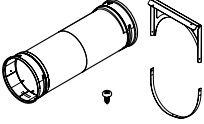
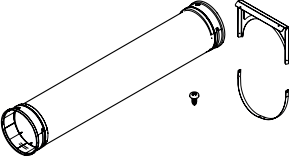
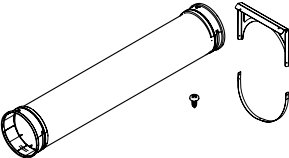
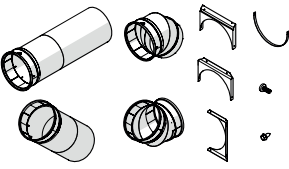
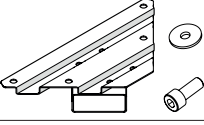
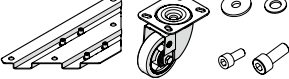
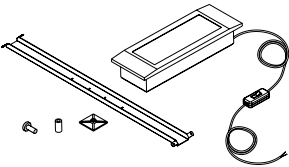
ADDITIONAL ACCESSORIES FOR TECHNICAL CABINETS (to be used as indicated in the tables on the following page)		
	DESCRIPTION	REF.
	<b>Air/exhaust collector technical cabinet L = 900 mm Ø160 mm</b> PP suction/exhaust collector kit to be installed in technical cabinet DN160 L = 906 mm (technical cabinet for safety extension kits and/or hydraulic separators) to be installed with versions 114 to 405 (except 270 and 405).	<b>Acc. 01</b>
	<b>Air/exhaust collector technical cabinet L = 900 mm Ø300 mm</b> PP suction/exhaust collector kit to be installed in technical cabinet DN300 L = 906 mm (technical cabinet for safety extension kits and/or hydraulic separators) to be installed with version 540 and all cascades.	<b>Acc. 02</b>
	<b>Air/exhaust collector technical cabinet L = 1800 mm Ø160 mm</b> PP air/exhaust collector kit to be installed in technical cabinet DN160 L = 1710 mm (technical cabinet for heat exchangers) to be installed with versions 114 to 460 (except 270 and 405).	<b>Acc. 03</b>
	<b>Air/exhaust collector technical cabinet L = 1800 mm Ø300 mm</b> PP suction/exhaust collector kit to be installed in technical cabinet DN300 L = 1710 mm (technical cabinet for heat exchangers) installable with STAND ALONE 540 version and with 675 and 810 cascades.	<b>Acc. 04</b>
	<b>5" collector flue gas technical cabinet L = 1800 mm Ø300 mm (SP60-DN100)</b> PP exhaust collector kit to be installed in technical cabinet DN300 L = 1710 mm (technical cabinet for heat exchangers) installable with 945, 1080, 1215 and 1350 cascades.	<b>Acc. 05</b>
	<b>Top lifting kit (to be used during installation)</b> The kit consists of shaped corner brackets to be installed underneath the heater/technical cabinet (at the 4 corners) to allow the lifting straps to pass through (and keep "in guide").	
	<b>Wheels kit (to be used during installation)</b> The kit consists of corner brackets with wheels to be installed underneath the generator/technical cabinet (at the 4 corners) to allow movement of the generator/cabinet during installation.	
	<b>Internal light kit for emergency and service</b> The kit allows the installation of a ceiling light with LED light to facilitate maintenance operations inside the cabinet. The light also acts as an emergency lamp.	

## CONDENSING GENERATORS

Indoor/Outdoor floor standing gas condensing modules

### OPEN CHAMBER BOILER CONFIGURATION

SELECTION TABLE	Exhaust flue side	Technical box side
TABLE A	Right	Right
	Left	Left
Collettori non necessari	Left	Right
	Right	Left

### ROOM SEALED BOILER CONFIGURATION

SELECTION TABLE	Exhaust flue side	Air suction side	Technical box side
TABLE A	Right	Right	Right
	Left	Left	Left
TABLE B	Left	Right	Right
	Left	Right	Left
	Right	Left	Right
	Right	Left	Left
Not necessary Collectors	Left	Left	Right
	Right	Right	Left

### LEFT SIDE CONFIGURATION

Technical box for hydraulic separator

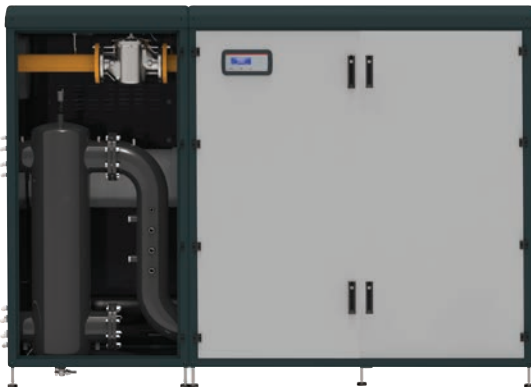

Technical box for plate heat exchanger

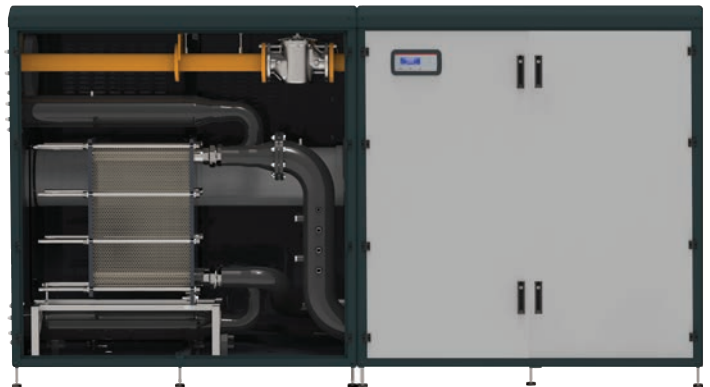

### RIGHT SIDE CONFIGURATION

Technical box for hydraulic separator

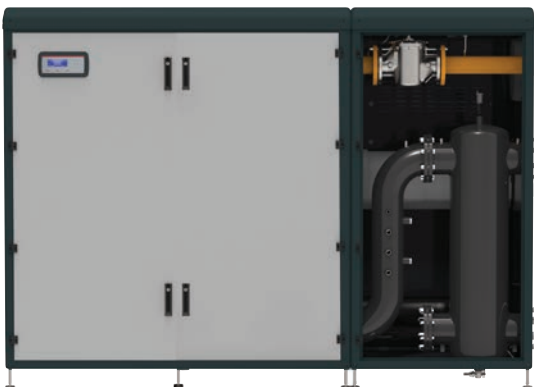

Technical box for plate heat exchanger

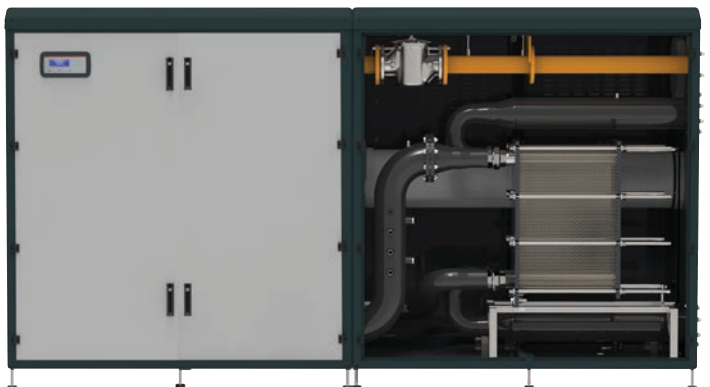

TABLE A

Code and number of the air/flue manifold	Technical box for extension housing or empty technical box				Technical box for hydraulic separator				Technical box for heat exchanger					
	Open chamber		Room sealed		Open chamber		Room sealed		Open chamber			Room sealed		
	Acc. 01	Acc. 02	Acc. 01	Acc. 02	Acc. 01	Acc. 02	Acc. 01	Acc. 02	Acc. 03	Acc. 04	Acc. 05	Acc. 03	Acc. 04	Acc. 05
STEEL PRO POWER 114-2 P	1x		2x		1x		2x		1x			2x		
STEEL PRO POWER 140-2 P	1x		2x		1x		2x		1x			2x		
STEEL PRO POWER 180-2 P	1x		2x		1x		2x		1x			2x		
STEEL PRO POWER 230-2 P	1x		2x		1x		2x		1x			2x		
STEEL PRO POWER 270-2 P (*)	1x				1x				1x					
STEEL PRO POWER 300-3 P	1x		2x		1x		2x		1x			2x		
STEEL PRO POWER 345-3 P	1x		2x		1x		2x		1x			2x		
STEEL PRO POWER 405-3 P (*)	1x				1x				1x					
STEEL PRO POWER 460-4 P	1x		2x		1x		2x		1x			2x		
STEEL PRO POWER 540-4 P		1x		2x		1x		2x		1x			2x	
STEEL PRO POWER SYSTEM 675		1x		2x		1x		2x		1x			2x	
STEEL PRO POWER SYSTEM 810		1x		2x		1x		2x		1x			2x	
STEEL PRO POWER SYSTEM 945		1x		2x		1x		2x			1x			(**)
STEEL PRO POWER SYSTEM 1080		1x		2x		1x		2x			1x			(**)
STEEL PRO POWER SYSTEM 1215		1x		2x		1x		2x			1x			(**)
STEEL PRO POWER SYSTEM 1350		1x		2x		1x		2x			1x			(**)

NOTE: to be used only if the flue gas outlet side is the same as the hydraulic outlet side.

(\*) Flue discharge/ air intake on the technical box side not available in case of sealed chamber, the air intake is mandatory on the boiler side.



(\*\*) In case of a technical box with plate heat exchanger and sealed installation, the air intake must take place on the boiler side and not on the technical box side. In this case also for the pump technical box, if present, is necessary to adopt only one code Acc. 02.

TABLE B

Code and number of the air/flue manifold	Technical box for extension housing or empty technical box				Technical box for hydraulic separator				Technical box for heat exchanger					
	Open chamber		Room sealed		Open chamber		Room sealed		Open chamber			Room sealed		
	Acc. 01	Acc. 02	Acc. 01	Acc. 02	Acc. 01	Acc. 02	Acc. 01	Acc. 02	Acc. 03	Acc. 04	Acc. 05	Acc. 03	Acc. 04	Acc. 05
STEEL PRO POWER 114-2 P	1x		1x		1x		1x		1x			1x		
STEEL PRO POWER 140-2 P	1x		1x		1x		1x		1x			1x		
STEEL PRO POWER 180-2 P	1x		1x		1x		1x		1x			1x		
STEEL PRO POWER 230-2 P	1x		1x		1x		1x		1x			1x		
STEEL PRO POWER 270-2 P	1x		1x		1x		1x		1x			1x		
STEEL PRO POWER 300-3 P	1x		1x		1x		1x		1x			1x		
STEEL PRO POWER 345-3 P	1x		1x		1x		1x		1x			1x		
STEEL PRO POWER 405-3 P	1x		1x		1x		1x		1x			1x		
STEEL PRO POWER 460-4 P	1x		1x		1x		1x		1x			1x		
STEEL PRO POWER 540-4 P		1x		1x		1x		1x		1x			1x	
STEEL PRO POWER SYSTEM 675		1x		1x		1x		1x		1x			1x	
STEEL PRO POWER SYSTEM 810		1x		1x		1x		1x		1x			1x	
STEEL PRO POWER SYSTEM 945		1x		1x		1x		1x			1x			1x
STEEL PRO POWER SYSTEM 1080		1x		1x		1x		1x			1x			1x
STEEL PRO POWER SYSTEM 1215		1x		1x		1x		1x			1x			1x
STEEL PRO POWER SYSTEM 1350		1x		1x		1x		1x			1x			1x

## CONDENSING GENERATORS

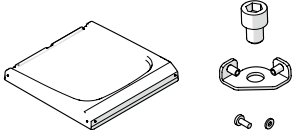
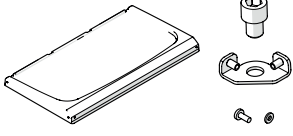
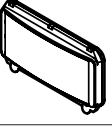
Indoor/Outdoor floor standing gas condensing modules

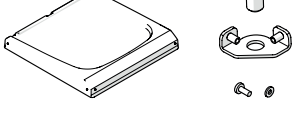
ADDITIONAL ACCESSORIES FOR OUTDOOR INSTALLATION																
DESCRIPTION	STEEL PRO POWER															
	114-2 P	140-2 P	180-2 P	230-2 P	270-2 P	300-3 P	345-3 P	405-3 P	460-4 P	540-4 P	SYSTEM 675	SYSTEM 810	SYSTEM 945	SYSTEM 1080	SYSTEM 1215	SYSTEM 1350
<b>CONFIGURATION WITH TECHNICAL CABINET FOR HYDRAULIC SEPARATOR OR EMPTY TECHNICAL CABINET</b>																
 <p><b>Roof kit for outdoor installation (cabinet L = 900 mm)</b> The kit consists of a L 900mm roof made of moulded anti-ageing ABS, UV resistant and allows the outdoor installation of Steel Pro Power 114 to 270 cabinets and primary circuit technical cabinets (for housing circulators or hydraulic separators). The kit must be combined with the IPX5D kit for display cover (accessory), in order to make the generator suitable for outdoor installation with electrical protection degree IPX5D.</p>	2x	2x	2x	2x	2x	1x	1x	1x	1x	1x	2x	2x	1x	1x	2x	2x
 <p><b>Roof kit for outdoor installation (cabinet L = 1700 mm)</b> The kit consists of a L 1800mm roof made of moulded anti-ageing ABS, UV resistant and allows the outdoor installation of Steel Pro Power cabinets from 300 to 540 and technical cabinets for primary circuit (for housing circulators or hydraulic separators). The kit must be combined with the IPX5D kit for display cover (accessory), in order to make the generator suitable for open-air installation with IPX5D electrical protection degree.</p>						1x	1x	1x	1x	1x	1x	1x	2x	2x	2x	2x
 <p><b>IPX5D display cover kit</b> The kit is designed to cover the display and protect it from rain and atmospheric events, making the boiler suitable for outdoor installation and raising the electrical protection rating to IPX5D.</p>	1x	1x	1x	1x	1x	1x	1x	1x	1x	1x	2x	2x	2x	2x	3x	3x
 <p><b>Outdoor insulation kit for 3" blind flanges</b> Insulation kit for outdoor installation (but also advisable in central heating installations), for covering blind flanges. It can be installed on models 114, 140, 180, 230, 300, 345, 460. The kit consists of: - 2 insulations for 3" blind flanges (hydraulic connections); - insulation for 2" blind flange (gas connection).</p>	1x	1x	1x	1x		1x	1x		1x							
 <p><b>Outdoor insulation kit for 5" blind flanges</b> Insulation kit for outdoor use (but also advisable in central heating installations), for covering blind flanges. It can be installed on models 270, 405 and 540. The kit consists of: - 2 insulations for 5" blind flanges (hydraulic connections); - insulation for 3" blind flange (gas connection).</p>					1x		1x		1x	1x	1x	1x	1x	1x	1x	1x
<b>CONFIGURATION WITH TECHNICAL CABINET FOR PLATE HEAT EXCHANGER</b>																
 <p><b>Roof kit for outdoor installation (cabinet L = 900 mm)</b> The kit consists of a 900mm long roof made made of moulded anti-ageing ABS, UV resistant and allows the outdoor installation of Steel Pro Power 114 to 270 cabinets and primary circuit technical cabinets (for housing circulators or hydraulic separators). The kit must be combined with the IPX5D kit for display cover (accessory) to make the generator suitable for open-air installation with IPX5D electrical protection rating.</p>	1x	1x	1x	1x	1x						1x	1x			1x	1x

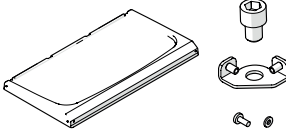
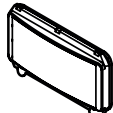
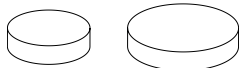
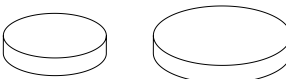
ADDITIONAL ACCESSORIES FOR OUTDOOR INSTALLATION		STEEL PRO POWER															
	DESCRIPTION	114-2 P	140-2 P	180-2 P	230-2 P	270-2 P	300-3 P	345-3 P	405-3 P	460-4 P	540-4 P	SYSTEM 675	SYSTEM 810	SYSTEM 945	SYSTEM 1080	SYSTEM 1215	SYSTEM 1350
	<b>Roof kit for outdoor installation (cabinet L = 1700 mm)</b> The kit consists of a 1800mm long roof made of moulded anti-aging ABS, UV resistant and allows the outdoor installation of Steel Pro Power 300 to 540 cabinets and primary circuit technical cabinets (for housing circulators or hydraulic separators). The kit must be combined with the IPX5D kit for display cover (accessory) to make the generator suitable for open-air installation with IPX5D electrical protection rating.	1x	1x	1x	1x	1x	2x	2x	2x	2x	2x	2x	2x	3x	3x	3x	3x
	<b>IPX5D display cover kit</b> The kit is designed to cover the display and protect it from rain and atmospheric events, making the boiler suitable for outdoor installation and raising the electrical protection rating to IPX5D.	1x	1x	1x	1x	1x	1x	1x	1x	1x	1x	2x	2x	2x	2x	3x	3x
	<b>Outdoor insulation kit for 3" blind flanges</b> Insulation kit for outdoor installation (but also advisable in central heating installations), for covering blind flanges. It can be installed on models 114, 140, 180, 230, 300, 345, 460. The kit consists of: - 2 insulations for 3" blind flanges (hydraulic connections); - insulation for 2" blind flange (gas connection).	1x	1x	1x	1x		1x	1x		1x							
	<b>Outdoor insulation kit for 5" blind flanges</b> Insulation kit for outdoor use (but also advisable in central heating installations), for covering blind flanges. It can be installed on models 270, 405 and 540. The kit consists of: - 2 insulations for 5" blind flanges (hydraulic connections); - insulation for 3" blind flange (gas connection).					1x			1x		1x	1x	1x	1x	1x	1x	1x

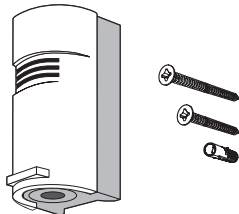
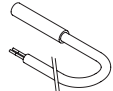
ACCESSORIES FOR SECONDARY CIRCUIT MANAGEMENT		STEEL PRO POWER															
	DESCRIPTION	114-2 P	140-2 P	180-2 P	230-2 P	270-2 P	300-3 P	345-3 P	405-3 P	460-4 P	540-4 P	SYSTEM 675	SYSTEM 810	SYSTEM 945	SYSTEM 1080	SYSTEM 1215	SYSTEM 1350
	<b>Outdoor sensor</b> Outdoor air sensor for Thermal Modules 35÷135 ( 50 P DEP÷150) models. Connecting the sensor to the boiler enables operation with climatic logic; the boiler flow temperature value is calculated by the control adapting to the climatic variations outside the building. The correct positioning of the outdoor sensor is fundamental for the correct operation of the climatic control; it must be installed on the NORTH or NORTH-WEST side of the building.	1x	1x	1x	1x	1x	1x	1x	1x	1x	1x	1x	1x	1x	1x	1x	1x
	<b>Immersion sensor</b> Used for secondary and tank management.	1x	1x	1x	1x	1x	1x	1x	1x	1x	1x	1x	1x	1x	1x	1x	1x

## CONDENSING GENERATORS

Indoor/Outdoor floor standing gas condensing modules

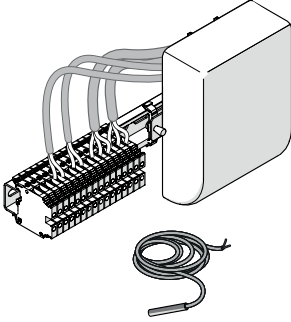
ACCESSORIES FOR SECONDARY CIRCUIT MANAGEMENT		STEEL PRO POWER																
	DESCRIPTION	114-2 P	140-2 P	180-2 P	230-2 P	270-2 P	300-3 P	345-3 P	405-3 P	460-4 P	540-4 P	SYSTEM 675	SYSTEM 810	SYSTEM 945	SYSTEM 1080	SYSTEM 1215	SYSTEM 1350	
	<p><b>Electronic kit for management of additional direct or mixed zone (max 16)</b> Kit for management of additional direct or mixed heating zone. It consists of an electronic control device fully wired to the terminal board, both installed on a DIN bar so as to allow installation inside control panel boxes. The electronic module is connected to the boiler board by means of a communication bus and allows management of the controlled zone with a dedicated climatic curve. Features: - Control of direct or mixed zone - Piloting of 3-point or STEP mixing valves - Zone circulation pump control - Input for TA or OT sensor.</p>	•	•	•	•	•	•	•	•	•	•	•	•	•	•	•	•	•

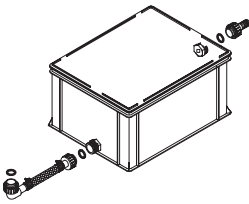
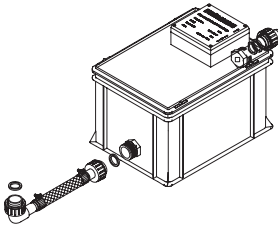
TREATMENT SYSTEMS FOR CONDENSATE NEUTRALISER		STEEL PRO POWER																	
	DESCRIPTION	114-2 P	140-2 P	180-2 P	230-2 P	270-2 P	300-3 P	345-3 P	405-3 P	460-4 P	540-4 P	SYSTEM 675	SYSTEM 810	SYSTEM 945	SYSTEM 1080	SYSTEM 1215	SYSTEM 1350		
	<p><b>N2 neutraliser kit (up to 450 kW)</b> Condensate neutraliser type N2 for gas condensing boilers up to 450 kW. The system allows to increase the pH of condensate deriving from the flue gas of condensing boilers to values between 6.5 and 9 to allow its disposal through the common sewer system. The kit is conceived for systems equipped with a condensate drain pit of the central heating plant placed lower than the condensate drain of the boiler and therefore having a natural slope. Therefore, they do not need a pump and related electrical connections.</p>	1x	1x	1x	1x	1x	1x	1x	1x	1x	2x	2x	2x	2x					
	<p><b>HN2 neutraliser kit (up to 270 kW)</b> Condensate neutraliser type HN2 for gas condensing boilers up to 270 kW. The system allows to increase the pH of condensate deriving from the flue gas of condensing boilers to values between 6.5 and 9 to allow its disposal through the common sewer system. The kit is suitable for those systems equipped with a central heating condensate drain placed higher than the boiler condensate drain. The maximum head that the pump can overcome is given by its maximum head minus the resistance offered by the discharge pipe. The pump is controlled by an electric level contact. The electrical connections have an electrical protection rating of IP54.</p>	1x	1x	1x	1x	1x	2x	2x	2x	2x	2x								

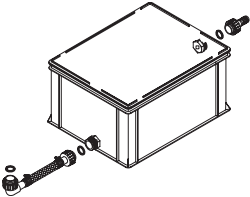
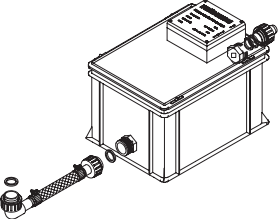
TREATMENT SYSTEMS FOR CONDENSATE NEUTRALISER																	
	DESCRIPTION	STEEL PRO POWER															
		114-2 P	140-2 P	180-2 P	230-2 P	270-2 P	300-3 P	345-3 P	405-3 P	460-4 P	540-4 P	SYSTEM 675	SYSTEM 810	SYSTEM 945	SYSTEM 1080	SYSTEM 1215	SYSTEM 1350
	<p><b>N3 neutraliser kit (450÷1500 kW)</b>            Condensate neutraliser type N3 for gas condensing boilers from 450 kW up to 1500 kW.            The system allows to increase the pH of the condensate deriving from the flue gas of condensing boilers to values between 6.5 and 9 to allow its disposal through the common sewer system.            The kit is conceived for systems equipped with a condensate drain pit of the central heating plant placed lower than the condensate drain of the boiler and therefore having a natural slope.            Therefore, they do not need a pump and related electrical connections.</p>										1x	1x	1x	1x	1x	1x	1x
	<p><b>HN3 neutraliser kit (270÷750 kW)</b>            Condensate neutraliser type HN3 for gas condensing boilers from 270 kW up to 750 kW.            The system allows to increase the pH of condensate deriving from the flue gas of condensing boilers to values between 6.5 and 9 to allow its disposal through the common sewer system.            The kit is suitable for those systems equipped with a central heating condensate drain placed higher than the boiler condensate drain.            The maximum head that the pump can overcome is given by its maximum head minus the resistance offered by the discharge pipe.            The pump is controlled by an electric level contact. The electrical connections have an electrical protection rating of IP54.</p>					1x	1x	1x	1x	1x	1x	2x	2x	2x	2x	2x	2x

## CONDENSING GENERATORS

Indoor/Outdoor floor standing gas condensing modules

### BOILER AND ACCESSORIES WATER CONTENT

STEEL PRO POWER MODELS	U.M.	300-3 P	345-3 P	405-3 P	460-4 P	540-4 P	300-3 P	345-3 P	405-3 P	460-4 P	540-4 P
Water content	l	45	45	50	60	75	80	100	120	120	150

STEEL PRO POWER SYSTEM CASCADE	U.M.	675 System	810 System	945 System	1080 System	1215 System	1350 System
Water content	l	195	240	270	300	345	375

ACCESSORY	U.M.	Water content
3" Flow safety kit	l	6,0
3" Return safety kit	l	4,0
5" Flow safety kit	l	14,3
5" Return safety kit	l	14,1
Hydraulic separator from 3" up to 485 kW	l	17,4
Hydraulic separator from 5" up to 1.310 kW	l	70,3
Fitting kit for plate heat exchanger DN80 (Ø3") / DN50	l	9,4
Fitting kit for plate heat exchanger DN125 (Ø5") / DN65	l	22,4
Fitting kit for plate heat exchanger DN125 (Ø5") / DN100	l	27,4

PLATE HEAT EXCHANGER RIELLO HEATGATE	U.M.	Primary water content
SP 35-DN50 21 (21) N	l	2,6
SP 35-DN50 27 (27) N	l	3,3
SP 35-DN50 33 (33) N	l	4,1
SP 35-DN50 41 (41) N	l	5,1
SP 35-DN50 49 (49) N	l	6,1
SP 35-DN50 53 (53) N	l	6,6
SP 35-DN50 61 (61) N	l	7,5
SP 35-DN50 71 (71) N	l	8,8
SP 35-DN50 81 (81) N	l	10,0
SP 35-DN50 89 (89) N	l	11,0
SP 35-DN50 101 (101) N	l	12,5
SP 45-DN50 21 (11) E	l	4,2
SP 45-DN50 29 (15) E	l	5,8
SP 45-DN50 33 (17) E	l	6,6
SP 45-DN50 39 (20) E	l	7,8
SP 45-DN50 45 (23) E	l	9,0
SP 45-DN50 51 (26) E	l	10,2
SP 45-DN50 61 (31) E	l	12,1
SP 45-DN50 73 (37) E	l	14,5
SP 50-DN65 35 (14) N	l	9,5
SP 50-DN65 45 (18) N	l	12,2
SP 50-DN65 51 (21) N	l	13,8
SP 50-DN65 55 (22) N	l	14,9
SP 50-DN65 65 (26) N	l	17,6
SP 50-DN65 79 (32) N	l	21,4
SP 50-DN65 69 (52) E	l	18,7
SP 50-DN65 87 (66) E	l	23,5
SP 50-DN65 101 (76) E	l	27,3
SP 60-DN100 45 (36) N	l	17,6
SP 60-DN100 51 (41) N	l	19,9
SP 60-DN100 61 (49) N	l	23,8
SP 60-DN100 67 (54) N	l	26,2
SP 60-DN100 77 (62) N	l	30,1
SP 60-DN100 87 (70) N	l	34,0
SP 60-DN100 97 (78) N	l	37,9
SP 60-DN100 87 (87) E	l	34,0
SP 60-DN100 101 (101) E	l	39,5
SP 60-DN100 115 (115) E	l	44,9
SP 60-DN100 129 (129) E	l	50,4

## ADDITIONAL SAFETY COMPONENTS

### SAFETY DEVICES KIT

The kit is composed of:

- Maximum pressure switch (characteristics shown in the table below)
- 0–10 bar pressure gauge with damper coil and tap
- Thermometer 0 –120°C

The safety / lock pressure switch (maximum pressure) meets the requirements of point 1.7 of the R File, Chap. R.2.B (2009 Edition) and point 10.3 of the R File Cap. R.1.B (2009 Edition) and has the following characteristics:

Model	PMR5
Type	Manual reset safety / block pressure switch (maximum pressure)
Maximum pressure	5 bar
Adjustment field	2,0 ÷ 4,5 bar
Calibration pressure (factory)	3,0 bar
Factory tolerance	± 0,15 bar
Ambient temperature range	55°C
Max. operating temperature	20°C to 110°C
Hydraulic connections	G 1/4" F

The remaining components are installed in the boiler and type-approved with it, in particular:

- Lock thermostat (calibrated at 95°C): installed on each thermal module
- Adjustment thermostat: consists in the climate control unit installed as standard on the boiler (control panel)
- Minimum pressure switch: installed on each thermal module (calibration pressure 0.7 bar)
- Flow-meter: automatically interrupts the heat input in case there is no circulation and is installed on the delivery of each thermal module

The kit must be completed with the safety valve (1 or 2 depending on the power of the generator) and with the fuel shut-off valve (separate accessories).

### SAFETY VALVE

The safety valves have the following characteristics:

- CE marking: the safety VST series valves meet the requirements of the Directive 97/23 / EC (PED) regarding pressure equipment. The valves fall into category IV, considered the maximum risk category since they are safety devices and bear the CE marking followed by the number 1115 which identifies the approval body.

Catalogue reference	up to 460 kW (3/4" F)	up to 580 kW (1" F)
Model	VST 20 3/4" x 1" 5.4 bar	VST 25 1" x 1" 1/4 5.4 bar
Body and cover	brass CW617N	brass CW617N
membrane and sealing gaskets	EPDM	EPDM
Nominal pressure	PN10	PN10
Overpressure	10%	10%
Closure deviation	< 20%	< 20%
Max. operating temperature	-10°C/+ 120°C	-10°C/+ 120°C
PED category	IV	IV
Hydraulic connections	3/4" F input / 1" F discharge	1" F input / 1" 1/4 F discharge
Opening pressure	5,4 bar	5,4 bar
Discharge pressure	5,94 bar	5,94 bar
Closing pressure	4,32 bar	4,32 bar
Discharge hole diameter	20 mm	25 mm
Discharge hole section	3.1416 cm <sup>2</sup>	4.9087 cm <sup>2</sup>
Discharge coefficient (K)	0.80	0.71
Discharge output	804,25 kg/h	1.120,24 kg/h
Generator nominal output	466,50 kW	649,79 kW

Total heat input of the cascade (kW)	0–460	461–580	581–920	921–1310
Quantity and type of the valve	1 x 460 kW (3/4" F)	1 x 580 kW (1" F)	2 x 460 kW (3/4" F)	2 x 580 kW (1" F) + 1 x 460 460 kW (3/4" F)

# CONDENSING GENERATORS

Indoor/Outdoor floor standing gas condensing modules

## FUEL SHUT-OFF VALVE (FSV)

The shut-off valves have the following characteristics:

Catalogue reference	ø G 1"	ø G 1" 1/2	ø G 2"	ø G 3"
Body	Die-cast aluminium			Molten aluminium
Temperature sensor	With liquid expansion			
Connections	Gas threaded FF (ISO 228/1)			
Pressure test points	2 of 1/4"			4 of 1/4"
Temperature sensor sheath connection	G 1/2" M (ISO 228/1)			Flanged PN16 (UNI 2223)
Calibration temperature	97°C (±3 °C)			
Sensor side max. temperature	120°C			
Valve side max. temperature	50°C			
Max operating pressure	6 bar		1 bar	
Reference	Recommended for maximum outputs of 131 kW (20 mbar gas supply)	Recommended for maximum outputs of 230 kW (20 mbar gas supply)	Recommended for maximum outputs of 580 kW (20 mbar gas supply)	Recommended for outputs up to 1310 kW (20 mbar gas supply)
DN	G 1" F	G 1" 1/2 F	G 2" F	DN80 - PN16
L [mm]	90	150	170	310
H [mm]	196	204	222	351
H1 [mm]	169	169	179	234
Capillary length [mm]	5000	5000	5000	5000

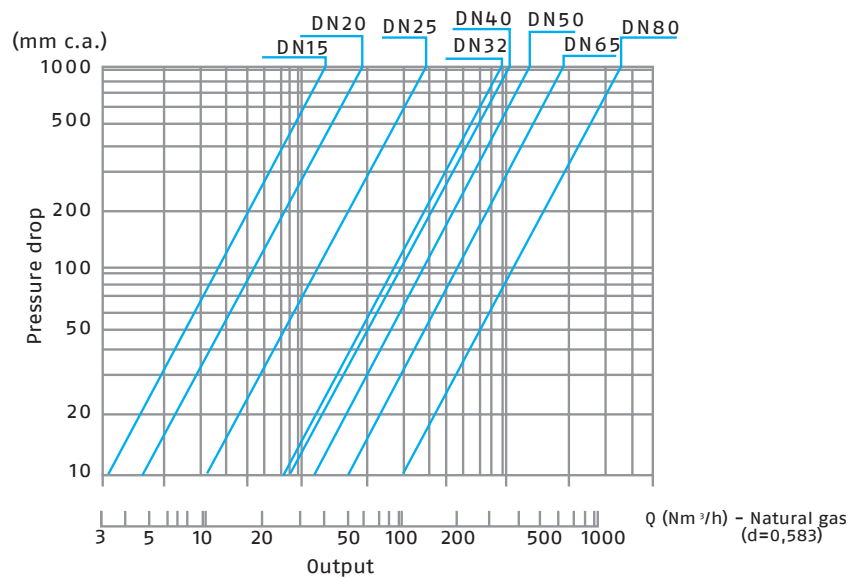
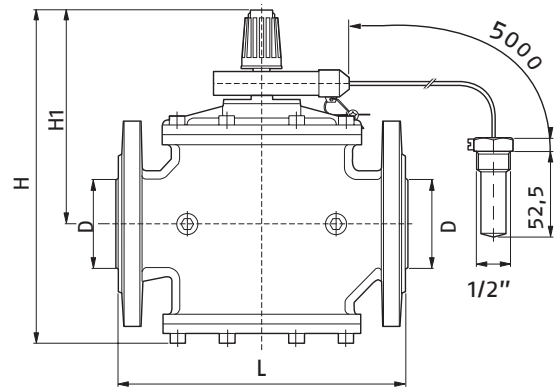
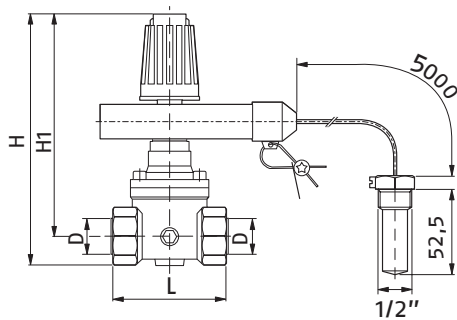

## ELECTRONIC ACCESSORIES

### BOILER REMOTE CONTROL KIT WITH 7" TOUCH SCREEN DISPLAY

The kit allows controlling remotely all the functions of the generator in a more convenient position for its supervision, through a 7" touch screen display.

### SECONDARY PROBE/STORAGE CYLINDER KIT

The kit is composed of 2 NTC immersion probes 10 kOhm at 25°C.

### DIRECT OR COMBINED ZONE MANAGEMENT ELECTRONIC KIT

The kit allows managing an additional zone with a dedicated climatic curve. It must be installed inside a system electrical panel or in a dedicated electric box. Once connected to the bus of the electronic control of the attached thermal module, it allows you to manage an additional zone or a mixed zone (for the electrical wiring see the combined system). It is possible to connect up to 16 zone management devices to the thermal module. In the event of a mixed zone the regulator controls the zone mixing valve and the circulator. In the event of an additional direct zone the regulator controls just the circulator of the zone.

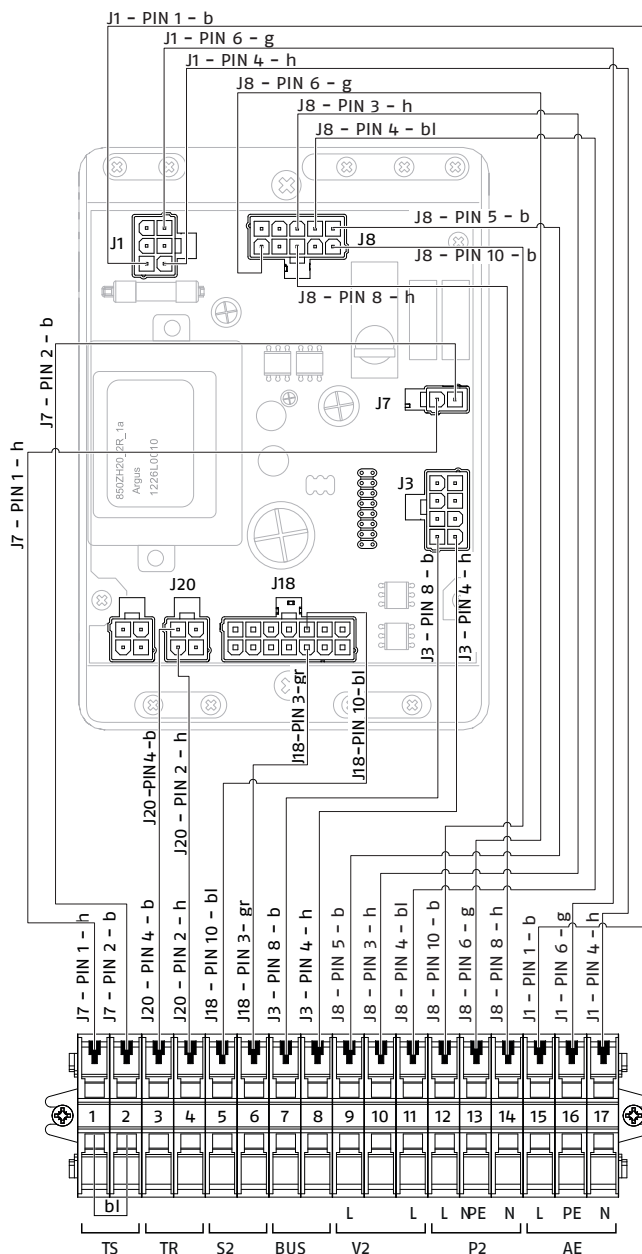
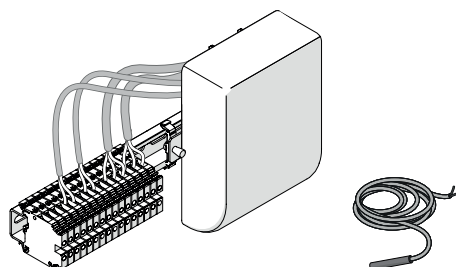

# CONDENSING GENERATORS

Indoor/Outdoor floor standing gas condensing modules

## ELECTRICAL CONNECTIONS

### MODULAR CONDENSING BOILER TERMINAL BOARD

**M01**  
Low-voltage terminal board

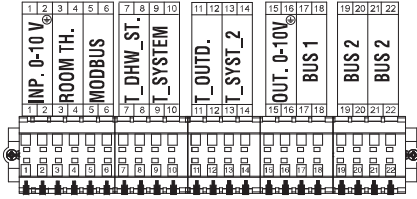

**M1D2**  
Low-voltage terminal board

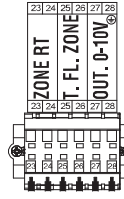

**M1D3**  
Low-voltage terminal board

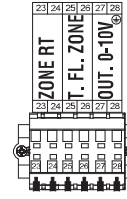

**M1D4**  
Low-voltage terminal board

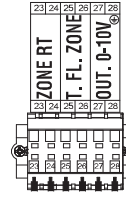

**M02**  
High-voltage terminal board

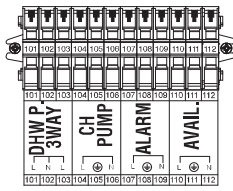

**M2D2**  
High-voltage terminal board

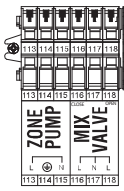

**M2D3**  
High-voltage terminal board

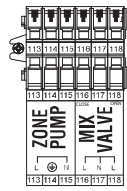

**M2D4**  
High-voltage terminal board

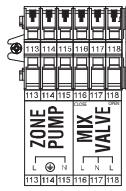

Terminal board key (MANAGING boiler)		
Terminal board	Contacts	Description
<b>M01</b> Low-voltage terminal board	<b>INP. 0-10V</b> (1-2)	Input 0-10V
	<b>ROOM TH.</b> (3-4)	Room thermostat - heat request (dry contact)
	<b>MODBUS</b> (5-6)	RS-485 line (ModBus RTU protocol)
	<b>T_DHW_ST.</b> (7-8)	DHW cylinder probe (accessory)
	<b>T_SYSTEM</b> (9-10)	System probe - primary or secondary circuit (mandatory accessory for cascades)
	<b>T_OUTD.</b> (11-12)	External sensor (accessory)
	<b>T_SYST_2</b> (13-14)	System sensor - primary or secondary circuit (mandatory accessory for waterfalls)
	<b>OUT. 0-10V</b> (14-15)	0-10V output
	<b>BUS 1</b> (16-17)	ArgusLink bus line used for cascades
<b>BUS 2</b> (18-19)-(20-21)	ArgusLink bus line used for cascades	
<b>M02</b> High-voltage terminal board	<b>DHW P. 3WAY</b> (101-102-103)	Cylinder circulator \ 3-way DHW valve
	<b>CH PUMP</b> (104-105-106)	System circulator (1-230V/50Hz)
	<b>ALARM</b> (107-108-109)	Alarm output (triac 1-230V/50Hz) - connect a load \ relay
	<b>AVAIL.</b> (110-111-112)	High voltage output for accessories connection

Terminal board key (DEPENDING boiler/boilers)		
Terminal board	Contacts	Description
<b>M1D2(3/4)</b> Low-voltage terminal board	<b>ZONE RT</b> (23-24)	Zone room thermostat - heat demand (potential-free contact)
	<b>T. FL. ZONE</b> (25-26)	Flow temperature sensor (zone)
	<b>OUT. 0-10V</b> (27-28)	0-10V output
<b>M2D2(3/4)</b> High-voltage terminal board	<b>ZONE PUMP</b> (113-114-115)	Zone system circulator (1-230V/50Hz)
	<b>MIX VALVE</b> (116-117-118)	Zone mixing valve (1-230V/50Hz)

## DESCRIPTION FOR SPECIFICATIONS

### PRODUCT DESCRIPTION FOR SPECIFICATIONS SUMMARY

STEEL PRO POWER is a heat generator composed of a cabinet (which can be installed in an internal thermal power station, or outdoors with an optional kit) that contains 2, 3 or 4 premixed and modulating thermal modules, with powers from 57 kW up to 131 kW per each furnace, with a total cabinet output ranging from 114 kW to 524 kW per furnace.

The range is divided into 10 power sizes, each of which offered either with injection circulators ("P").

The optimal combustion management supports high yields, over 109% (value calculated over NVC), with condensation, and low polluting emissions - Class 6 pursuant to UNI EN 15502-1.

STEEL PRO POWER can aspirate the air for combustion directly into the installation room or (through appropriate accessories) can be completely sealed.

The appliance in a standard configuration is designed for indoor installation to guarantee an IPX4D protection level. The appliance may also be installed outdoors by fitting special accessories that raise its electric protection to the IPX5D degree.

STEEL PRO POWER can be used either in stand-alone mode (single cabinet) or in cascade mode (several cabinet) up to a maximum capacity of 1.31 MW per furnace.

### PRODUCT DESCRIPTION FOR SPECIFICATIONS

STEEL PRO POWER is a heat generator composed of a cabinet (which can be installed in an internal thermal power station, or outdoors with an optional kit) that contains 2, 3 or 4 pre-mixed and modulating thermal modules, with outputs from 57 kW up to 131 kW per each furnace, with a total cabinet output ranging from 114kW to 524 kW per furnace.

The range is divided into 10 power sizes, each of which offered either with injection circulators ("P") or with 2-way valves ("V").

The optimal combustion management supports high yields, over 109% (value calculated over NVC), with condensation, and low polluting emissions - Class 6 pursuant to UNI EN 15502-1.

STEEL PRO POWER can aspirate the air for combustion directly into the installation room or (through appropriate accessories) can be completely sealed.

The appliance in a standard configuration is designed for indoor installation to guarantee an IPX4D protection level. The appliance may also be installed outdoors by fitting special accessories that raise its electric protection to the IPX5D degree.

Steel pro power can be used either in "stand alone" mode (single boiler) or in cascade mode, until reaching the maximum power of 1.31 mW per furnace.

The main technical characteristics of the appliance are:

- Containment cabinet composed of:
  - Robust frame, made of "Anticorodal" aluminium drawn support tails AW 6060 joined through penetrating tripod joint, weather resistant (suitable for both indoor and outdoor installation), saltiness and aggressive marine environments
  - Aluminate and painted metal sheet panels for maximum resistance to outdoor installation, salinity and aggressive marine environments
  - Internal insulation to guarantee reduced casing losses and high thermal efficiency, made of high density open-cell expanded polyurethane resin with high insulating power (both thermal and acoustic), impermeable to water and oils and self-adhesive
  - Support legs and height adjustment, sized to support the weight of the generators and accessories installed inside the cabinet
  - Door (configuration with 2 modules) / doors (configuration with 3 and 4 modules) equipped with robust hinges that are weather resistant and UV rays resistant, with retractable handles (to prevent injury from protruding bodies) with lock (to prevent tampering and ensure the safety). The internal side of the door supports the electrical panel containing the boiler boards
  - High volume that allows housing the thermal modules, the gas valves, the water manifolds, the gas manifold, the flue gas and air manifolds and air manifolds (the latter is accessory) to protect them against UV rays
- Condensing modules consisting of:
  - Heat exchangers with patented geometries (PATENT OWNED BY RIELLO) characterised by:
  - Double acting helical structure to reduce pressure drops and increase the exchange surface, consisting of two plain stainless steel austenitic (316L) pipes, with pentagonal section inside and circular outside, designed to maximize the exchange surface, offer maximum resistance to corrosion and the possibility of working with high  $\Delta T$  (up to 40 ° C) reducing the time needed for reaching the steady state
  - Water cooled heads to increase yields, which act as a connecting / balancing manifold between the two pipes that make up the exchanger
  - Retarder inside the heat exchanger that allows the flue gases, pushed by the fan, to cross the diffuser discs consisting of the two side-by-side coils forming, in fact, two distinct chambers inside the heat exchanger and increasing the condensation and the average seasonal yield
  - Output of each 57 kW, 68 kW, 90 kW, 97 kW, 112 kW and 131 kW module at the furnace
  - Very high yields up to more than 109% in condensing mode (50-30°C)
  - Maximum flue gases output temperature 78°C (at maximum output and high temperature) and very low flue gas-water  $\Delta t$  (containing up to 1°C)
  - Flue gas exhaust made of plastic material, resistant to UV rays, equipped with check valve to avoid the combustion products reflux
  - Maximum operating pressure 6 bar.
- Total pre-mixing burner characterized by:
  - Stainless steel combustion head operating with micro-flames to obtain very low NOx values (Class 6 according to UNI EN 15502-1) and CO values
  - Continuous fan modulation with very low energy consumption (modulation range up to 1:5)
  - High discharge head fan to facilitate the discharge of the flue gases under pressure

## CONDENSING GENERATORS

### Indoor/Outdoor floor standing gas condensing modules

- Fan safety achieved by a Hall effect tachometer device so that the rotation speed is always monitored
- Pneumatic gas valve with high modulation ratio designed for "type C" operation with air pressure test point
- Gas tap
- Operation ensuring full safety and very low gas supply pressures
- Operation with a constant CO<sub>2</sub> percentage value in the flue gases throughout the modulation range
- Flame ignition and detection electrode
- LPG conversion kit supplied
- Preparation for the conversion of the boiler to "type C" (with the dedicated accessory)
- internal hydraulics consisting of:
  - Flanged and insulated delivery and return manifolds
  - Bleeding of the each module, equipped on the return pipe with a two-way gate valve to facilitate maintenance; a check valve is mounted on the same pipe
  - Flow-meter to control of the water circulation of each module
  - Minimum pressure switch to monitor the circuit pressure (minimum pressure 0.7 bar)
  - Manifold (located on the delivery pipes of each thermal module) prepared for the installation of a 3-way gate valve (with exhaust to atmosphere) and CE safety valve (train available as an accessory)
  - High efficiency circulator and high residual discharge head, controlled by PWM to guarantee constant  $\Delta T$  between delivery and return
- Control interface and electronics characterised by:
  - Anti-freeze mode
  - Outdoor temperature sensor that enables the climatic control function
  - Pre-fitting for room thermostat / heat request for the heating zones
  - Option to manage a direct heating circuit and a domestic hot water circuit with storage tank (either circulator or 3-way valve)
  - Option to manage up to 16 additional heating zones (mixed or direct) by means of an appropriate electronic expansion (accessory), each with a dedicated and independent climatic curve

The main functions of STEEL PRO POWER are the following:

- Date and time setting
- Setting heating system with 5 modes:
  - Operation with room thermostat/heat request and fixed set-point;
  - Operation with room thermostat/heat request and variable set-point depending on the outdoor temperature;
  - Climatic operation with attenuation controlled by room thermostat/heat request)
  - Continuous fixed set-point operation with attenuation controlled by room thermostat/heat request;
  - Set-point adjustment based on a 0-10V analogue input
- Setting DHW production in 3 modes:
  - No production of domestic hot water
  - Domestic hot water production with storage tank controlled by a storage cylinder probe
  - Domestic hot water production with storage tank controlled by a thermostat
- Anti-legionella function
- DHW-heating priority setting
  - On: priority allocated to the DHW circuit
  - Off: priority given to the heating circuit
  - Time: timed priority between the two circuits
  - Parallel: contemporaneous operation with priority on heating until the setpoint is reached.
- Timer programme: seasonal, holiday, groups of homogeneous zones
- Screen displays:
  - Delivery temperature
  - Return temperature
  - DHW temperature
  - Outdoor temperature
  - Flue gas temperature
  - System temperature (common delivery)
  - Fan speed
  - Ionization
  - Status
  - Error
- Control interface and motherboard with the following functions:
  - Integrated master (managing) / Slave (depending) management
  - Boiler circulator and system control by means of a signal chosen from:
    - Digital low voltage PWM (pulse width modulation) with 100-4000 Hz frequency range
    - Analogue 0-10V
    - Standard 230 VAC
  - External 0-10V analogue input for supervision through the external BMS system
  - Door with ModBus protocol for the communication with the external BMS system
  - Input for room \ door thermostat with Open Therm protocol (room probes belonging to class V, VI)

#### **SAFETY DEVICES**

All appliance functions are electronically controlled by a dual processor technology board approved for safety functions. Any malfunction results in the appliance being shut down and the automatic closure of the gas valve.

The following are installed on the water circuit:

- Safety thermostat;
- Flow sensor capable of monitoring the main circuit's flow on an ongoing basis and of stopping the appliance in the event of insufficient flow;
- Temperature sensor on delivery and return that continually measure the temperature difference between input and output fluids and enable the control to be activated;
- Minimum pressure switch calibrated at 0.7 bar.

The following are installed on the combustion circuit:

- Gas solenoid valve in class B+C, with pneumatic gas flow compensation depending on the suction line's air flow rate;
- Ionisation electrode for flame ignition and detection;
- Flue gases temperature probe. In case the maximum admissible temperature is exceeded, the module is stopped.

# RIELLO

RIELLO S.p.A. –  
37045 Legnago (VR) Italy  
tel. +39 0442 630111

[www.riello.com](http://www.riello.com)



Riello reserves the right to change the information and specifications contained in this document at any time and without notice. The contents and information contained herein are for informational purposes only and they are not intended of providing legal or professional advice. This document therefore, cannot be considered binding on third parties.



©2023 Carrier. All Rights Reserved.  
All trademarks and service marks referred herein  
are property of their respective owners.