

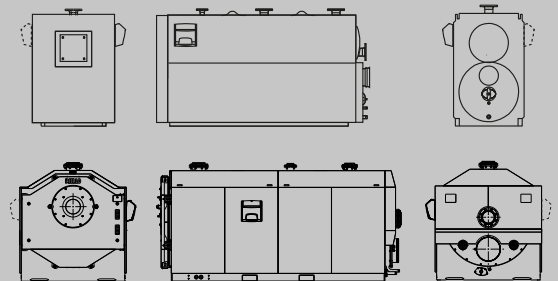

Tau N

Gas condensing steel boilers with three passes

Compliant with Directive 2009/125/EC
Condensing stainless steel boilers with three passes
with high water content that can be combined with
gas burners



CONDENSING GENERATORS

Gas condensing forced draught boilers

Tau N

PRODUCT DESCRIPTION

TAU N is a condensing boiler, with high water content for installation in a plant room; suitable for heating and domestic hot water production, in combination with a suitable heater.

Three-pass boiler, in which all parts in contact with the combustion products are in titanium stabilised stainless steel, designed on the principle of heat stratification: the combustion chamber at the top and the tube bundle at the bottom (smooth tubes with removable turbulators) allow optimising the heat exchange and energy efficiency, so as to obtain high efficiency, thanks to the condensation technique.

The generator has been designed with a structure able to contain thermal expansion; particular attention has been paid to the containment of heat losses thanks to the use of high density glass wool mats, for the thermal insulation of the boiler body, the panelling and the front door.

Some models are also available in a modular version.

The models up to 1450 kW are developed with a vertical structure with overlapping platings, to facilitate handling and make it possible to easily introduce them into the plant room.

The new 2100-2600 models are developed on a "square" structure with a single plating, to maintain the high water content and ensure maximum efficiency at the same time.

To make inspection, maintenance and cleaning of internal parts easier and reduce intervention times, the front door and the flue gas chamber closure can be opened completely.

- Low body average temperature and rapid set-up times
- Multiple system solutions thanks to the combination with the RIELLOtech control panels
- Integrated condensate drain
- Maximum operating pressure: 6 bar.

TAU 115 N ÷ TAU 800 N TECHNICAL DATA

MODELS	U.M.	TAU							
		115 N	150 N	210 N	270 N	350 N	450 N	600 N	800 N
Material		STEEL	STEEL	STEEL	STEEL	STEEL	STEEL	STEEL	STEEL
Efficiency class		> 93 + 2 log Pn	> 93 + 2 log Pn	> 93 + 2 log Pn	> 93 + 2 log Pn	> 93 + 2 log Pn	> 93 + 2 log Pn	> 93 + 2 log Pn	> 93 + 2 log Pn
Supply fuel		Natural gas/LPG - Desulphurised light oil (S < 15 ppm) - Non-desulphurised light oil only if a minimum return temperature of > 55°C is guaranteed							
Test ambient temperature	°C	20	20	20	20	20	20	20	20
Max. power	kW	115,0	150,0	210,0	270,0	350,0	450,0	600,0	800,0
Min. power (max) (*)	kW	80,0	111,0	151,0	211,0	271,0	351,0	451,0	601,0
Min. power (burner minimum)	kW	Check with burner							
Max. nominal power 80-60°C	kW	112,4	146,6	205,2	264,3	343,7	441,9	589,2	785,6
Min. nominal power 80-60°C (max.) (*)	kW	78,4	108,2	147,5	207,2	266,4	345,0	443,3	590,8
Min. nominal power 80-60°C (burner minimum)	kW	Check with burner							
Max. nominal power 50-30°C	kW	122,5	159,8	223,7	287,6	372,8	479,3	639,0	852,0
Min. nominal power 50-30°C (max.) (*)	kW	85,6	118,8	161,6	225,8	290,0	374,5	482,6	643,1
Min. nominal power 50-30°C (burner minimum)	kW	Check with burner							
30% thermal output with 30°C return	kW	33,7	44,0	61,6	79,3	103,1	132,6	176,8	235,7
Efficiency at max. power 80-60°C	%	97,7	97,7	97,7	97,9	98,2	98,2	98,2	98,2
Efficiency at min. power 80-60°C (max.) (*)	%	98,0	97,5	97,7	98,2	98,3	98,3	98,3	98,3
Efficiency at min. power 80-60°C (burner minimum) (*)	%	Check with burner							
Efficiency at max. power 50-30°C	%	106,5	106,5	106,5	106,5	106,5	106,5	106,5	106,5
Efficiency at min. power 50-30°C (max.) (*)	%	107,0	107,0	107,0	107,0	107,0	107,0	107,0	107,0
Efficiency at min. power 50-30°C (burner minimum)	%	Check with burner							
30 % working efficiency	%	108,3	108,5	109,3	109,2	108,7	108,7	108,7	108,7
Losses at chimney with burner off	%	0,1	0,1	0,1	0,1	0,1	0,1	0,1	0,1
Losses at chimney with burner on max. power	%	1,7	1,7	1,7	1,5	1,5	1,9	1,9	1,9
Losses at chimney with burner on min. power	%	1,7	2,2	2,0	1,3	0,7	1,1	1,1	1,1
Heat losses at the appliance casing with average temperature of 70°C and burner on	%	0,3	0,3	0,3	0,5	1,0	0,6	0,6	0,6
Heat losses at the appliance casing with average temperature of 70°C and burner off	%	0,1	0,1	0,1	0,1	0,1	0,2	0,2	0,2
Flue gas temperature at max P. and min P. 80-60°C	°C	75-65	75-65	75-65	75-65	75-65	75-65	75-65	75-65
Flue gas temperature at max P. and min P. 50-30°C	°C	45-40	45-40	45-40	45-40	45-40	45-40	45-40	45-40
Air excess at max. P		1,2	1,2	1,2	1,2	1,2	1,2	1,2	1,2

MODELS	U.M.	TAU							
		115 N	150 N	210 N	270 N	350 N	450 N	600 N	800 N
Air excess at min. P		1,2	1,2	1,2	1,2	1,2	1,2	1,2	1,2
Max-min flue gas mass airflow rate	kg/s	0,0522 / -	0,0735 / -	0,1029 / -	0,1320 / -	0,1720 / -	0,2210 / -	0,2940 / -	0,3632 / -
Flue gas residual head	Pa	Check with burner (~ 50 Pa Pmax - ~ 50 Pa Pmin)							
Flue gas side pressure drops	mbar	2,2	2,0	2,7	3,2	4,6	5,0	5,5	5,7
Furnace volume	dm ³	172,0	172,0	172,0	241,0	279,0	442,0	496,0	753,0
Total volume on flue gas side	dm ³	246,0	272,0	292,0	413,0	482,0	737,0	860,0	1290,0
Exchange surface	m ²	7,0	8,2	10,4	13,0	16,3	21,8	28,8	39,6
Volumetric thermal load (QMax)	kW/m ³	669,0	872,0	1121,0	1120,0	1254,0	1018,0	1210,0	1062,0
Specific thermal load	kW/m ²	16,2	18,0	19,9	20,4	20,9	20,1	20,3	18,5
NOx	mg/kWh	Check with burner							
Maximum condensation production at Pmax 50-30°C	l/h	11,0	18,4	27,4	31,9	40,9	52,2	73,8	88,0
Pressure drops on water side with ΔT 20°C	mbar	12,5	11,3	10,2	16,3	13,4	9,0	8,5	28,7
Pressure drops on water side with ΔT 10°C	mbar	50,0	43,2	36,0	54,0	46,4	33,8	30,2	128,7
Water content	l	375,0	323,0	360,0	495,0	555,0	743,0	770,0	1320,0
Maximum operating pressure	bar	6,0	6,0	6,0	6,0	6,0	6,0	6,0	6,0
Maximum allowed temperature	°C	110,0							
Maximum operating temperature	°C	95,0							
Boiler absorbed electric power at max. P	W	Check with burner							
Boiler absorbed electric power at min. P	W	Check with burner							
Pump absorbed electric power at max. P	W	---	---	---	---	---	---	---	---
Pump absorbed electric power at min. P	W	---	---	---	---	---	---	---	---
Flue gas drain diameter	mm	160	200	200	250	250	300	300	350
Empty weight	kg	479 + 60	510 + 50	530 + 50	677 + 60	753 + 70	1095 + 90	1250 + 120	1870 + 140
Category according to UNI 10642		B23 - B23P	B23 - B23P	B23 - B23P	B23 - B23P	B23 - B23P	B23 - B23P	B23 - B23P	B23 - B23P
Noise (Sound power)	dB(A)	Check with burner							

ERP TAU 115 N ÷ TAU 800 N TECHNICAL DATA

MODELS	U.M.		TAU							
			115 N	150 N	210 N	270 N	350 N	450 N	600 N	800 N
Room heating seasonal energy efficiency class			---	---	---	---	---	---	---	---
Water heating energy efficiency class			---	---	---	---	---	---	---	---
Nominal power	nominalP	kW	112	147	205	264	344	442	589	786
Room heating seasonal energy efficiency	ηs	%	92,0	92,0	93,0	93,0	93,0	---	---	---
DELIVERED THERMAL OUTPUT										
At nominal thermal output and at a high temperature capacity	P4	kW	112,4	146,6	205,2	264,3	343,7	441,9	589,2	785,6
At 30% of nominal thermal output and at low temperature capacity	P1	kW	33,7	44,0	61,6	79,3	103,1	132,6	176,8	235,7
EFFICIENCY										
At nominal thermal output and at a high temperature capacity	η4	%	88,0	88,0	88,0	88,2	88,5	88,5	88,5	88,5
At 30% of nominal thermal output and at low temperature capacity	η1	%	97,6	97,7	98,5	98,4	97,9	97,9	97,9	97,9
AUXILIARY ELECTRIC CONSUMPTION										
At full load	elmax	W	---	---	---	---	---	---	---	---
At partial load	elmin	W	---	---	---	---	---	---	---	---
In Standby mode	PSB	W	---	---	---	---	---	---	---	---
OTHER PARAMETERS										
Thermal losses in Standby mode	Pstby	W	300,0	300	420	540	700	---	---	---
Pilot flame energy consumption	Pign	W	---	---	---	---	---	---	---	---
Yearly energy consumption	QHE	GJ	---	---	---	---	---	---	---	---
Indoor sound power level	LWA	dB	---	---	---	---	---	---	---	---
Nitrogen oxide emissions	NOx	mg/kWh	Check with burner							
FOR COMBINED HEATING EQUIPMENT										
Water heating energy efficiency	ηwh	%	---	---	---	---	---	---	---	---
Power daily consumption	Qelec	kWh	---	---	---	---	---	---	---	---
Fuel daily consumption	Qfuel	kWh	---	---	---	---	---	---	---	---
Power yearly consumption	AEC	kWh	---	---	---	---	---	---	---	---
Fuel yearly consumption	AFC	GJ	---	---	---	---	---	---	---	---
Fuel yearly consumption	AFC	GJ	---	---	---	---	---	---	---	---

(*) The minimum power values indicate the minimum power setting level (power band approval); the minimum operating power depends on the burner installed. If necessary, ask for the nameplate of the boiler with the desired nominal power (as long as it is included within the approval band) when ordering.
NB: the boilers are approved for gas (Natural gas/LPG) operation but can also operate with desulphurised light oil (sulphur content < 15ppm). They may also be operated with non-desulphurised light oil, provided that a minimum return temperature of more than 55°C is guaranteed.

CONDENSING GENERATORS

Gas condensing forced draught boilers

TAU 1000 N ÷ TAU 3000 N TECHNICAL DATA

MODELS	U.M.	TAU								
		1000 N	1150 N	1250 N	1450 N	1750 N	2100 N	2600 N	3000 N	
Material		STEEL	STEEL	STEEL	STEEL	STEEL	STEEL	STEEL	STEEL	
Efficiency class		> 93 + 2 log Pn	> 93 + 2 log Pn	> 93 + 2 log Pn	> 93 + 2 log Pn	> 93 + 2 log Pn	> 93 + 2 log Pn	> 93 + 2 log Pn	> 93 + 2 log Pn	
Supply fuel		Natural gas/LPG - Desulphurised light oil (S < 15 ppm) - Non-desulphurised light oil only if a minimum return temperature of > 55°C is guaranteed								
Test ambient temperature	°C	20	20	20	20	20	20	20	20	
Max. power	Power band approval kW	1000,0	1150,0	1250,0	1450,0	1750,0	2100,0	2600,0	3000,0	
Min. power (max) (*)	kW	801,0	1001,0	1151,0	1251,0	1451,0	1751,0	2101,0	2601,0	
Min. power (burner minimum)	kW	Check with burner								
Max. nominal power 80-60°C	kW	982,0	1129,3	1227,5	1423,9	1718,5	2062,2	2553,2	2946,0	
Min. nominal power 80-60°C (max.) (*)	kW	787,4	984,3	1131,8	1229,7	1424,0	1721,2	2065,3	2556,8	
Min. nominal power 80-60°C (burner minimum)	kW	Check with burner								
Max. nominal power 50-30°C	kW	1065,0	1224,8	1331,3	1544,3	1863,8	2236,5	2769,0	3195,0	
Min. nominal power 50-30°C (max.) (*)	kW	857,1	1071,1	1231,6	1338,6	1552,6	2258,7	2796,5	2783,1	
Min. nominal power 50-30°C (burner minimum)	kW	Check with burner								
30% thermal output with 30°C return	kW	294,6	338,8	368,3	427,2	570,7	684,8	847,9	978,3	
Efficiency at max. power 80-60°C	%	98,2	98,2	98,2	98,2	98,2	98,2	98,2	98,2	
Efficiency at min. power 80-60°C (max.) (*)	%	98,3	98,3	98,3	98,3	98,3	98,3	98,3	98,3	
Efficiency at min. power 80-60°C (burner minimum) (*)	%	Check with burner								
Efficiency at max. power 50-30°C	%	106,5	106,5	106,5	106,5	106,5	106,5	106,5	106,5	
Efficiency at min. power 50-30°C (max.) (*)	%	107,0	107,0	107,0	107,0	107,0	107,0	107,0	107,0	
Efficiency at min. power 50-30°C (burner minimum)	%	Check with burner								
30% working efficiency	%	108,7	108,7	108,7	108,7	108,7	108,7	108,7	108,7	
Losses at chimney with burner off	%	0,1	0,1	0,1	0,1	0,1	0,1	0,1	0,1	
Losses at chimney with burner on max. power	%	1,9	1,9	1,9	1,9	1,5	1,5	1,5	1,5	
Losses at chimney with burner on min. power	%	1,1	1,1	1,1	1,1	1,4	1,5	1,5	1,4	
Heat losses at the appliance casing with average temperature of 70°C and burner on	%	0,6	0,6	0,6	0,6	0,3	0,3	0,3	0,3	
Heat losses at the appliance casing with average temperature of 70°C and burner off	%	0,2	0,2	0,2	0,2	0,2	0,2	0,2	0,2	
Flue gas temperature at max P. and min P. 80-60°C	°C	75-65	75-65	75-65	75-65	75-65	75-65	75-65	75-65	
Flue gas temperature at max P. and min P. 50-30°C	°C	45-40	45-40	45-40	45-40	45-40	45-40	45-40	45-40	
Air excess at max. P		1,2	1,2	1,2	1,2	1,2	1,2	1,2	1,2	
Air excess at min. P		1,2	1,2	1,2	1,2	1,2	1,2	1,2	1,2	
Max-min flue gas mass airflow rate	kg/s	0,4540 / -	0,5220 / -	0,5675 / -	0,6582 / -	0,750 / -	0,930 / -	1,140 / -	1,315 / -	
Flue gas residual head	Pa	Check with burner (~ 50 Pa Pmax - ~ 50 Pa Pmin)								
Flue gas side pressure drops	mbar	6,3	6,6	6,8	7,4	8,4	9,6	11,5	11,6	
Furnace volume	dm ³	845,0	1037,0	1037,0	1249,0	1593,0	1810,0	2270,0	2632,5	
Total volume on flue gas side	dm ³	1454,0	1763,0	1763,0	2097,0	2525,0	3040,0	3830,0	4440,0	
Exchange surface	m ²	46,5	56,2	56,2	62,3	77,7	93,2	115,7	136,0	
Volumetric thermal load (QMax)	kW/m ³	1183,0	1109,0	1205,0	1161,0	1098,6	1160,2	1145,4	1139,6	
Specific thermal load	kW/m ²	21,0	20,1	21,7	22,6	22,5	22,5	22,5	22,1	
NOx	mg/kWh	Check with burner								
Maximum condensation production at Pmax 50-30°C	l/h	111,4	124,2	132,7	159,5	173,0	203,0	256,0	301,0	
Pressure drops on water side with ΔT 20°C	mbar	30,6	26,0	28,4	36,3	16,0	31,0	21,0	20,0	
Pressure drops on water side with ΔT 10°C	mbar	121,5	94,0	100,4	150,1	40,0	78,0	56,0	75,0	
Water content	l	1395,0	1825,0	1825,0	1900,0	3060,0	3330,0	4700,0	5560,0	
Maximum operating pressure	bar	6,0	6,0	6,0	6,0	6,0	6,0	6,0	6,0	
Maximum allowed temperature	°C	110,0			100,0			90,0		
Maximum operating temperature	°C	95,0								
Boiler absorbed electric power at max. P	W	Check with burner								
Boiler absorbed electric power at min. P	W	Check with burner								
Pump absorbed electric power at max. P	W	---	---	---	---	---	---	---	---	
Pump absorbed electric power at min. P	W	---	---	---	---	---	---	---	---	
Flue gas drain diameter	mm	350	400	400	450	400	400	450	450	
Empty weight	kg	2085 + 160	2515 + 215	2515 + 215	3050 + 230	3985	4750	5820	6750	
Category according to UNI 10642		B23 - B23P	B23 - B23P	B23 - B23P	B23 - B23P	B23 - B23P	B23 - B23P	B23 - B23P	B23 - B23P	
Noise (Sound power)	dB(A)	Check with burner								

ERP TAU 1000 N ÷ TAU 3000 N TECHNICAL DATA

MODELS	U.M.	TAU								
		1000 N	1150 N	1250 N	1450 N	1750 N	2100 N	2600 N	3000 N	
Room heating seasonal energy efficiency class		---	---	---	---	---	---	---	---	
Water heating energy efficiency class		---	---	---	---	---	---	---	---	
Nominal power	nominalP	kW	982	1129	1228	1424	1719	2062	2553	2946
Room heating seasonal energy efficiency	η_s	%	---	---	---	---	---	---	---	
DELIVERED THERMAL OUTPUT										
At nominal thermal output and at a high temperature capacity	P4	kW	982,0	1129,3	1227,5	1423,9	1718,5	2062,2	2553,2	2946,0
At 30% of nominal thermal output and at low temperature capacity	P1	kW	294,6	338,8	368,3	427,2	570,7	684,8	847,9	978,3
EFFICIENCY										
At nominal thermal output and at a high temperature capacity	η_4	%	88,5	88,5	88,5	88,5	88,5	88,5	88,5	88,5
At 30% of nominal thermal output and at low temperature capacity	η_1	%	97,9	97,9	97,9	97,9	97,9	97,9	97,9	97,9
AUXILIARY ELECTRIC CONSUMPTION										
At full load	elmax	W	---	---	---	---	---	---	---	---
At partial load	elmin	W	---	---	---	---	---	---	---	---
In Standby mode	PSB	W	---	---	---	---	---	---	---	---
OTHER PARAMETERS										
Thermal losses in Standby mode	Pstby	W	---	---	---	---	4460	5250	5720	6140
Pilot flame energy consumption	Pign	W	---	---	---	---	---	---	---	---
Yearly energy consumption	QHE	GJ	---	---	---	---	---	---	---	---
Indoor sound power level	LWA	dB	---	---	---	---	---	---	---	---
Nitrogen oxide emissions	NOx	mg/kWh	CHECK WITH BURNER							
FOR COMBINED HEATING EQUIPMENT										
Water heating energy efficiency	η_{wh}	%	---	---	---	---	---	---	---	---
Power daily consumption	Qelec	kWh	---	---	---	---	---	---	---	---
Fuel daily consumption	Qfuel	kWh	---	---	---	---	---	---	---	---
Power yearly consumption	AEC	kWh	---	---	---	---	---	---	---	---
Fuel yearly consumption	AFC	GJ	---	---	---	---	---	---	---	---
Fuel yearly consumption	AFC	GJ	---	---	---	---	---	---	---	---

(*) The minimum power values indicate the minimum power setting level (power band approval); the minimum operating power depends on the burner installed. If necessary, ask for the nameplate of the boiler with the desired nominal power (as long as it is included within the approval band) when ordering.

NB: the boilers are approved for gas (NATURAL GAS/LPG) operation but can also operate with desulphurised light oil (sulphur content < 15ppm). They may also be operated with non-desulphurised light oil, provided that a minimum return temperature of more than 55°C is guaranteed.

CONDENSING GENERATORS

Gas condensing forced draught boilers

TAU 115 N ÷ TAU 1450 N OVERALL DIMENSIONS

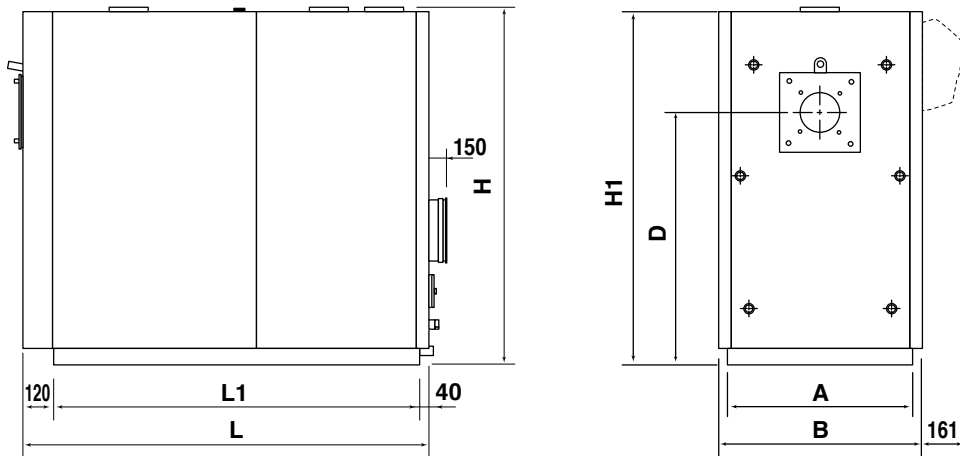

MODELS	TAU N												
	115	150	210	270	350	450	600	800	1000	1150	1250	1450	
A - Passage width	mm	690	690	690	750	750	790	790	980	980	1070	1070	1130
B - Width	mm	760	760	760	820	820	890	890	1080	1080	1170	1170	1225
L - Length	mm	1455	1455	1455	1630	1830	2035	2235	2560	2810	3010	3010	3080
L1 - Base length	mm	1295	1295	1295	1470	1670	1875	2075	2400	2650	2830	2830	2850
H - Height of hydraulic connections	mm	1315	1315	1315	1450	1450	1630	1630	1910	1910	2030	2030	2180
H1 - Boiler height	mm	1300	1300	1300	1437	1437	1615	1615	1900	1900	2015	2015	2167
D - Burner axis	mm	925	925	925	1030	1030	1235	1235	1390	1390	1495	1495	1590
Boiler weight	kg	480	510	530	677	753	1095	1250	1870	2085	2515	2515	3050
Panelling weight	kg	50	50	50	60	70	90	120	140	160	215	215	230

TAU 115 N ÷ TAU 1450 N STRUCTURE

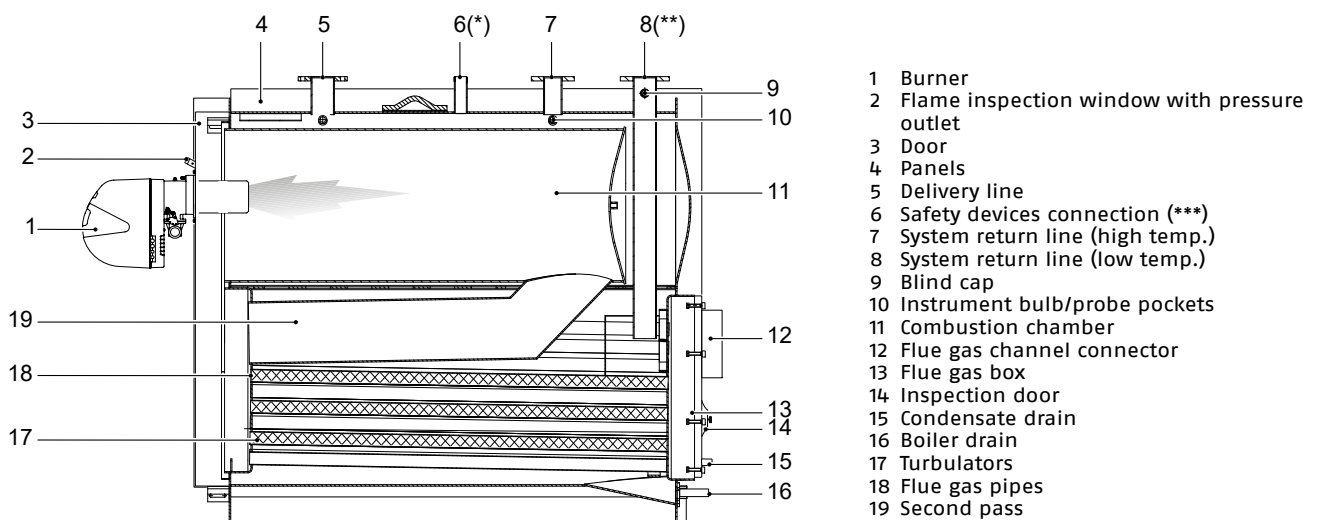

(*) from the TAU 800 N to the TAU 1450 N models the "6" safety devices connection is flanged.

(**) for TAU 1450 N models the "8" low temperature system return line is located on the back.

(**) the safety devices connection refers to regulations valid in other countries: comply with the regulations in force in the country of installation.

NOTE: In case the system uses only high temperature terminals, connect the return line of the system to the low temperature connection (8), so as to use the whole exchange surface.

TAU 1750 N ÷ TAU 3000 N OVERALL DIMENSIONS

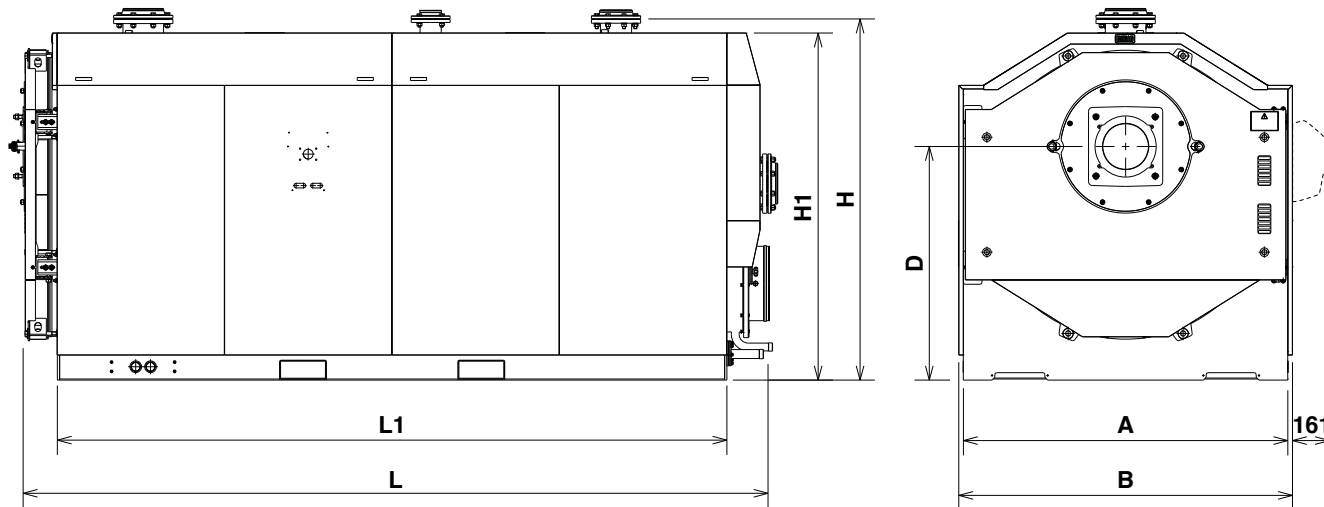

MODELS		TAU N			
		1750	2100	2600	3000
A - Passage width	mm	1750	1750	1850	1950
B - Width	mm	1800	1800	1900	2000
L - Length	mm	3620	4020	4425	4615
L1 - Base length	mm	3212	3612	4024	4206
H - Height of hydraulic connections	mm	1945	1945	2070	2170
H1 - Boiler height	mm	1870	1870	2128	2075
D - Burner axis	mm	1060	1060	1150	1210
Boiler weight	kg	3985	4750	5820	6750

TAU 1750 N ÷ TAU 3000 N STRUCTURE

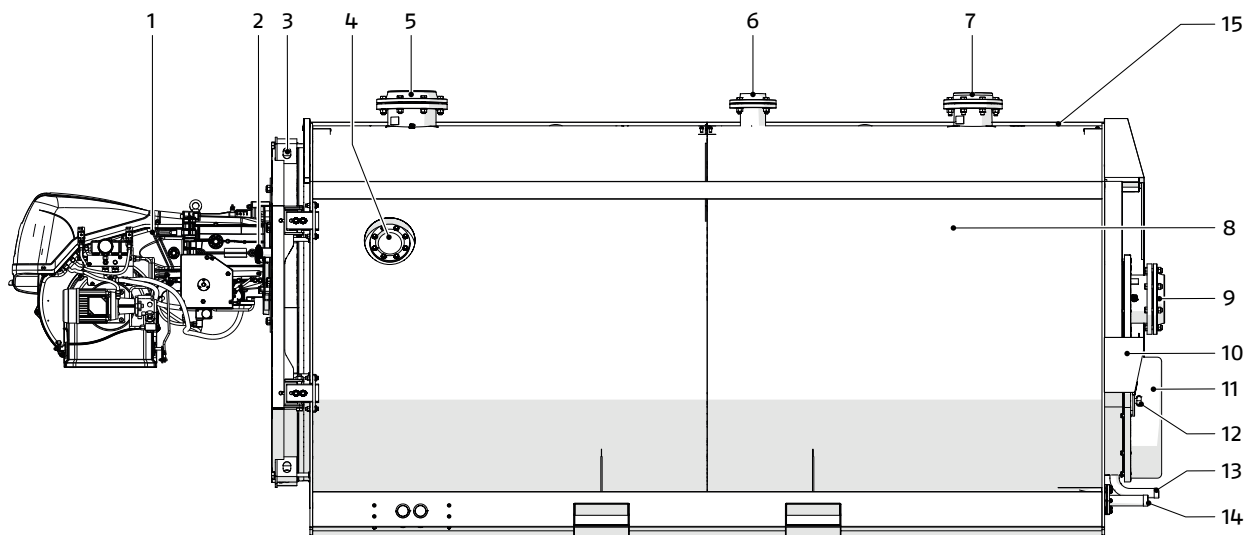

- 1 Burner
- 2 Flame inspection window with pressure outlet
- 3 Door
- 4 Internal body inspection flange
- 5 Delivery line
- 6 Safety devices connection (**)
- 7 System return line (high temp.)
- 8 Combustion chamber
- 9 System return line (low temp.)
- 10 Flue gas box
- 11 Flue gas channel connector
- 12 Inspection door
- 13 Condensate drain
- 14 Boiler drain
- 15 Support surface - maximum load 150 kg

(**) the safety devices connection refers to regulations valid in other countries: comply with the regulations in force in the country of installation.
NOTE: In case the system uses only high temperature terminals, connect the return line of the system to the low temperature connection (9), so as to use the whole exchange surface.

CONDENSING GENERATORS

Gas condensing forced draught boilers

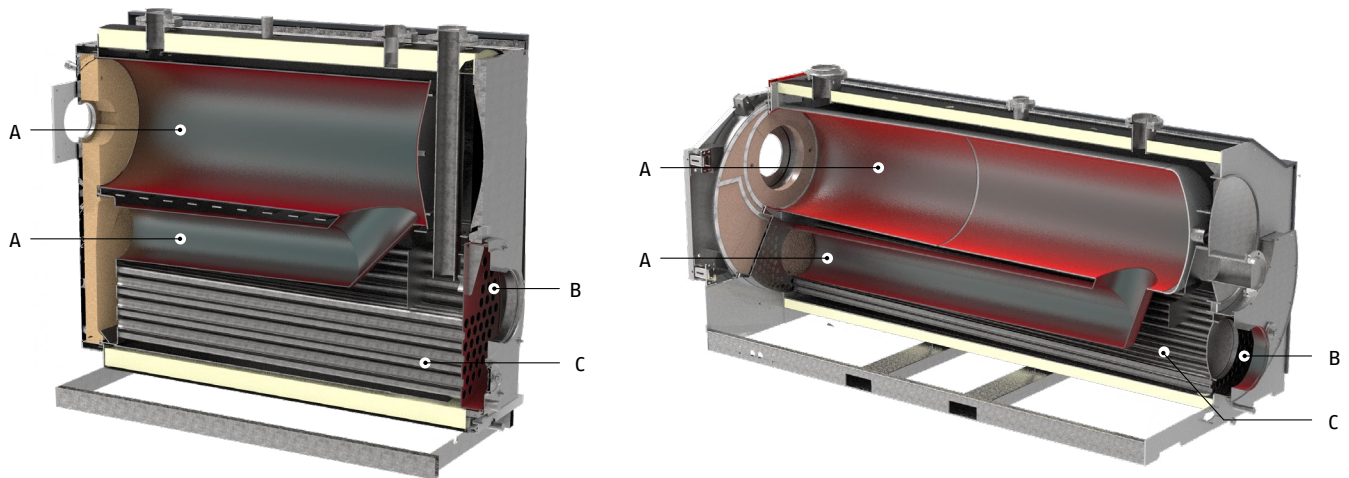

A HIGH VOLUME AND SURFACE AREA COMBUSTION CHAMBER (1ST PASS) AND FLUE GAS INVERSION PIPE (2ND PASS)

Material used AISI 321 – EN 1.4541: titanium stabilised austenitic stainless steel, an element for which it differs from AISI 304 and which gives better mechanical characteristics at high temperatures. Corrosion resistance is good in the solubilised state with respect to a wide variety of substances of interest to the chemical, textile, oil, dairy and food industries. The addition of titanium makes this steel insensitive to intergranular corrosion, and makes it suitable for use in chemical industry equipment operating at temperatures between 450° and 900°C, exhaust manifolds for endothermic engines, pressure vessels, welded structures and, precisely, boiler bodies and equipment for the petrochemical industry, expansion joints.

Dimensions: the large size of the combustion chamber (volume and exchange surface area) makes it possible to drastically reduce both the volumetric thermal load and the specific thermal load respectively and, therefore, the production of harmful emissions. The generously sized flame inversion tube reduces flue gas-side pressure drops, returning, where required, a high available head (B23P approved).

"Through flame" design: allows you not to overheat flue gas and boiler plates, preventing the formation of "Thermal NOx".

B TUBE PLATES

Material used AISI 321 – EN 1.4541: titanium stabilised austenitic stainless steel, an element for which it differs from AISI 304 and which gives better mechanical characteristics at high temperatures. Corrosion resistance is good in the solubilised state with respect to a wide variety of substances of interest to the chemical, textile, oil, dairy and food industries. The addition of titanium makes this steel insensitive to intergranular corrosion, and makes it suitable for use in chemical industry equipment operating at temperatures between 450° and 900°C, exhaust manifolds for endothermic engines, pressure vessels, welded structures and, precisely, boiler bodies and equipment for the petrochemical industry, expansion joints.

C FLUE GAS PIPES (3RD PASS)

Material used AISI 316Ti – EN 1.4571: titanium stabilised austenitic stainless steel, an element that avoids the precipitation of chromium carbides at temperatures between 450°C and 800°C and therefore ensures greater resistance to corrosion at such temperatures (in particular against pitting phenomena), typical of areas subject to welding, even in particularly reducing, highly saline environments, etc.

These characteristics make the boiler suitable for the combustion (in full condensing mode) of:

- Natural gas
- LPG
- Desulphurised light oil ($S < 15\text{ppm}$)
- In non-condensing mode (a minimum return temperature of more than 55°C must be guaranteed in order to avoid any condensation), TAU N boilers can also be operated with non-desulphurised light oil.

"Smooth tube" design: allows easy cleaning of the boiler, low pressure drops on flue gas side (high useful head – B23P) and "self-cleaning" effect.

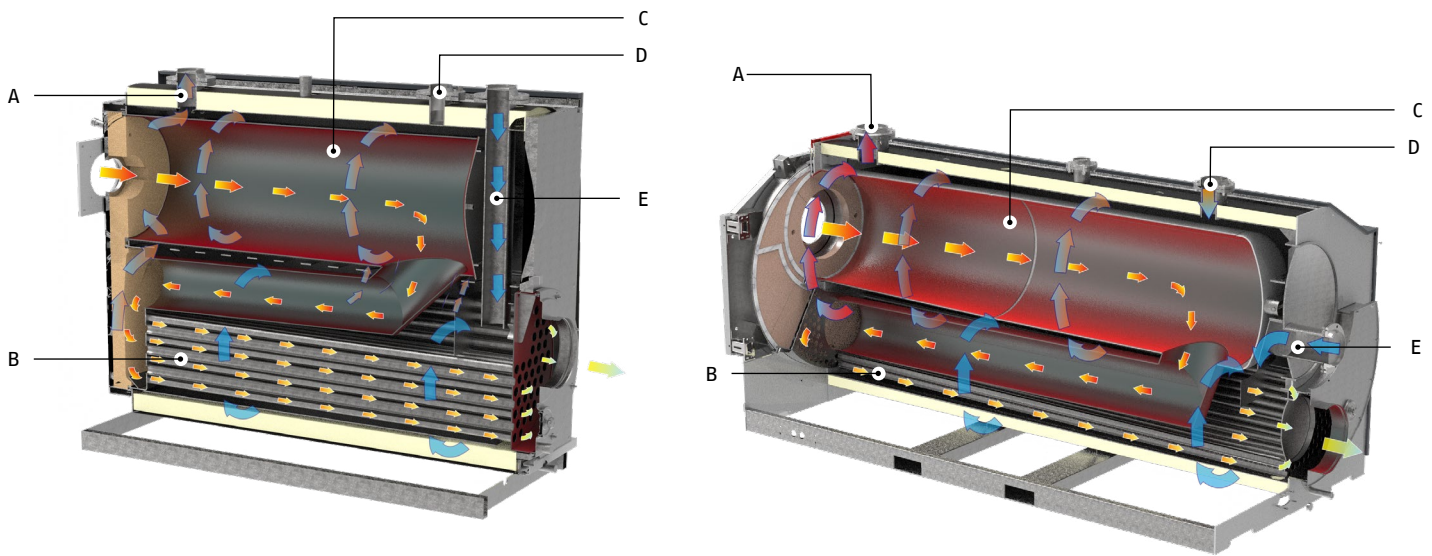

A DELIVERY LINE

B LOW TEMPERATURE AREA

Condensation area characterised by:

- High water content
- High thermal inertia
- Low temperature increases to ensure optimal condensation

C HIGH TEMPERATURE AREA:

located in the immediate vicinity of the furnace, characterised by:

- Low water content
- Low thermal inertia

D 1ST RETURN LINE:

Dedicated to high-temperature systems: the return line flows around the combustion chamber and does not affect the low temperature area dedicated to maximizing condensation

This return line is to be used only in the presence of both low and high temperature systems at the same time.

E 2ND RETURN LINE:

Dedicated to low temperature systems: the return line directly touches the end of the flue gas pipes working, therefore, on the whole available exchange surface. This return line is also used with high temperature systems when there is no area working at low temperature

The useful effect of the two return lines is not to de-stratify the boiler body. A lower average body temperature enhances the phenomenon of condensation and therefore increases yields (higher condensation production means higher energy recovery from flue gas and, therefore, higher seasonal efficiency).

CONDENSING GENERATORS

Gas condensing forced draught boilers

HYDRAULIC CONNECTIONS

TAU N steel boilers are designed and built to be installed on heating systems and also for the production of domestic hot water if connected to suitable systems. The characteristics of the hydraulic connections are shown in the table.

TAU 115 N ÷ TAU 1250 N OVERALL DIMENSIONS

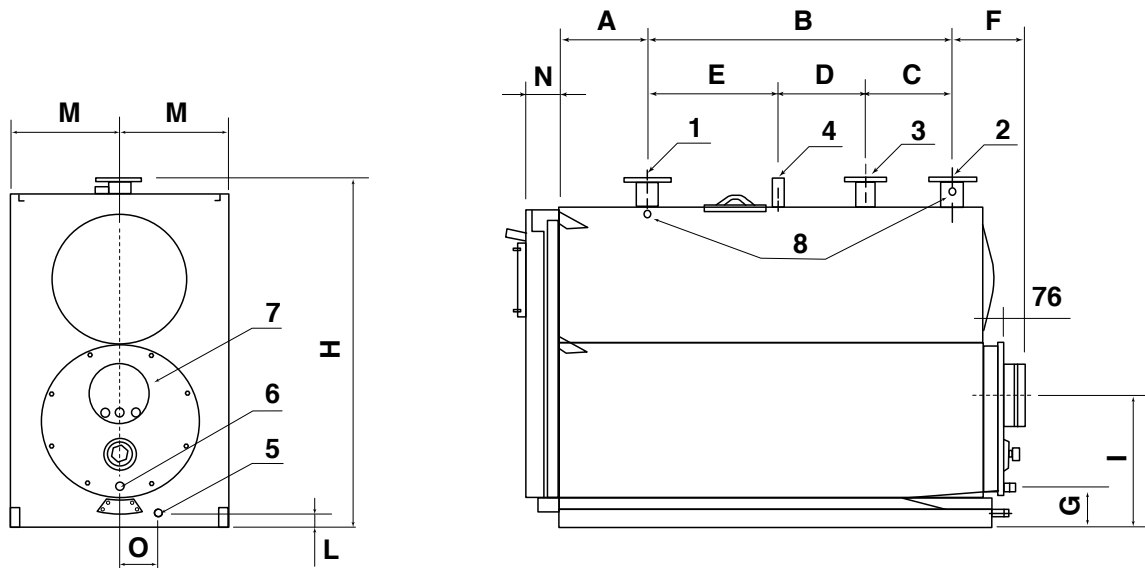

OVERALL DIMENSIONS TAU 1450 N

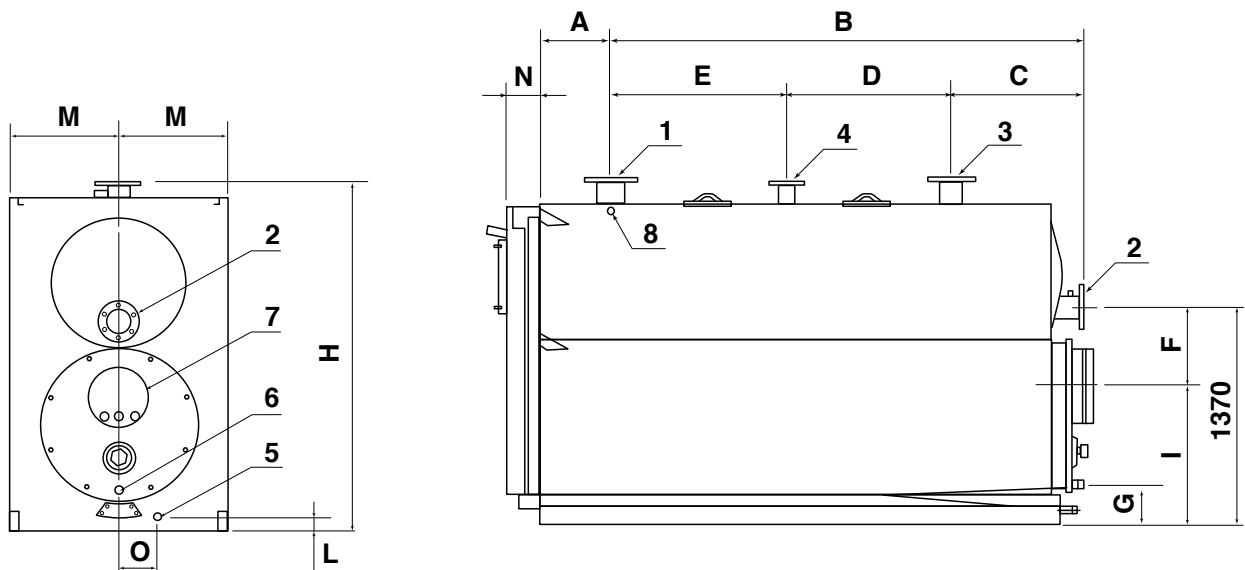

MODELS	U.M.	TAU N												
		115	150	210	270	350	450	600	800	1000	1150	1250	1450	
1 - System delivery line (*)	DN	65	65	65	65	80	100	100	125	125	150	150	150	
2 - 1st Return line (Low Temperature) (*)	DN	65	65	65	65	80	100	100	125	125	150	150	150	
3 - 2nd Return line (High Temperature) (*)	DN	50	50	50	50	65	80	80	80	80	100	100	100	
4 - Safety Devices Connection	Ø"- DN	1" 1/4	1" 1/4	1" 1/4	1" 1/4	1" 1/4	1" 1/2	1" 1/2	80	80	80	80	80	
5 - Boiler drain connection	Ø"	1"	1"	1"	1"	1"	1"	1"	1" 1/4	1" 1/4	1" 1/4	1" 1/4	1" 1/4	
6 - Condensation Drain Connection	Ø"- DN	1"	1"	1"	1"	1"	1" 1/4	1" 1/4	1" 1/4	1" 1/4	1" 1/4	1" 1/4	1" 1/4	
7 - Chimney Flue Gas Drain Connection	Ø mm	160	200	200	250	250	300	300	350	350	400	400	450	
8 - Detection bulb/probe pocket	no. x Ø"	3 x 1/2"	3 x 1/2"	3 x 1/2"	3 x 1/2"	3 x 1/2"	3 x 1/2"	3 x 1/2"	3 x 1/2"	3 x 1/2"	3 x 1/2"	3 x 1/2"	3 x 1/2"	
A - Head/ Delivery line Distance	mm	300	300	300	300	315	311	311	410	410	430	430	440	
B - 1st Delivery/return Distance	mm	885	885	885	1050	1235	1400	1600	1800	2050	2200	2200	2585	
C - 1st / 2nd Return Distance	mm	200	200	200	300	250	250	300	350	350	350	350	735	
D - Distance between 2nd Return line and connections of Safety devices	mm	285	285	285	300	450	600	700	750	850	850	850	850	
E - Distance between Delivery line and connections of Safety devices	mm	400	400	400	450	535	550	600	700	855	1000	1000	1000	
F - 1st Return line / Flue Gas Drain Distance	mm	200	200	200	225	225	270	270	325	325	345	345	560	
G - Condensation Drain Height	mm	152	152	156	156	156	215	213	195	195	213	213	235	
H - Height of Boiler Connections	mm	1340	1340	1340	1450	1450	1630	1630	1910	1910	2030	2030	2180	
I - Flue Gas Drain Height	mm	505	505	505	535	535	635	635	680	680	720	720	805	
L - Boiler Drain Height	mm	60	60	60	60	60	82	82	86	86	90	90	85	
M - Boiler Axis	mm	345	345	345	375	375	395	395	490	490	535	535	565	
N - Head/ Door Distance	mm	110	110	110	120	120	125	125	125	125	140	140	150	
O - Distance from Boiler Drain Axis	mm	132	132	132	137	137	125	125	175	175	180	180	180	

(*) All flanged connections are PN6 according to UNI EN 1092-1.

NOTE: In case the system uses only high temperature terminals, connect the return line of the system to the low temperature connection (2), so as to use the whole exchange surface.

CONDENSING GENERATORS

Gas condensing forced draught boilers

TAU 1750 N ÷ TAU 3000 N OVERALL DIMENSIONS

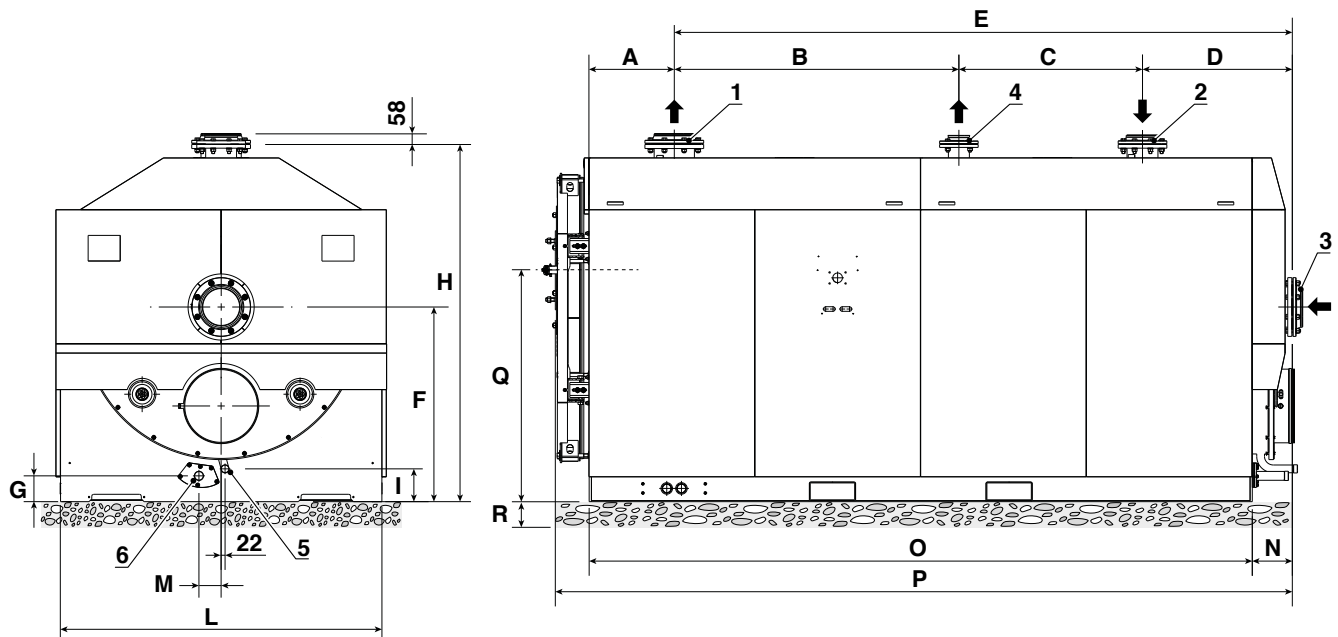

MODELS	U.M.	TAU N			
		1750	2100	2600	3000
1 - System delivery line (*)	DN	DN150 PN6	DN200 PN6	DN200 PN6	DN200 PN6
2 - 2nd Return line (High Temperature) (*)	DN	DN100 PN6	DN150 PN6	DN150 PN6	DN150 PN6
3 - 1st Return line (Low Temperature) (*)	DN	DN150 PN6	DN200 PN6	DN200 PN6	DN200 PN6
4 - Safety valve connection	DN	DN80 PN6	DN100 PN6	DN100 PN6	DN100 PN6
5 - Condensate drain	∅	1 1/4"	1 1/4"	1 1/4"	1 1/4"
6 - Boiler drain	∅	1 1/2"	1 1/2"	1 1/2"	1 1/2"
A	mm	465	465	465	465
B	mm	1348	1550	1850	1850
C	mm	950	1000	1050	1250
D	mm	665	815	880	860
E	mm	2963	3365	3780	3960
F	mm	1060	1060	1150	1210
G	mm	140	140	114	111
H	mm	1945	1945	2070	2170
I	mm	180	180	170	163
L	mm	1750	1750	1850	1950
M	mm	120	120	115	115
N	mm	215	215	220	220
O	mm	3212	3612	4024	4206
P	mm	3620	4020	4425	4605
Q	mm	1260	1260	1350	1410
R	mm	100	100	100	100

(*) All flanged connections are PN6 according to UNI EN 1092-1.

NOTE: The vertical dimensions do not include the thickness of the base.

NOTE: In case the system uses only high temperature terminals, connect the return line of the system to the low temperature connection (3), so as to use the whole exchange surface.

HYDRAULIC CIRCUIT

RIELLO TAU 115 N ÷ TAU 270 N

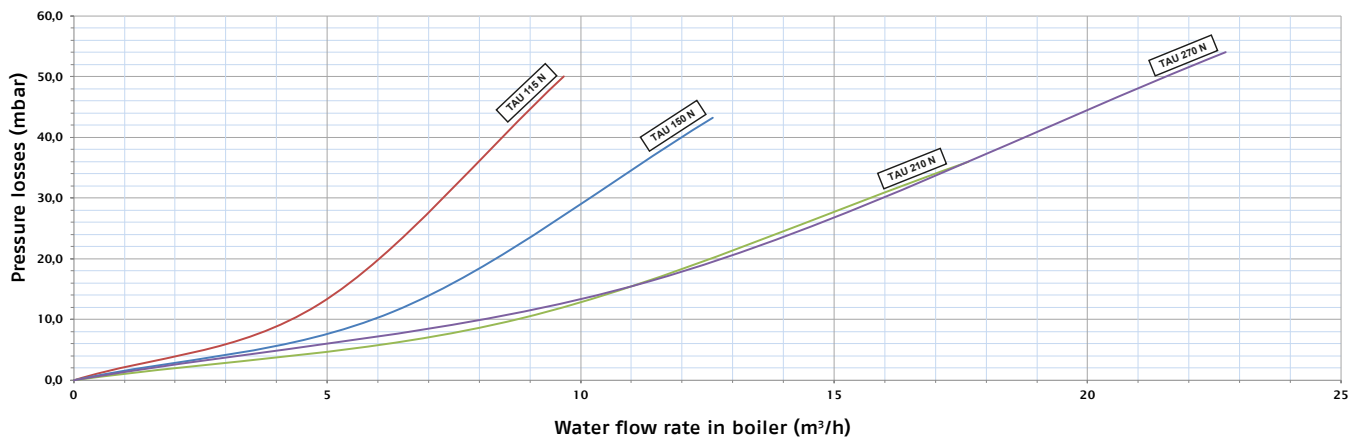

RIELLO TAU 350 N ÷ TAU 1000 N

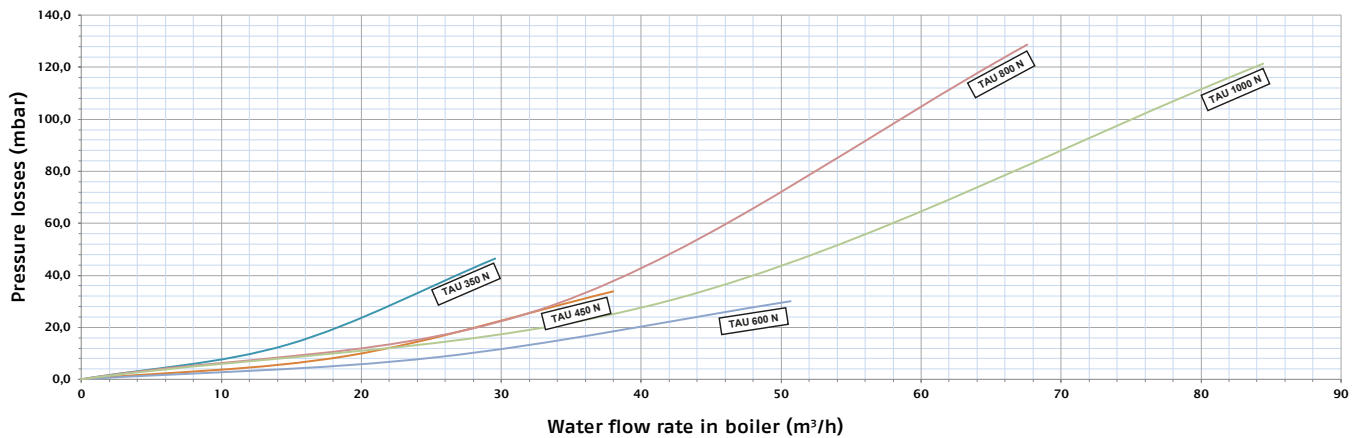

RIELLO TAU 1150 N ÷ TAU 3000 N

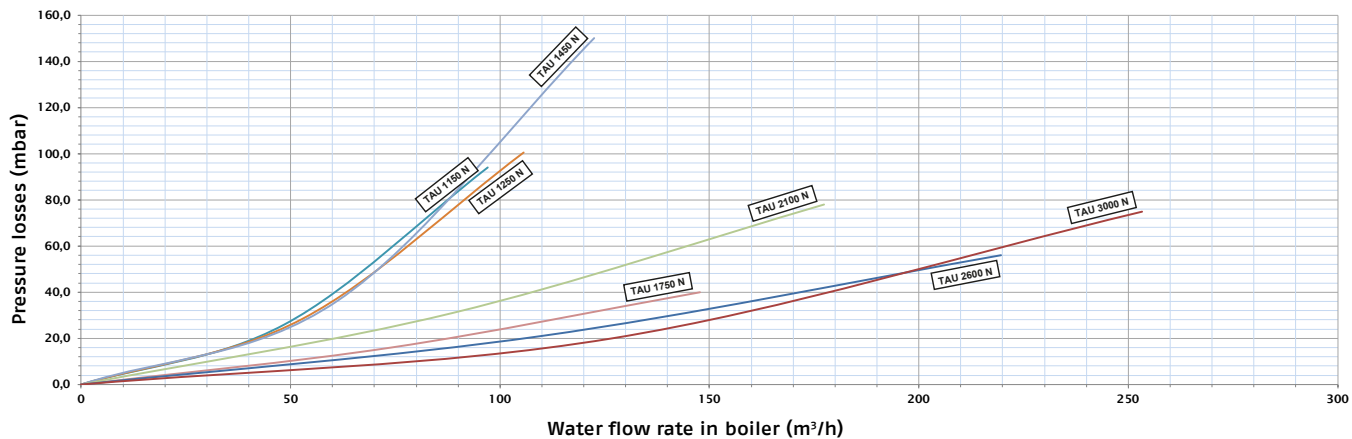

CONDENSING GENERATORS

Gas condensing forced draught boilers

WATER TREATMENT

The treatment of the system water is a NECESSARY CONDITION for the good operation and the guarantee of duration over time of the heat generator and of all the components of the system. This applies not only when working on existing systems, but also in new installations. Sludge, limestone and contaminants present in the water can lead to irreversible damage to the heat generator, even in short periods of time and regardless of the quality of the materials used.

For additional information on the type and use of additives, please contact the Technical Service Department.

COMPLY WITH THE LEGISLATIVE PROVISIONS IN FORCE IN THE COUNTRY OF INSTALLATION.

CHEMICAL-PHYSICAL CHARACTERISTICS

The chemical and physical characteristics of the water must comply with the European Standards EN 14868, EN 12953-10 and the tables below:

STEEL BOILERS			
	U/M	Initial filling water	Regular service water (*)
pH (with aluminium)		7 - 8	7 - 8,5
pH (without aluminium)		8,3 - 9,5	8,3 - 9,5
Hardness	°F	<15	<15
Electrical conductivity	µs/cm		<500
Chlorides	mg/l		<50
Oxygen (O ₂)	mg/l		<0,1
Iron (Fe)	mg/l	<0,5	<0,5 (**)
Copper (Cu)	mg/l	<0,1	<0,1 (**)
Aluminium (Al)	mg/l		<0,1 (**)
Turbidity		Clear	Clear

(*) system water values after 8 weeks of operation;

(**) higher values are due to corrosion, to be eliminated.

General note for topping up water:

- If softened water is used, it is mandatory to check again after 8 weeks after topping up that the limits for steady state water and in particular the electrical conductivity are respected;
- If purified water is used, no checks are required.

CORROSION FROM SUB-DEPOSIT

Corrosion from sub-deposit is an electrochemical phenomenon, due to the presence of sand, rust, etc. within the mass of water. These solid substances are generally deposited on the bottom of the boiler (sludge), on the tube heads and in the tube crevices. In these points micro-corrosion phenomena can occur due to the difference in electrochemical potential that is created between the material in contact with the impurities and the surrounding one.

CORROSION FROM STRAY CURRENTS

Corrosion from stray currents can occur due to different electrical potentials between the boiler water and the metal mass of the boiler or pipe. The phenomenon leaves unmistakable traces, i.e. small regular conical holes. The various metal components should therefore be grounded.

ELIMINATION OF AIR AND GASES IN HEATING SYSTEMS

The systems must always be separated if a continuous or intermittent oxygen injection occurs (e.g. underfloor heating systems without synthetic diffusion-proof plastic pipes, open-reservoir circuits, frequent top-ups).

Errors to avoid and precautions.

It is therefore important to avoid two factors that can lead to the mentioned phenomena, namely the contact between the air and the water of the system and the periodic reintegration of new water. To eliminate the contact between air and water (and avoid oxygenation of the latter), it is necessary that:

The expansion system is with closed reservoir, correctly sized and with the right pre-charge pressure (to be checked periodically);
The system is always at a pressure higher than atmospheric pressure at any point (including the suction side of the pump) and under any operating conditions (in a system, all hydraulic seals and joints are designed to withstand pressure to the outside, but not depression);

The system is not made of gas-permeable materials (e.g. plastic pipes for floor systems without an anti-oxygen barrier).

Finally, we would like to remind you that the faults suffered by the boiler, caused by encrustations and corrosion, are not covered by warranty.

HEATING SYSTEMS

Any top-up must not be carried out using an automatic loading system, but must be done manually and must be recorded in the control panel booklet. In case of several boilers, in the first period of operation they must all be operating simultaneously or with a very low rotation time in order to evenly distribute the limited initial deposit of limestone. Once the system has been completed, proceed with a washing cycle to clean the system from any processing residues. The filling water and any water for topping up the system must always be filtered (filters with synthetic or metallic mesh with a filtering capacity not lower than 50 microns) to avoid deposits that can trigger the corrosion phenomenon from sub-deposit. Before filling existing installations, the heating system must be cleaned and washed to perfection. The boiler can only be filled after washing the heating system.

NEW HEATING SYSTEMS

The first load of the system must be done slowly; once filled and deaerated, the system should not be subjected to any more reintegration. During the first start-up, the system must be brought to the maximum operating temperature to facilitate deaeration (a temperature too low prevents the gas from escaping).

REQUALIFICATION OF OLD HEATING SYSTEMS

In case the boiler is replaced, if the quality of the water complies with the requirements in the existing systems, a new filling is not recommended. If the water quality does not comply with the requirements, water reconditioning or system separation is recommended (water quality requirements must be met in the boiler circuit).

GLYCOL

The use of propylene glycol is permitted at a percentage dependent on the maximum flow temperature and design ΔT defined for the generator.

Use the diagram below to calculate the maximum percentage.

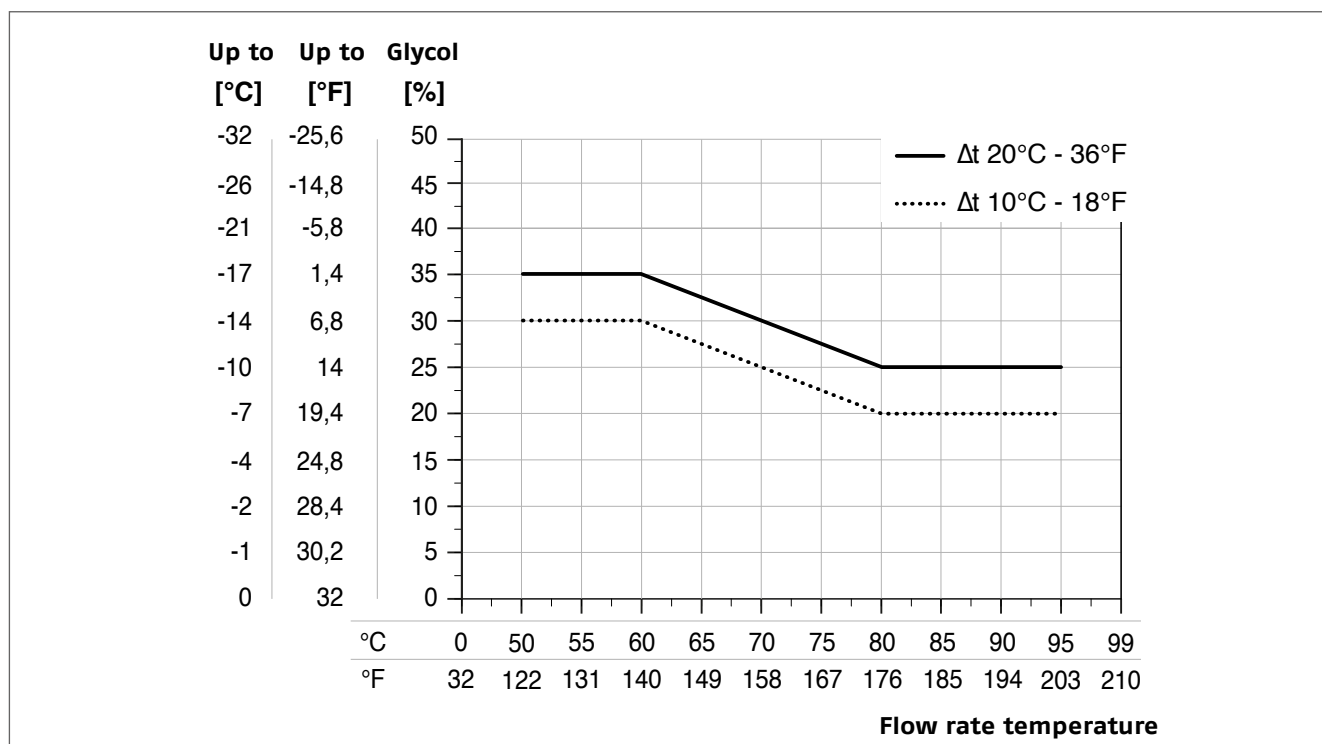

For the calculation of the freezing temperature associated with the mixture in use, refer to the technical data sheet of the product used.

IMPORTANT INFORMATION ON HEAT TRANSFER FLUIDS

Heat transfer fluids are of considerable importance for the protection of the system: heat exchange efficiency thanks to good specific heat, antifreeze properties important for the winter life of the system, anti-corrosive properties to preserve the elements of the system.

When selecting the heat transfer fluid, it is important to consider the following aspects:

- toxicity in case of losses or leakage with contamination of domestic water or water intended for human/animal contact/use
- biodegradability in case of leakage into the environment

All the heat transfer fluids proposed by Riello are non-toxic and largely biodegradable.

⚠ In order to minimize the control and maintenance or fluid change operations, a careful choice of liquid and a correct management of the heating system is essential.

CONDENSING GENERATORS

Gas condensing forced draught boilers

CONDENSATE DRAIN

TAU N condensing boilers produce a flow of condensates depending on the operating conditions. The maximum hourly condensation flow produced is indicated for every single model in the technical data table.

The condensate drain system must be sized for this value and must not show diameters smaller than that of the boiler condensate drain (7) in any point.

To prevent the combustion products from escaping into the thermal room, the siphon supplied with the boiler must be inserted in the condensation drainage path. The connecting sections between boiler and siphon and between siphon and drain into the sewage system must have an inclination of at least 3° and have a shape such as to avoid any accumulation of condensation. The siphon is equipped with a pressure outlet (G 1/8") where it is possible to connect a pipe for pressure equalization between the siphon and the flue.

⚠ Check and clean the condensate evacuation line every year.

⚠ Collecting to the sewage system must be carried out in accordance with current legislation and any local regulations.

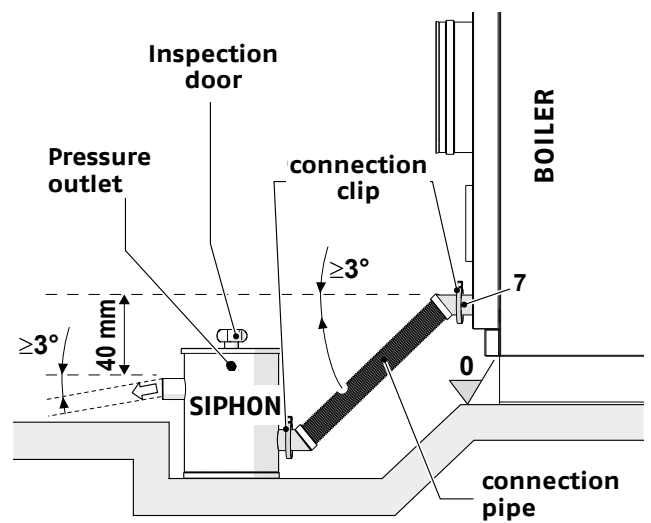
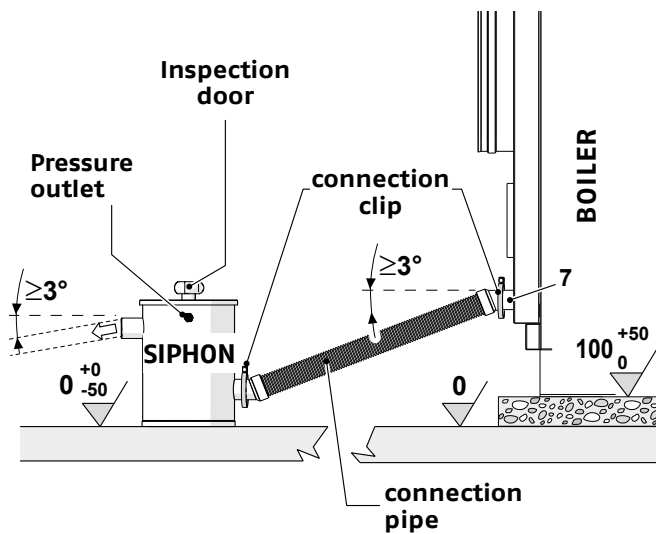

⚠ Before commissioning, fill the siphon with water up to level "L" at the upper connection.

Apply the label supplied with the siphon so that it is clearly visible and legible.

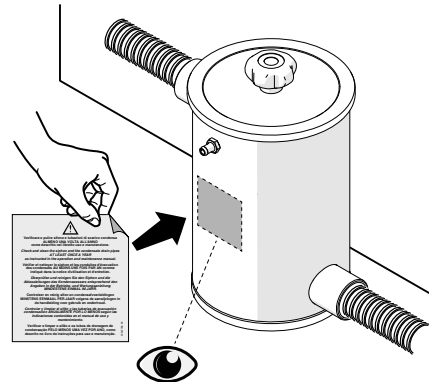
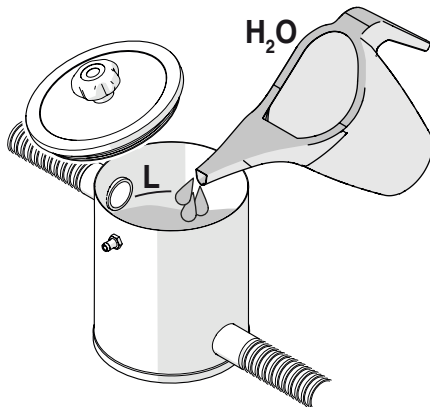

CONDENSATE NEUTRALISATION

NEUTRALISATION KIT TYPE N2-N3

The TYPE N2-N3 neutralization units have been designed for systems equipped with plant room condensate drain pocket lower than the boiler condensate drain.

These neutralisation units do not require electrical connections.

Type	UM	N2	N3
Maximum flow rate of neutralised condensate	l/h	54	180
Dimension (mm)	mm	420x300x240	640x400x240
Granulate quantity	kg	25	50
Couplings	∅	1"	1" 1/2

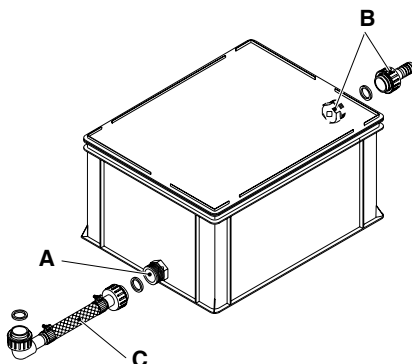

The inlet connection (A) of the neutralisation unit (lower) must be connected to the condensate drain of the boiler with the delivery hose (C) supplied with the unit. This ensures that there is no leakage of combustion products through the condensate drain pipe of the boiler.

The outlet connection (B) of the neutralisation unit (higher) must be connected to the plant room condensate drain pocket with a hose (not supplied).

- ⚠ The condensate drain pocket of the plant room must be lower than the connection (B) of the neutralisation unit.
- ⚠ The connecting pipes used must be as short and straight as possible and resistant to corrosion. The curves and the bends favour the obstruction of the pipes that prevents the correct evacuation of the condensation.

If it is necessary to neutralise the condensation produced in the chimney, it is advisable to connect the condensate drains of the boiler and the chimney with a Tee connection and then bring them to the inlet of the neutraliser.

- ⚠ Tighten the hose clamps appropriately.

CONDENSING GENERATORS

Gas condensing forced draught boilers

NEUTRALISATION UNIT TYPE HN2–HN3 (WITH PUMP)

The TYPE HN2 and HN3 neutralization units have been designed for systems equipped with plant room condensate drain pocket higher than the boiler condensate drain.

The maximum head that the pump can exceed is given by its maximum head less the resistance offered by the discharge pipe. The pump is controlled by a level electrical contact. This neutralization unit requires electrical connections, refer to the specific instructions supplied with the appliance. The protection degree of electrical connections is IP54.

	TYPE	UM	HN2	HN3
Absorbed electrical power		W	40	45
Power supply		V~Hz	230 ~ 50	230 ~ 50
Maximum flow rate of neutralised condensate		l/h	34	90
Dimensions		mm	420x300x290	640x400x320
Granulate quantity		kg	25	50
Maximum circulator head		m	6	4
Couplings		∅	1" - 5/8"	1" 1/2 - 5/8"

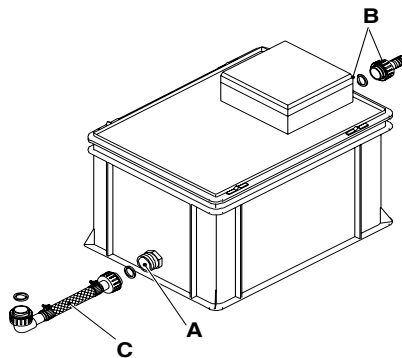

The inlet connection (A) of the neutralisation unit (lower) must be connected to the condensate drain of the boiler with the delivery hose (C) supplied with the unit. This ensures that there is no leakage of combustion products through the condensate drain pipe of the boiler.

The outlet connection (B) of the neutralisation unit (higher) must be connected to the plant room condensate drain pocket with a hose (not supplied).

⚠ The connecting pipes used must be as short and straight as possible and resistant to corrosion. The curves and the bends favour the obstruction of the pipes that prevents the correct evacuation of the condensation.

If it is necessary to neutralise the condensation produced in the chimney, it is advisable to connect the condensate drains of the boiler and the chimney with a Tee connection and then bring them to the inlet of the neutraliser.

⚠ Tighten the hose clamps appropriately.

⚠ It is also recommended to fix the pipes to the floor and protect them.

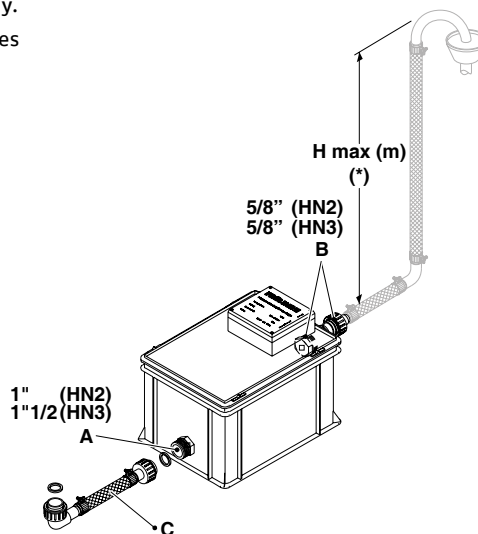

(*) The maximum head that the pump can exceed is given by its maximum head less the resistance offered by the discharge pipe.

COMBUSTION PRODUCT DRAIN

The flue gas channel and the flue connector must be made in compliance with the Standards and Regulations in force, with rigid ducts, resistant to condensate, suitable for the temperature of the combustion products, to mechanical stress and sealed. The flue must be equipped with a condensate collection and discharge module and the flue gas channel must have a slope of at least 3° towards the boiler.

DIMENSIONS (mm)	TAU N												
	115	150	210	270	350	450	600	800	1000	1150	1250	1450	
H - Height of flue gas outlet	mm	515	515	515	545	545	645	645	680	680	720	720	805
i Ø Flue gas connection diameter	mm	160	200	200	250	250	300	300	350	350	400	400	450

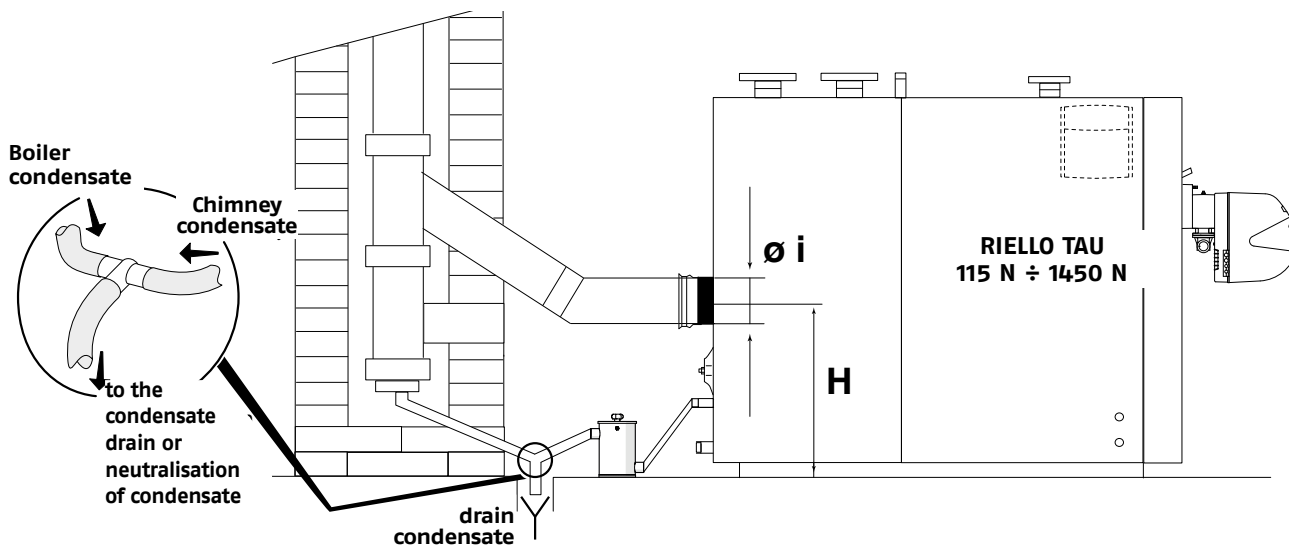

DIMENSIONS (mm)	TAU N				
	1750	2100	2600	3000	
H - Height of flue gas outlet	mm	521	521	550	600
i Ø Flue gas connection diameter	mm	400	400	450	450

⚠ The data contained in the boxes marked in grey are to be considered preliminary.

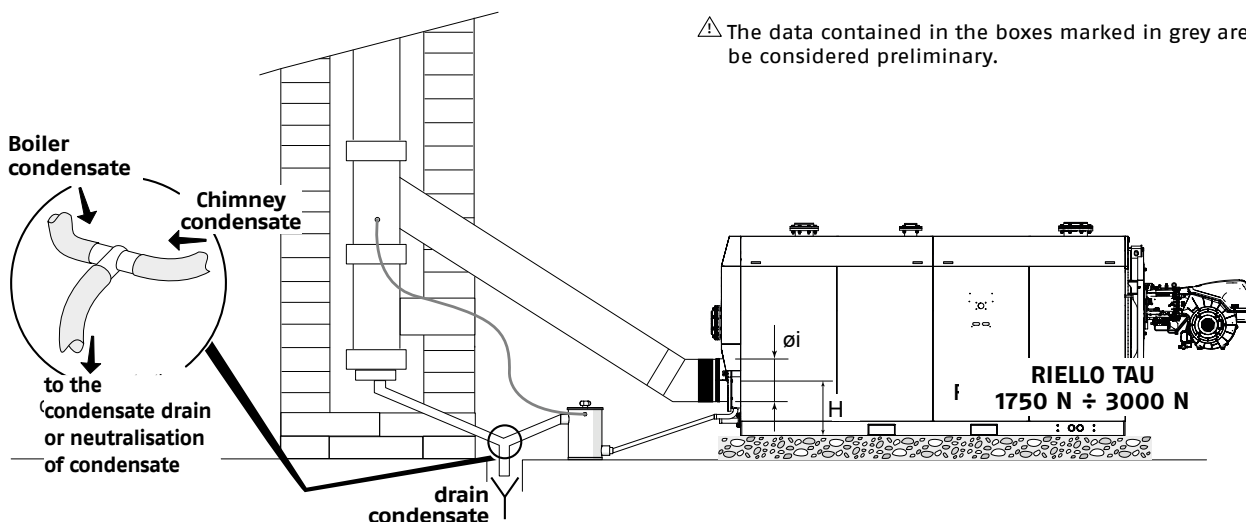

The flue must ensure the minimum depression required by the current Technical Standards, considering "zero" pressure to the connection with the flue gas channel.

Inadequate or poorly sized flues and flue gas channels can amplify the noise and negatively affect the combustion parameters.

The joint seals must be made of adequate materials (e.g. fillers, mastics, silicone preparations).

Uninsulated exhaust pipes are a source of potential danger.

When using flue gas ducts made of plastic material, it is necessary to install a safety thermostat calibrated at 90°C. The thermostat must be installed on the flue gas outlet at a distance, from the outlet of the boiler body, equal to the diameter of the flue gas outlet itself.

CONDENSING GENERATORS

Gas condensing forced draught boilers

IMPORTANT NOTES FOR BURNER ASSEMBLY

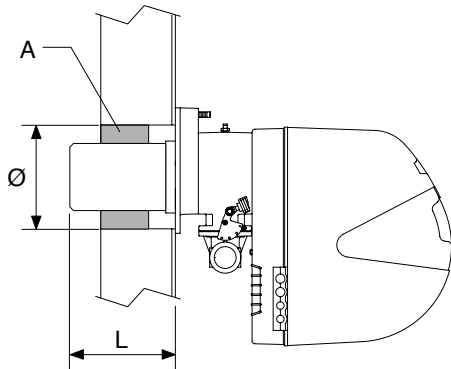

	TAU N					
	115	150	210	270	350	450
Burner head L min. (mm)	110	110	170	180	180	195
Door hole Ø (mm)	162	162	162	180	180	210

	TAU N					
	600	800	1000	1150	1250	1450
Burner head L min. (mm)	200	200	200	200	200	205
Door hole Ø (mm)	210	220	220	370	370	370

⚠ It is forbidden to use the existing burner in the case of lengths shorter than those indicated above.

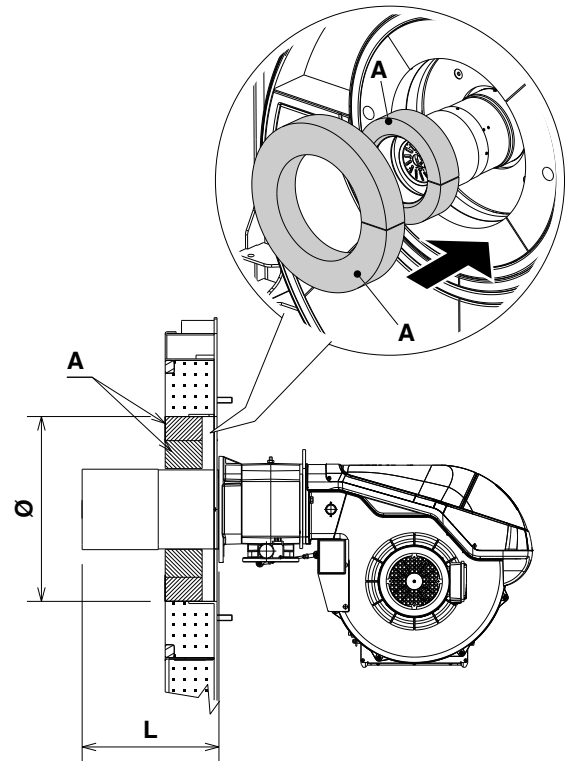

	TAU N			
	1750	2100	2600	3000
Burner head L min. (mm)	350	350	350	500
Door hole Ø (mm)	520	520	520	520

⚠ It is forbidden to use the existing burner in the case of lengths shorter than those indicated above.

COMBUSTION CHAMBER PRESSURE LOSSES

RIELLO TAU 115 N ÷ TAU 270 N

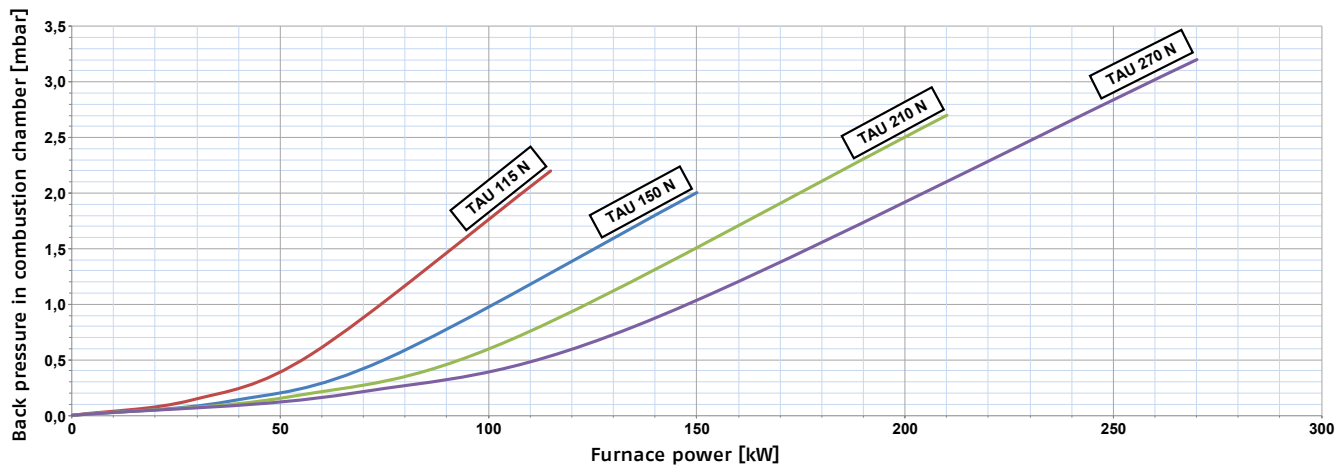

RIELLO TAU 350 N ÷ TAU 1000 N

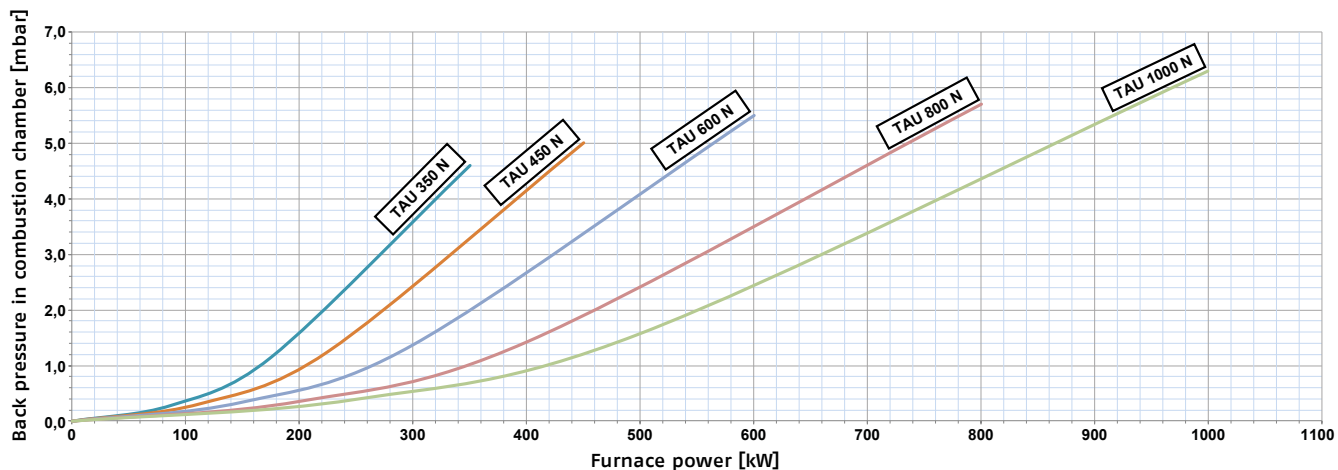

RIELLO TAU 1150 N ÷ TAU 3000 N

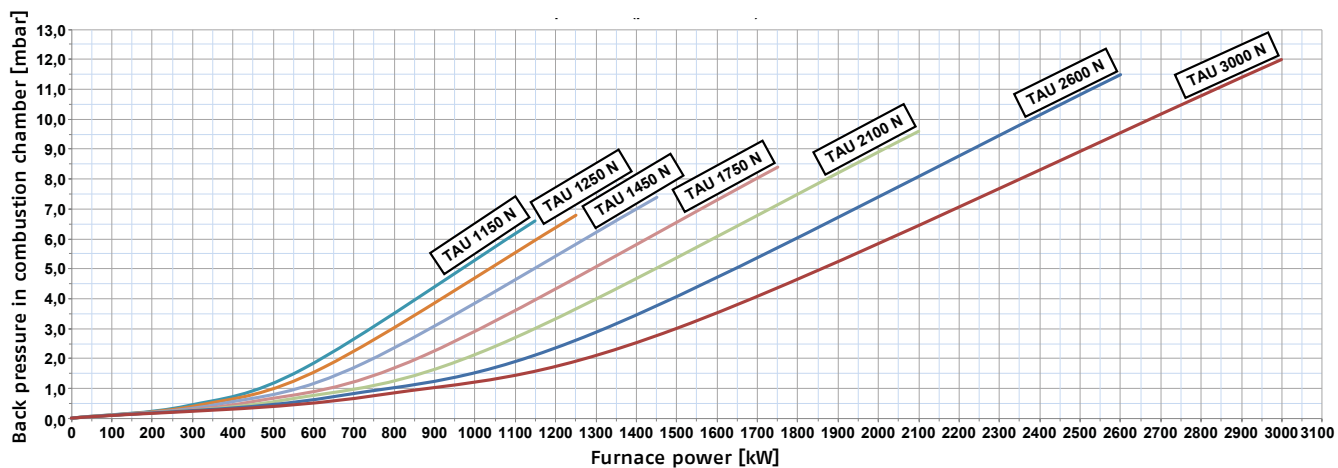

CONDENSING GENERATORS

Gas condensing forced draught boilers

FIRING RATE ACCORDING TO AIR DENSITY

The burner firing rate specified in the manual applies for an ambient temperature of 20°C and an altitude of 0 m a.s.l. (barometric pressure of approx. 1013 mbar).

The burner may have to operate at a higher altitude and/or with combustion air at a higher temperature. Both air heating and increased altitude cause air volume expansion, i.e. air density is reduced. Burner fan flow rate remains basically the same but oxygen content per cu. m of air is reduced as well as the fan thrust (head). Therefore, it is important to know whether the maximum burner output required at a certain pressure in the combustion chamber remains within the burner firing rate also under different temperature and altitude conditions. To check this, proceed as follows:

- 1 Find the correction factor F concerning air temperature and altitude for the system in Tab.F.
- 2 Divide output Q requested from the burner by F to obtain the equivalent output Qe:

$$Q_e = Q : F \text{ (kW)}$$

- 3 Within burner firing rate, mark the point identified by:

Qe = equivalent output

H1 = pressure in combustion chamber

point A that must remain within the firing rate.

- 4 Draw a vertical line from point A (Fig.3) of the graph, and calculate the maximum pressure H2 of the firing rate.
- 5 Multiply H2 by F to obtain the reduced maximum pressure H3 of the firing rate:

$$H_3 = H_2 \times F \text{ (mbar)}$$

If H3 is higher than H1, the burner can output the requested flow rate.

If H3 is lower than H1, burner output must be reduced. Output reduction is also combined with a reduction of the pressure in the combustion chamber:

Qr = reduced output

H1r = reduced pressure

$$H_{1r} = H_1 \times \left(\frac{Q_r}{Q}\right)^2$$

Example, 5% output reduction:

$$Q_r = Q \times 0.95$$

$$H_{1r} = H_1 \times (0.95)^2$$

Using the new Qr and H1r values, repeat steps 2 - 5

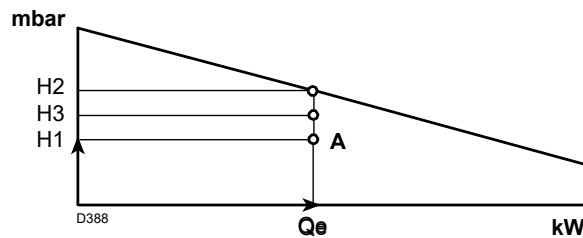

⚠ The combustion head must be adjusted according to equivalent output Qe

Fig. 3

ALTITUDE	AVERAGE BAROMETRIC PRESSURE	F								
		AIR TEMPERATURE °C								
m a.s.l.	mbar	0	5	10	15	20	25	30	40	
0	1013	1,087	1,068	1,049	1,031	1,013	0,996	0,980	0,948	
100	1000	1,073	1,054	1,035	1,017	1,000	0,983	0,967	0,936	
200	989	1,061	1,042	1,024	1,006	0,989	0,972	0,956	0,926	
300	978	1,050	1,031	1,013	0,995	0,978	0,962	0,946	0,916	
400	966	1,037	1,018	1,000	0,983	0,966	0,950	0,934	0,904	
500	955	1,025	1,007	0,989	0,972	0,955	0,939	0,923	0,894	
600	944	1,013	0,995	0,977	0,960	0,944	0,928	0,913	0,884	
700	932	1,000	0,982	0,965	0,948	0,932	0,916	0,901	0,872	
800	921	0,988	0,971	0,954	0,937	0,921	0,906	0,891	0,862	
900	910	0,977	0,959	0,942	0,926	0,910	0,895	0,880	0,852	
1000	898	0,964	0,946	0,930	0,914	0,898	0,883	0,868	0,841	
1200	878	0,942	0,925	0,909	0,893	0,878	0,863	0,849	0,822	
1400	856	0,919	0,902	0,886	0,871	0,856	0,842	0,828	0,801	
1600	836	0,897	0,881	0,866	0,851	0,836	0,822	0,808	0,783	
1800	815	0,875	0,859	0,844	0,829	0,815	0,801	0,788	0,763	
2000	794	0,852	0,837	0,822	0,808	0,794	0,781	0,768	0,743	
2400	755	0,810	0,796	0,782	0,768	0,755	0,742	0,730	0,707	
2800	714	0,766	0,753	0,739	0,726	0,714	0,702	0,690	0,668	
3200	675	0,724	0,711	0,699	0,687	0,675	0,664	0,653	0,632	
3600	635	0,682	0,669	0,657	0,646	0,635	0,624	0,614	0,594	
4000	616	0,661	0,649	0,638	0,627	0,616	0,606	0,596	0,577	

Tab. F

RECOMMENDED MATCHINGS WITH RIELLO ELECTRONIC CAM MODULATING GAS BURNERS WITH OXYGEN CONTROL

Commercial name	Min gas pressure (mbar)	Burner electronic cam with O ₂ control					Gas train					Burner accessories					Burner holder plate			Control panel						
		RS 120/E 02 BLU	RS 160/E 02 BLU	RS 200/E 02 BLU	RS 310/E 02 BLU	RS 410/E 02 BLU	MB 415/1 - RT 52	MB 420/1 - RT 52	VG D 50/1 - RT 22	VG D 65/1 - FT 122	VG D 80/1 - FT 122	VG D 100/1 - FT 122	VG D 125/1-FT122	FLANGE GAS ADAPTER DN65	FLANGE GAS ADAPTER DN80	GAS ADAPTER DN100-DN80 L=50 mm	1"1/2 - 2" ADAPTER	ADAPTER Length 400 mm DN65-DN80	ADAPTER Length 400 mm DN80-DN80	ADAPTER Length 320 mm DN125-DN80	PRESSURE SWITCH FOR GAS TRAIN	Oxygen control kit	FLANGE 350x350x12 Ø205 M12	FLANGE 400x400x15Ø230-M1	FLANGE 700x15 Ø345-n.4 M18	RIELLOTECH CLIMA COMFORT
TAU 800 N	32.0	•				•									•						•	•			•	•
	27.0	•					•														•	•			•	•
	24.0	•						•													•	•			•	•
TAU 1000 N	20.0	•						•					•								•	•			•	•
	43.0	•				•								•							•	•			•	•
	38.0	•					•								•						•	•			•	•
	31.0	•						•								•					•	•			•	•
TAU 1150 N	26.0	•						•					•								•	•			•	•
	25.0	•							•					•							•	•			•	•
	41.0	•				•									•						•	•			•	•
	38.0	•					•														•	•			•	•
TAU 1250 N	20.0	•						•					•								•	•			•	•
	19.0	•							•					•							•	•			•	•
	44.0	•				•															•	•			•	•
	28.0	•					•									•					•	•			•	•
TAU 1450 N	22.0	•						•					•								•	•			•	•
	21.0	•							•					•							•	•			•	•
	55.0	•				•															•	•			•	•
	35.0	•						•													•	•			•	•
TAU 1750 N	27.0	•						•					•								•	•			•	•
	25.0	•							•					•							•	•			•	•
	53.0	•	•					•								•					•	•			•	•
	36.0	•						•						•							•	•			•	•
TAU 2100 N	32.0	•						•					•								•	•			•	•
	29.0	•							•					•	•						•	•			•	•
	52.0				•				•												•	•			•	•
TAU 2600 N	45.0				•				•												•	•			•	•
	40.0				•					•											•	•			•	•
	58.0				•				•												•	•			•	•
TAU 3000 N	47.0				•				•												•	•			•	•
	41.0				•					•				•							•	•			•	•
	72.0				•				•												•	•			•	•
	57.0				•					•											•	•			•	•
TAU 3000 N	50.0				•					•					•						•	•			•	•
	48.0				•						•										•	•			•	•

NOTE: gas burners must be completed with gas train.

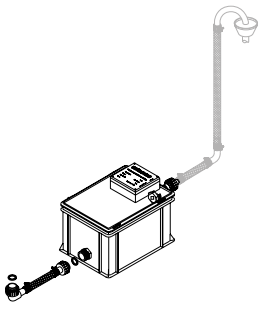
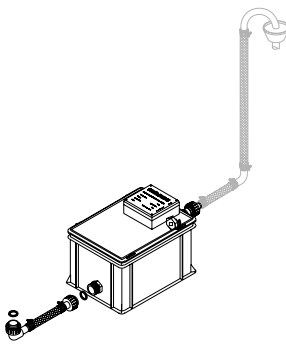
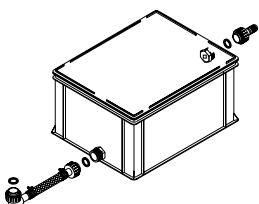
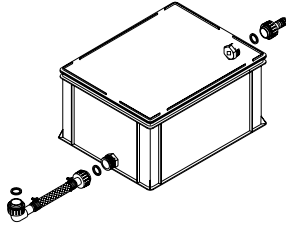
ENCLOSED DHW HEATER		TAU N																	
IMAGE	DESCRIPTION	115	150	210	270	350	450	600	800	1000	1150	1250	1450	1750	2100	2600	3000		
	<p>HN2 neutraliser kit up to 280 kW: condensate neutraliser type HN2 for gas condensing boilers up to 270 kW. The systems allows increasing pH value of the condensate from condensing boiler flue gases to values included between 6.5 and 9, so that they can be disposed of in the sewerage.</p> <p>The kits are suitable for all the installations equipped with plant room condensate drain higher than the boiler condensate drain.</p> <p>The maximum head that the pump can exceed is given by its maximum head less the resistance offered by the discharge pipe.</p> <p>The pump is controlled by a level electrical contact. The protection degree of electrical connections is IP54.</p>	●	●	●	●	○	○	○	○	○	○	○	○	○	○	○	○	○	
	<p>HN3 neutraliser kit from 280 to 750 kW: condensate neutraliser type HN3 for gas condensing boilers from 270 kW up to 750 kW. The systems allows increasing pH value of the condensate from condensing boiler flue gases to values included between 6.5 and 9, so that they can be disposed of in the sewerage.</p> <p>The kits are suitable for all the installations equipped with plant room condensate drain higher than the boiler condensate drain.</p> <p>The maximum head that the pump can exceed is given by its maximum head less the resistance offered by the discharge pipe.</p> <p>The pump is controlled by a level electrical contact. The protection degree of electrical connections is IP54.</p>					●	●	●	○	○	○	○	○	○	○	○	○	○	
	<p>N2 neutraliser kit up to 450 kW condensate neutraliser type N2 for gas condensing boilers up to 450 kW. The systems allows increasing pH value of the condensate from condensing boiler flue gases to values included between 6.5 and 9, so that they can be disposed of in the sewerage.</p> <p>The kit is designed for all those installations equipped with plant room condensate drain lower than the boiler condensate drain, therefore already inclined downwards.</p> <p>Therefore neither pump nor relevant electrical connections are required.</p>	●	●	●	●	●	●	○	○	○	○	○	○	○	○	○	○	○	○
	<p>N3 neutraliser kit from 450 to 1500 kW condensate neutraliser type N3 for gas condensing boilers from 450 kW up to 1500 kW. The systems allows increasing pH value of the condensate from condensing boiler flue gases to values included between 6.5 and 9, so that they can be disposed of in the sewerage.</p> <p>The kit is designed for all those installations equipped with plant room condensate drain lower than the boiler condensate drain, therefore already inclined downwards.</p> <p>Therefore neither pump nor relevant electrical connections are required.</p>							●	●	●	●	●	●	○	○	○	○	○	

○ = Use multiple neutralisers in parallel

CONDENSING GENERATORS

Gas condensing forced draught boilers









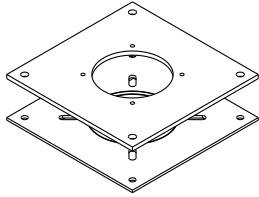

BURNER HOLDER PLATE																	
IMAGE	DESCRIPTION	TAU N															
		115	150	210	270	350	450	600	800	1000	1150	1250	1450	1750	2100	2600	3000
	<p>Burner holder plate: painted steel plate for the burner-boiler adaptation equipped with sealing gasket.</p> <p>Dimensions 350x350x12 Ø 205 M12</p>						<input type="checkbox"/>	<input type="checkbox"/>	<input type="checkbox"/>	<input type="checkbox"/>							
	<p>Burner holder plate: painted steel plate for the burner-boiler adaptation equipped with sealing gasket.</p> <p>Dimensions 400x400x15 Ø 230 M16</p>										<input type="checkbox"/>	<input type="checkbox"/>					
	<p>Burner holder plate: painted steel plate for the burner-boiler adaptation equipped with sealing gasket.</p> <p>Dimensions Ø700x15 - Ø345 - no. 4 M18</p>														<input type="checkbox"/>		
<input type="checkbox"/> = Check with the boiler/burner matching table																	
ELECTRONIC/CLIMATIC CONTROL PANELS																	
IMAGE	DESCRIPTION	TAU N															
		115	150	210	270	350	450	600	800	1000	1150	1250	1450	1750	2100	2600	3000
	<p>RIELLOtech CLIMA COMFORT (vertical): climate panel that manages single-stage, two-stage and modulating burners with climatic logic.</p> <p>The electronics can be extended to manage complex systems (even in hot/cold mode) and is fully programmable. The electrical panel is complete with plastic aesthetic cover which makes the electrical connections, tilting display panel, external temperature probe and boiler probe (submersible) safe.</p> <p>The panel is complete with INAIL approved safety thermostat which intervenes by setting the boiler in a safe stop state (burner power supply is inhibited) if the temperature exceeds the set limit (110°C).</p> <p>The panel must be installed on the casing/ side of the boiler, or on the wall (with the appropriate accessory).</p>	●	●	●	●	●	●	●	●	●	●	●	●	●	●	●	●
	<p>RIELLOtech CLIMA MIX (vertical): climatic panel (Clima Comfort accessory) that manages a direct/mixed area in hot/cold mode (it does NOT manage any burner). The electrical panel is complete with aesthetic cover in plastic material that ensures the safety of electrical connections and tilting display panel. The panel must be completed with the necessary probes (depending on the system)</p> <p>The panel must be installed on the casing/ side of the boiler, or on the wall (with the appropriate accessory).</p>	●	●	●	●	●	●	●	●	●	●	●	●	●	●	●	●
	<p>CLIMA DISPLAY: control display (plant room panel solution on DIN rail) to set Clima MIX and Clima Comfort (always for DIN rail solutions).</p>	●	●	●	●	●	●	●	●	●	●	●	●	●	●	●	●

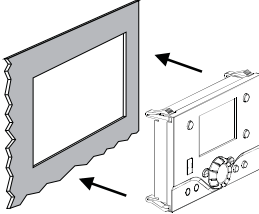
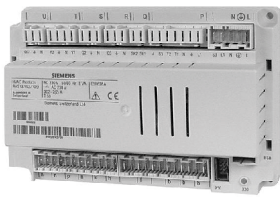
IMAGE	DESCRIPTION	TAU N															
		115	150	210	270	350	450	600	800	1000	1150	1250	1450	1750	2100	2600	3000
	<p>CLIMA COMFORT: climate panel that manages single-stage, two-stage and modulating burners with climatic logic. The electronics can be extended to manage complex systems (even in hot/cold mode) and is fully programmable.</p> <p>Plant room panel solution on DIN rail: it needs Clima Display to be programmed. The supply does NOT include probes and safety thermostat</p>	●	●	●	●	●	●	●	●	●	●	●	●	●	●	●	●
	<p>CLIMA MIX: climatic panel (Clima Comfort accessory) that manages a direct/mixed area in hot/cold mode (it does NOT manage any burner).</p> <p>Plant room panel solution on DIN rail: it needs Clima Display to be programmed. The supply does NOT include probes</p>	●	●	●	●	●	●	●	●	●	●	●	●	●	●	●	●
	<p>Programmable expansion kit (CLIMA COMFORT): programmable expansion (to be installed on DIN rail or inside the plastic cover of the RielloTech CLIMA COMFORT) which extends the system management possibilities offered by the main electronic control unit.</p> <p>In case of installation inside the plastic cover of the RielloTech CLIMA COMFORT, please note that the cover can contain at most 1 expansion</p>	●	●	●	●	●	●	●	●	●	●	●	●	●	●	●	●
	<p>Programmable expansion kit (CLIMA MIX): programmable expansion (to be installed on DIN rail or inside the plastic cover of the RielloTech CLIMA MIX) which extends the system management possibilities offered by the main electronic control unit.</p> <p>In case of installation inside the plastic cover of the RielloTech CLIMA MIX, please note that the cover can contain at most 2 expansions</p>	●	●	●	●	●	●	●	●	●	●	●	●	●	●	●	●
	<p>Relay kit for modulating burner (CLIMA COMFORT): relay kit for the management of a 3-point modulating burner</p>	●	●	●	●	●	●	●	●	●	●	●	●	●	●	●	●
	<p>Wall installation kit: allows installation on the wall of the panels for vertical installation of RielloTech CLIMA COMFORT and RielloTech CLIMA MIX equipped with plastic cover</p>	●	●	●	●	●	●	●	●	●	●	●	●	●	●	●	●

CONDENSING GENERATORS

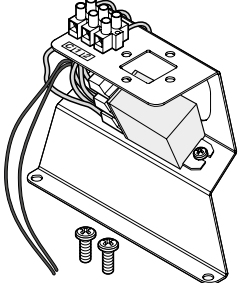
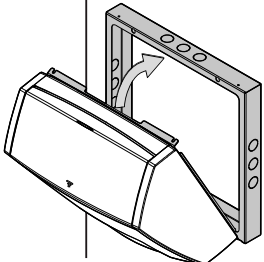
Gas condensing forced draught boilers

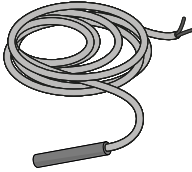
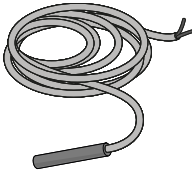
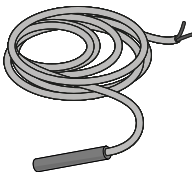
IMAGE	DESCRIPTION	TAU N															
		115	150	210	270	350	450	600	800	1000	1150	1250	1450	1750	2100	2600	3000
	<p>RC3 room control kit: control panel to be installed in the room; it can replace Clima Display</p> <p>The class V, VI or VIII ambient probe function can be activated (only when combined with a modulating burner)</p>	●	●	●	●	●	●	●	●	●	●	●	●	●	●	●	●
	<p>Ambient probe: room probe class V, VI or VIII (only if combined with a modulating burner)</p>	●	●	●	●	●	●	●	●	●	●	●	●	●	●	●	●
	<p>NTC pocket probe (10 k ohm) 5 meters: accessory probe for electronic control units</p>	●	●	●	●	●	●	●	●	●	●	●	●	●	●	●	●
	<p>NTC heater probe (10 k ohm) 5 meters: accessory probe for electronic control units</p>	●	●	●	●	●	●	●	●	●	●	●	●	●	●	●	●
	<p>NTC solar collector pocket probe (10 k ohm): accessory probe for electronic control units</p>	●	●	●	●	●	●	●	●	●	●	●	●	●	●	●	●
	<p>NTC band probe (10 k ohm): accessory probe for electronic control units</p>	●	●	●	●	●	●	●	●	●	●	●	●	●	●	●	●
	<p>NTC external probe (1 k ohm): accessory probe for electronic control units</p>	●	●	●	●	●	●	●	●	●	●	●	●	●	●	●	●

THERMOREGULATIONS – RIELLOtech

RIELLOtech is the RIELLO range of regulations created for the management of any type of system. Ideal for complex systems as well as for the management of simpler installations. The range includes:













RIELLOtech Climate Comfort: it is the climatic regulation of even complex systems in single- or multi-family installations. It manages one-stage and two-stage modulating burners (with a special kit), cascades of boilers, solar systems, and the integration of several types of heat generators. The system side manages a mixed area (expandable to 2 with a special kit), one direct and the production of domestic hot water. **RIELLOtech Clima Mix:** this is the system regulation that can manage 1 mixed area, expandable to 2 with a special kit. **RIELLOtech Prime ACS:** it is the thermostatic line able to manage one-stage and two-stage burners (using a special kit), the production of domestic hot water and a direct area. **RIELLOtech Prime:** it is the thermostatic line able to manage one-stage and two-stage burners (using a special kit) and a direct area. The RIELLOtech Clima Comfort version includes a boiler probe and an external probe. All RIELLOtech Clima regulations can be integrated via BUS. The Clima series is also available as a control panel version. IPX4D electrical protection level.



CONDENSING GENERATORS

Gas condensing forced draught boilers

INSTALLATION MODES

	BURNER	CASCADE OF BOILERS	ALTERNATE GENERATOR	SOLAR SYSTEM	DOMESTIC HOT WATER HEATER	AREA DIRECT	1ST AREA MIXED	2ND AREA MIXED
MANDATORY ACCESSORIES		Immersion probe or band probe		2 heater probes and 1 solar collector probe	Heater probe (for climate panels)		Immersion probe or band probe	Immersion probe or band probe
OPTIONAL ACCESSORIES			Immersion probe (only for biomass boiler)				Ambient probe or Remote Control RC3	Ambient probe or Remote Control RC3
RIELLOtech CLIMA COMFORT	 modulating							with kit additional dedicated mix area management
RIELLOtech CLIMA MIX								with kit additional mix area management
RIELLOtech Prime	 Two-stage with special kit							
RIELLOtech Prime ACS	 Two-stage with special kit							

THERMOREGULATIONS ERP CLASS

DESCRIPTION ACCESSORIES	PROBE EXTERNAL	BURNER	CLASS	RELAY KIT 3-POINT MODULE	ONE AMBIENT PROBE	TWO AMBIENT PROBES	THREE AMBIENT PROBES	ADDITIONAL MIX AREA MANAGEMENT + RELEVANT AMBIENT PROBE
RIELLOtech CLIMA COMFORT	Yes	Modul On/off	II III	II III	VI VII	VI VII	VIII VII	VIII VII
REMOTE CONTROL RC3			V					
AMBIENT PROBE			V					

RIELLO TAU N

DESCRIPTION FOR SPECIFICATIONS

Three-pass hot water condensing boiler, with sliding low temperature, composed of:

- Min./max. heat output (furnace) between 30–3000 kW (**power band approval**);
- Max nominal delivered output 108,2–2946,0 kW with temperature 80–60°C
- Max nominal delivered output 122,5–3195,0 kW with temperature 50–30°C
- Modulation ratio dependent on matched burner (**single-stage / two-stage / modulating / premix / with inverter fan / with O₂ probe**)
- Min./max. heat output (furnace) between 30 ÷ 3000 kW;
- Useful efficiency at Pn max. of 97,7–98,2% with temperature of 80–60°C;
- Useful efficiency at Pn max. of 106,5% with temperature of 50–30°C;
- Useful efficiency at Pn max. of 106,5–107,5% with temperature of 40–30°C;
- Useful efficiency at 30% Pn max. of 106,5–109,0%.
- Flue gas temperature between 45°C and 75°C depending on the return temperature;
- External casing composed by painted steel metal sheet panels, assembled with snap and removable couplings for total accessibility to the boiler with complete opening both of the front door and of the combustion chamber;
- Front door with ambidextrous opening without the need to remove the burner;
- Thermal insulation with a double **high density glass wool layer having a thickness of 100 mm** and protected by an aluminium sheet;
- Heat exchange surfaces in contact with the combustion products consisting of:
 - combustion chamber and inversion tube in **titanium-stabilised austenitic stainless steel AISI 321 / Euronorm 1.4541**
 - tube bundle
 These characteristics make the boiler suitable for the combustion (in full condensing mode) of:
 - **Natural gas;**
 - **LPG;**
 - **Desulphurised light oil (S < 15ppm);**
 In non-condensing mode (a minimum return temperature of more than 55°C must be guaranteed in order to avoid any condensation), TAU N boilers can also be operated with non-desulphurised light oil;
- Exchange body characterised by a large volume of water with stratification effect:
 - very low water content in the hot part, fast set-up;
 - large reserve of water in the cold part below, for maximum exploitation of the phenomenon of condensation;
- **No limit on return temperature, and no limit on water flow rate;**
- **Overheating automatically removed by the internal circulation system;**
- Actual three-pass heat exchanger to favour **low NO_x emissions and with no limit on minimum burned power;**
- Structure with a **"narrow" shape up to model 1450:** characterised by an "8" shape that divides the exchange body into two sections in order to maintain a **reduced overall dimensions of the generator and allow the passage through the door of reduced dimensions;**
- Structure with a **"square" shape up to model 3000** that maximizes the compactness of the exchanger and reduces its overall height;
- **Smooth flue gas pipes** with sub-horizontal pattern for **optimal condensate drainage**, minimization of sludge deposits, with self-cleaning effect of 1,6 mm;
- AISI 430 stainless steel turbulators to facilitate heat exchange even at very low combustion gas temperatures;
- One delivery circuit and **two system return circuits;** one for high temperature and one for low temperature with boiler water inlet at the height of the second pass;
- Connection to safety pipe;
- Probe holder pockets and regulations according to law;
- System drain;
- Condensate drain;
- Flanged sludge collection area, located in the lower part of the boiler, useful for boiler replacement in existing systems;
- **Cleaning and control of the combustion chamber and the condensation exchanger that can be carried out totally from the front;**
- Condensate collection siphon supplied;



RIELLO



RIELLO S.p.A.
37045 Legnago (VR) ITALY
tel. +39 0442 630111

www.riello.com



RIELLO reserves the right to change the information and specifications contained herein at any time and without notice. The contents and information provided herein are for informational purposes only and are not intended to provide legal or professional advice. This document, therefore, cannot be considered binding on third parties



©2025 Carrier. All Rights Reserved.
All trademarks and service marks referred
herein are property of their respective owners.