

20027281

con TUBO IN RAME Ø 18 mm
with COPPER PIPING Ø 18 mm
avec TUYAU EN CUIVRE Ø 18 mm

KIT RACCORDO COLLETTORI UNION KIT COLLECTORS KIT RACCORD POUR CAPTEURS

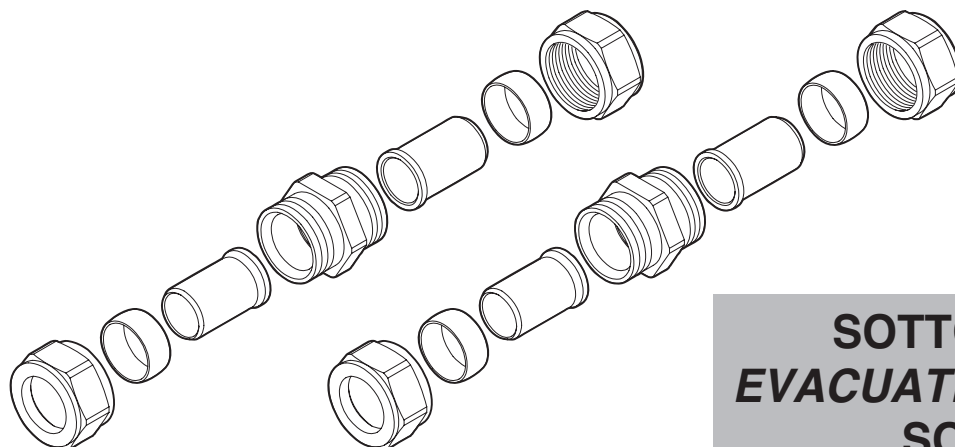

**SOTTOVUOTO
EVACUATED TUBE
SOUS VIDE**

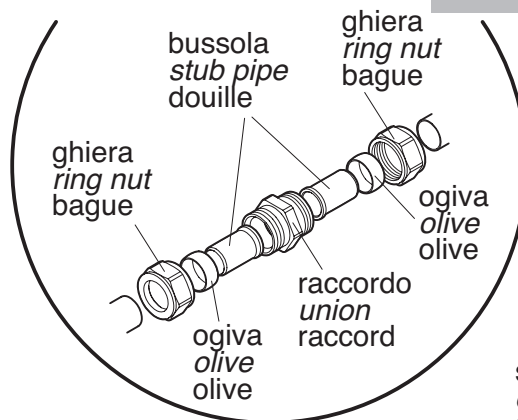

dal circuito di scambio termico
from heat exchange circuit
du circuit d'échange thermique

sondacollettore
collector temperature sensor
sonde capteur

al circuito di scambio termico
to heat exchange circuit
au circuit d'échange thermique

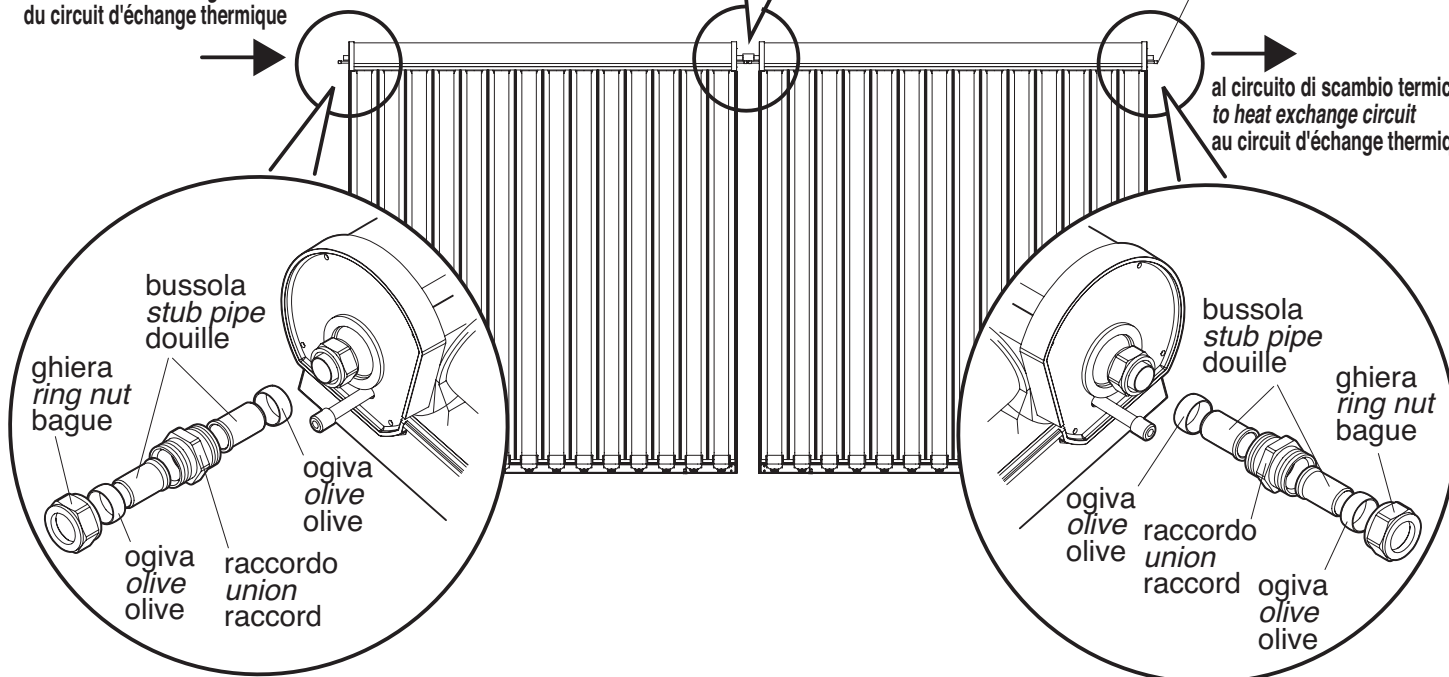

20027281

con TUBO IN RAME Ø 18 mm
with COPPER PIPING Ø 18 mm
avec TUYAU EN CUIVRE Ø 18 mm

KIT RACCORDO UNION KIT KIT RACCORD POUR

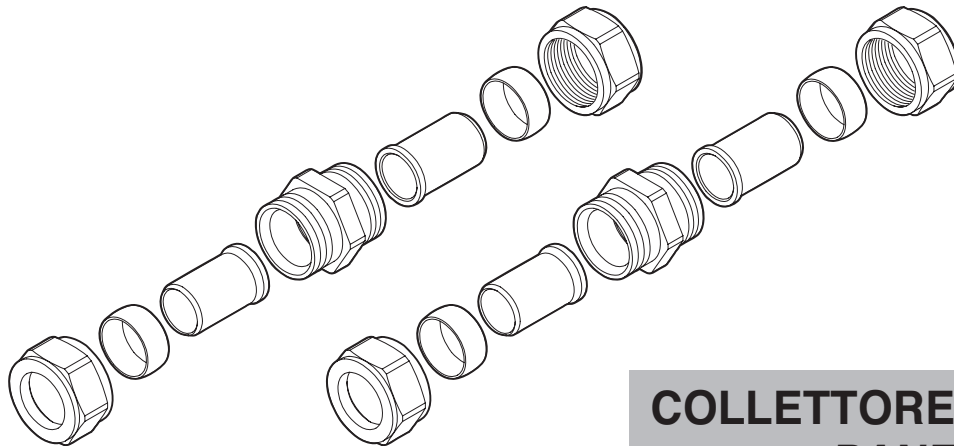

**COLLETTORE PIANO VASCA
PANEL TYPE SOLAR
COLLECTOR WITH TRAY
CAPTEUR PLAT AVEC CUVE**

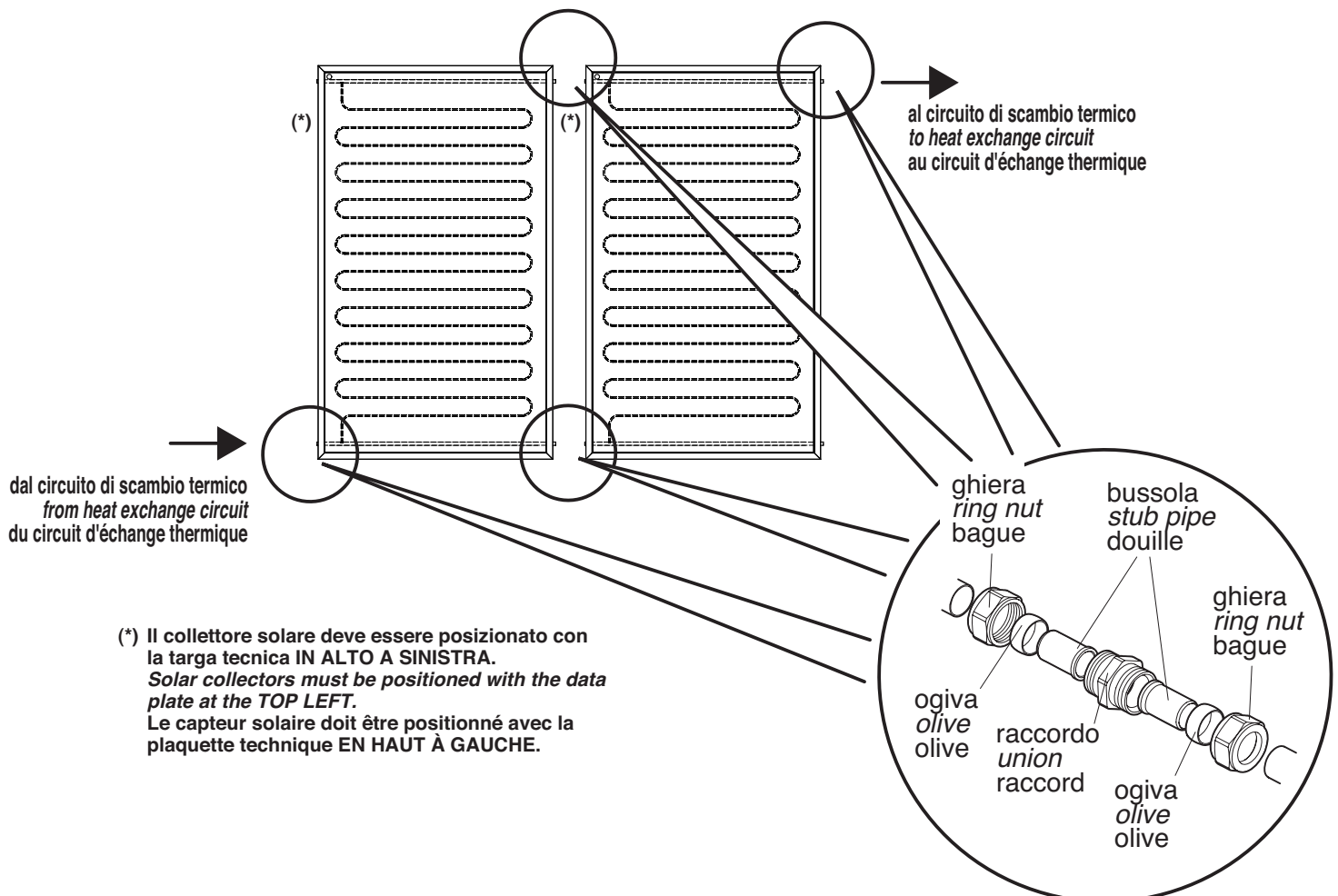

20027281

mit KUPFERROHR Ø 18 mm
met KOPEREN PIJP Ø 18 mm
con TUBO DE COBRE Ø 18 mm
com TUBO DE COBRE Ø 18 mm

ANSCHLUSSSATZ FÜR KOLLEKTOREN AANSLUITKIT VOOR COLLECTOREN KIT DE EMPALME PARA COLECTORES KIT DE LIGAÇÕES PARA COLECTORES

**VAKUUM
VACUÛM
AL VACÍO
DE VÁCUO**

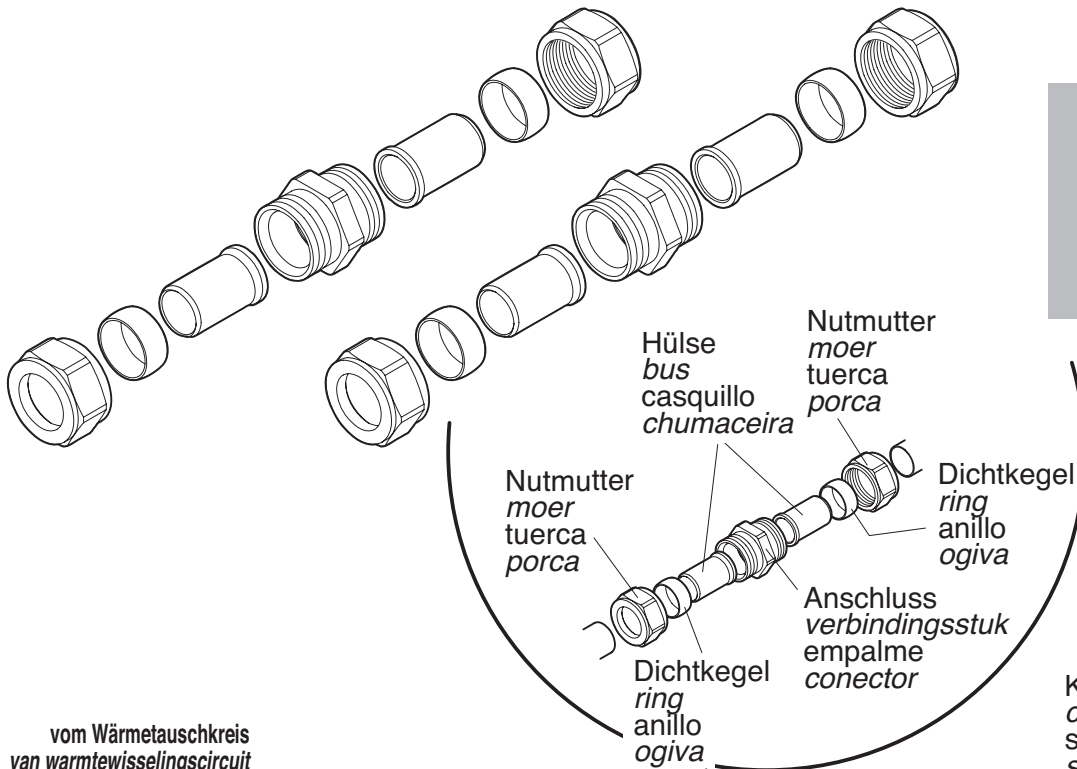

vom Wärmetauschkreis
van warmtewisselingscircuit
del circuito de intercambio térmico
do circuito de permutação de calor

Kollektorfühler
collectorsonde
sonda colector
sonda colector

zum Wärmetauschkreis
naar warmtewisselingscircuit
al circuito de intercambio térmico
para circuito de permutação de calor

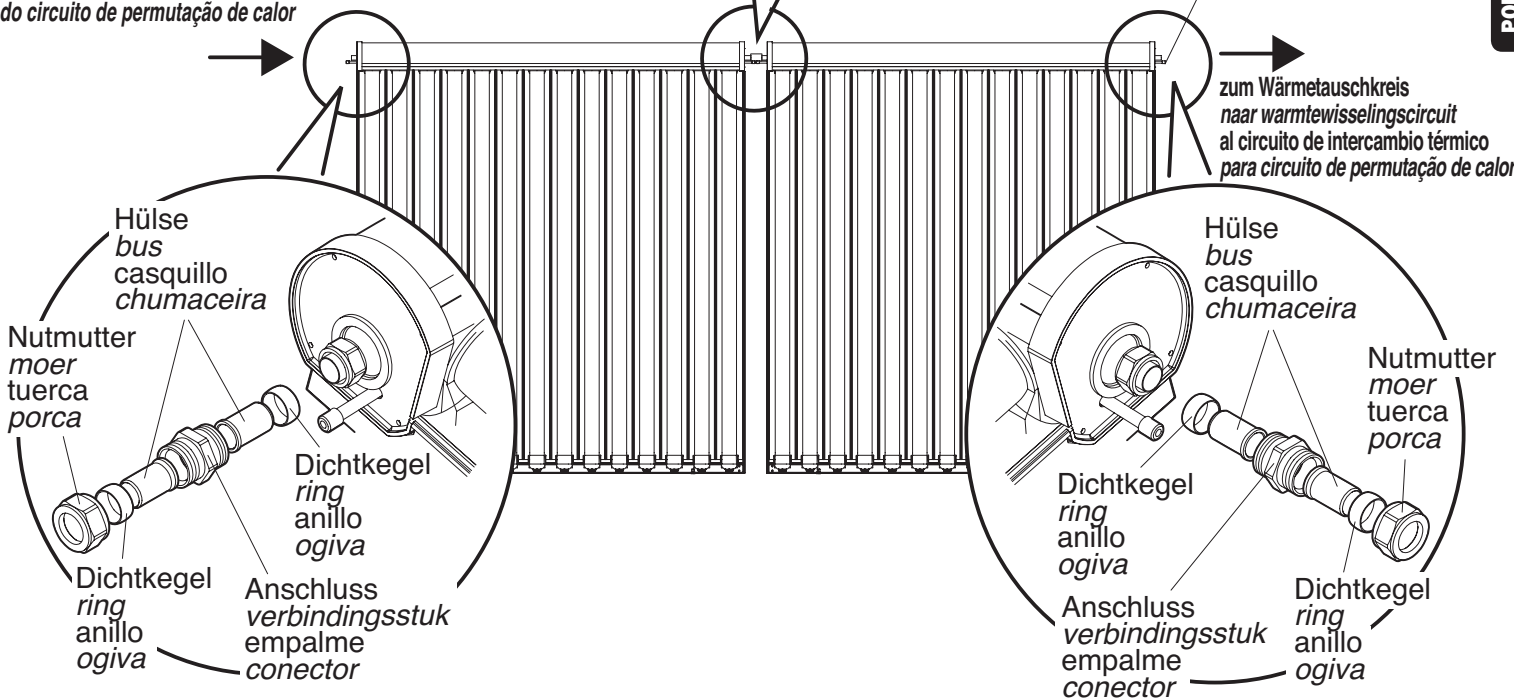

20027281

mit KUPFERROHR Ø 18 mm
met KOPEREN PIJP Ø 18 mm
con TUBO DE COBRE Ø 18 mm
com TUBO DE COBRE Ø 18 mm

ANSCHLUSSSATZ FÜR AANSLUITKIT VOOR KIT DE EMPALME PARA KIT DE LIGAÇÕES PARA

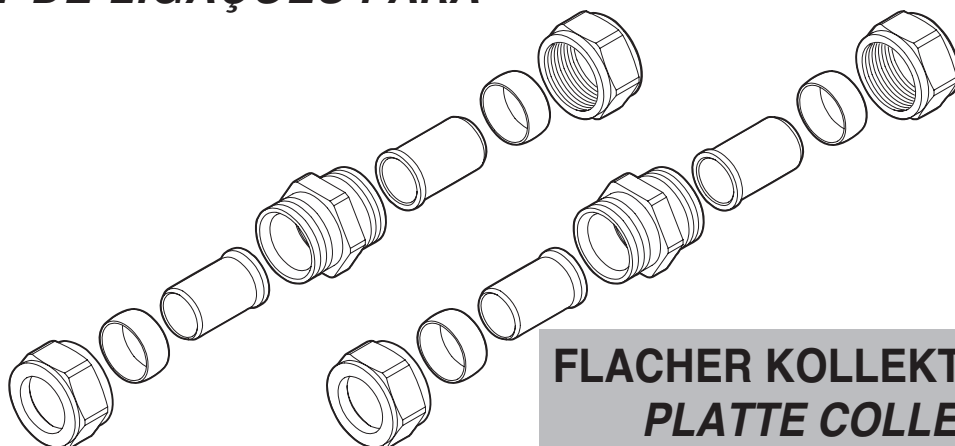

**FLACHER KOLLEKTOR MIT WANNE
PLATTE COLLECTOR MET BAK
COLECTOR PLANO CON DEPÓSITO
COLETOR PLANO COM DEPÓSITO**

PORTUGUÊS ESPAÑOL NEDERLANDS DEUTSCH

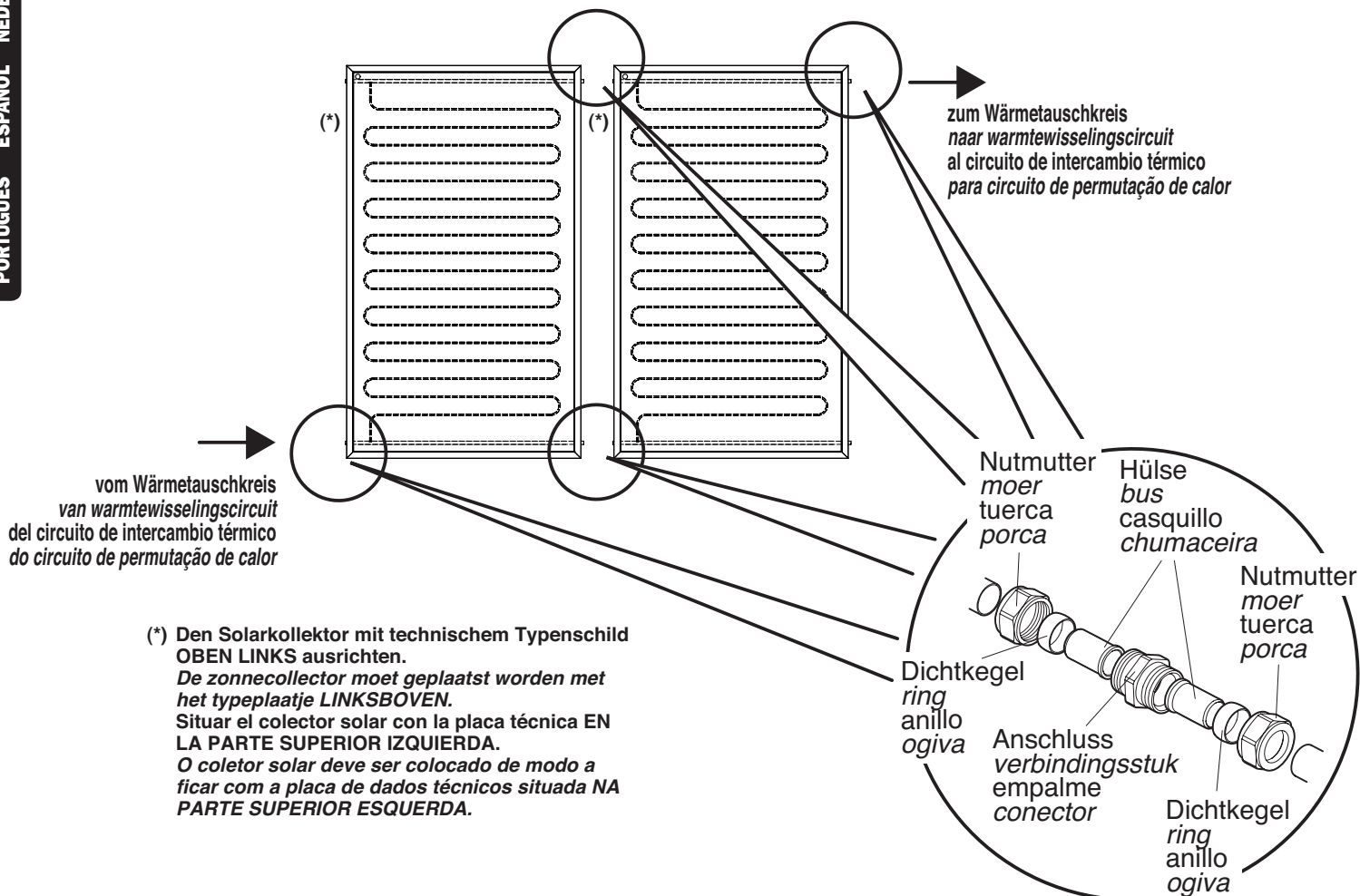

20027281 sa BAKARNOM CEVI Ø 18 mm
z BAKRENO CEVJO Ø 18 mm

**OPREMA ZA PRIKLJUČAK KOLEKTORA
KOMPLET PRIKLJUČKOV ZA KOLEKTORJE**

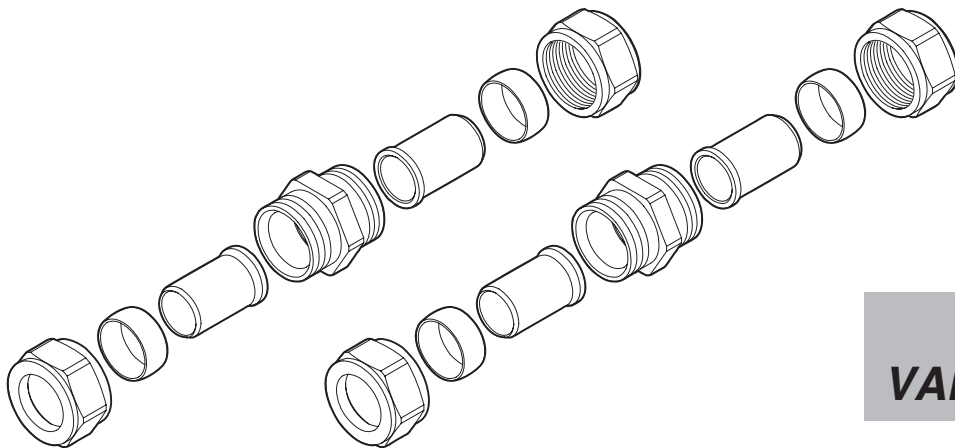

**VAKUUM
VAKUUMSKI**

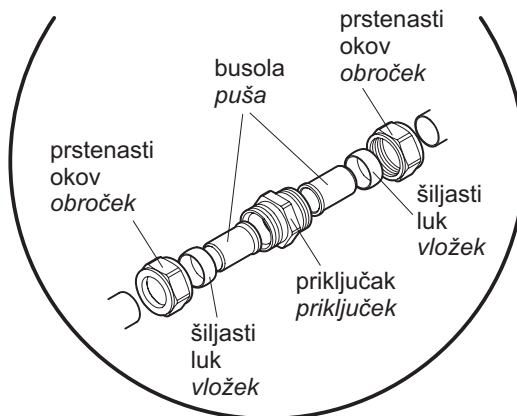

sa strujnog kola termičke razmene
iz sistema za toplotno izmenjavo

sonda kolektorja
tipalo kolektorja

na strujno kolo termičke razmene
v sistem za toplotno izmenjavo

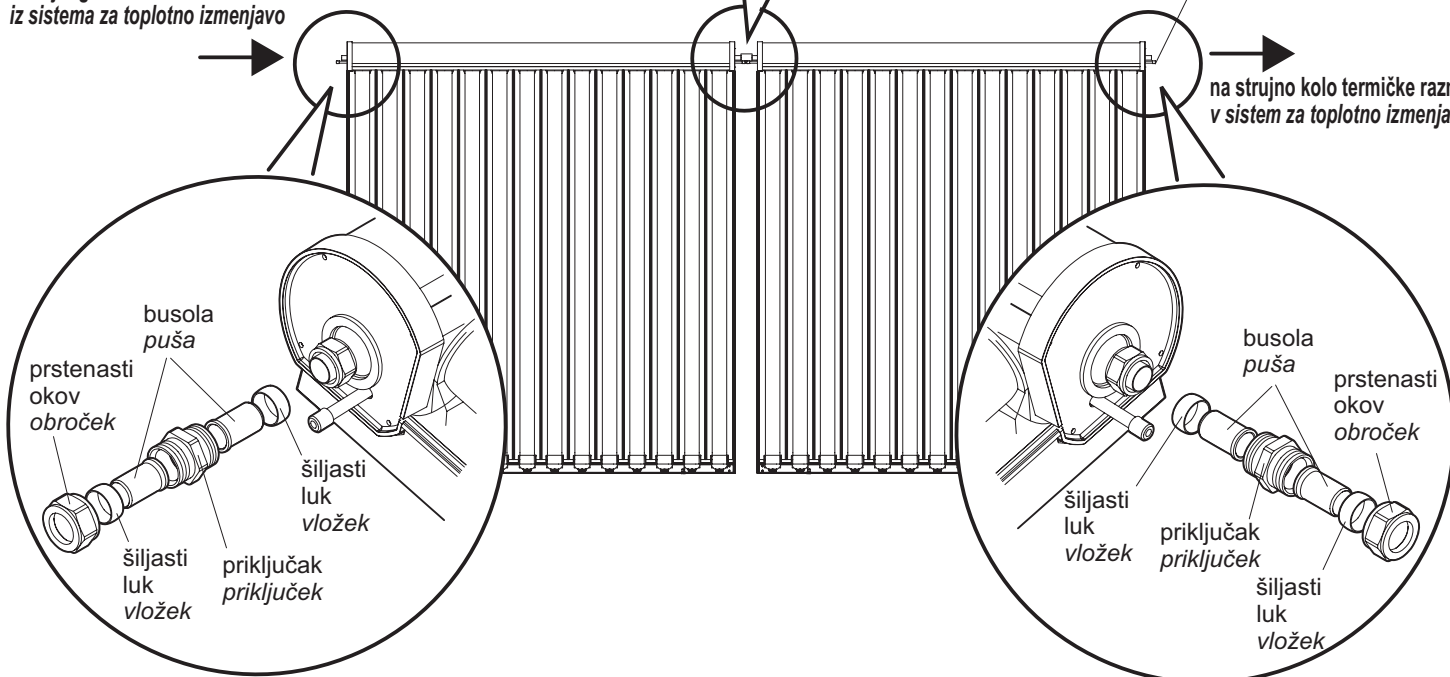

20027281 sa BAKARNOM CEVI Ø 18 mm
z BAKRENO CEVJO Ø 18 mm

OPREMA ZA PRIKLJUČAK KOMPLET PRIKLJUČKOV

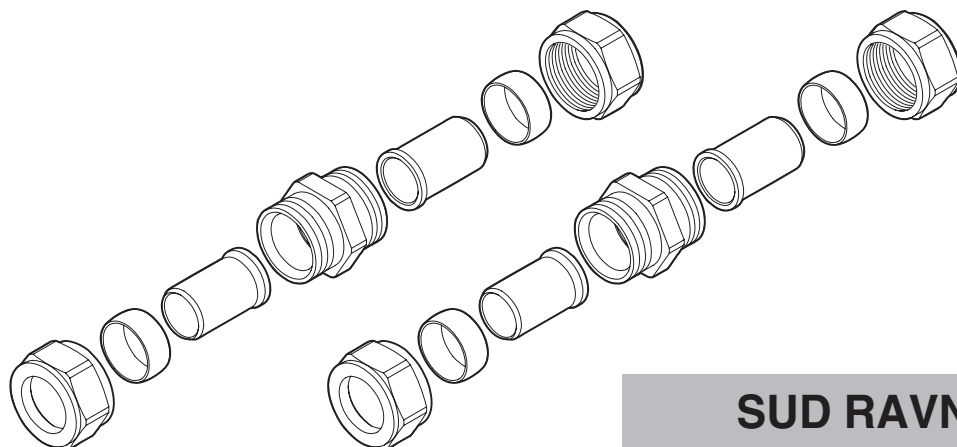

SUD RAVNI KOLEKTORA PLOSKI KOLEKTOR POSODE

