

## KIT STAFFAGGIO SOTTOTEGOLA REGOLABILE

ITALIANO ..... 3

ITALIANO

## ADJUSTABLE UNDER-TILE ROOF MOUNTING KIT

ENGLISH ..... 3

ENGLISH

## KIT POUR FIXATION SOUS-TUILE RÉGLABLE

FRANÇAIS ..... 14

FRANÇAIS

## BEFESTIGUNGSBAUSATZ FÜR EINSTELLBARE UNTERZIEGELMONTAGE

DEUTSCH ..... 14

DEUTSCH

## INTELBARE KIT VOOR BEVESTIGING ONDER DE DAKPAN

NEDERLANDS ..... 25

NEDERLANDS

## KIT DE DISPOSITIVOS DE FIJACIÓN REGULABLES BAJO LAS TEJAS

ESPAÑOL ..... 25

ESPAÑOL

## KIT DE SUPORTES AJUSTÁVEIS PARA FIXAÇÃO DEBAIXO DE TELHAS

PORTUGUÊS ..... 36

PORTUGUÊS

## REGULOWANY ZESTAW DO MOCOWANIA PODDACHÓWKOWEGO

POLISH ..... 36

POLISH

## OPREMA ZA MONTIRANJE ISPOD PODESIVOG CREPA

SRPSKI ..... 47

SRPSKI

## KOMPLET ZA PRILAGODLJIVO MONTAŽO POD STREŠNIKI

SLOVENŠČINA ..... 47

SLOVENŠČINA



# KIT STAFFAGGIO SOTTOTEGOLA REGOLABILE ADJUSTABLE UNDER-TILE ROOF MOUNTING KIT

ITALIANO

ENGLISH

Questa istruzione è parte integrante del libretto del collettore solare al quale si rimanda per le AVVERTENZE GENERALI e per le REGOLE FONDAMENTALI DI SICUREZZA.

*This instruction manual is an integral part of the installation and maintenance manual for the solar collector. Refer to that manual for GENERAL SAFETY INFORMATION AND PRECAUTIONS.*

**⚠** I collettori vanno installati esclusivamente con il kit di staffaggio ad essi relativo (che include gli accessori barre e di fissaggio) riportato a Listocatalogo, di cui il presente libretto descrive le istruzioni per il montaggio.  
*These solar collectors must be installed with a specific mounting kit (which includes all necessary rails and brackets) as listed in the catalogue. This manual describes the installation procedure.*

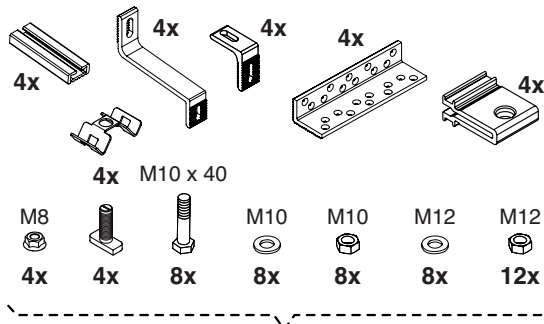

Sistema per il fissaggio al tetto (D)  
Roof fixing system (D)

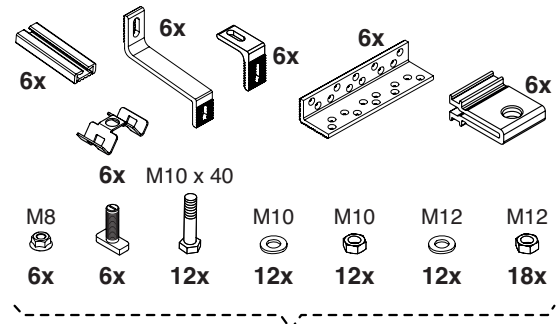

Sistema per il fissaggio al tetto (E)  
Roof fixing system (E)

Forniti separatamente arrivano:  
The following are supplied separately:

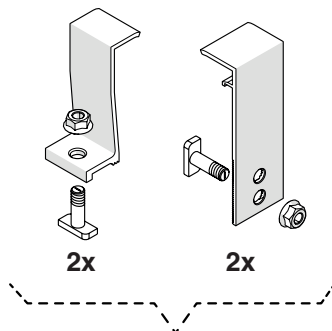

Kit bloccaggio collettori (H)  
Collector clamp kit (H)

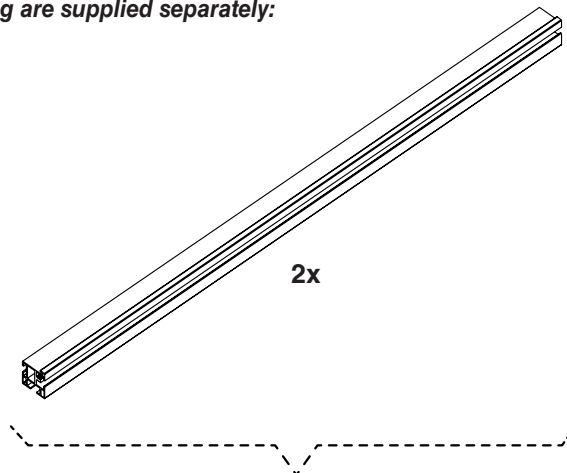

Barre di supporto (A-B-C)  
Support rails (A-B-C)

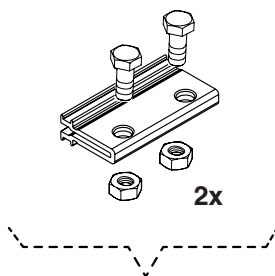

Giunti di accoppiamento (F)  
(se necessari)  
Connecting joints (F)  
(if needed)

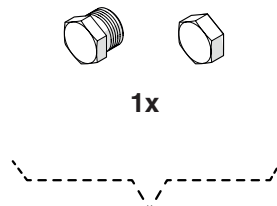

Kit terminali (G)  
End fittings kit (G)

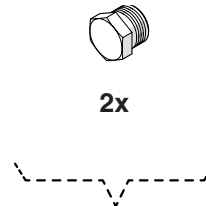

Kit terminali (L)  
End fittings kit (L)

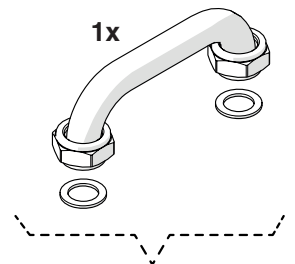

Raccordi di collegamento (I)  
Connecting pipes (I)

## Configurazioni possibili (verticale) Possible configurations (VERTICALLY MOUNTED collectors)

Nelle tabelle sono espresse le quantità e le tipologie di componenti da ordinare a seconda della configurazione di installazione scelta.

The table shows the quantity and type of components you need to order, depending on the configuration of the installation.

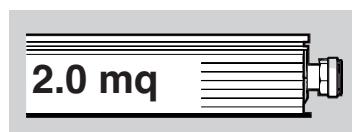

### Collettore 2.0 mq VERTICALE con TELAIO (4 attacchi G 1") 2.0 mq VERTICALLY MOUNTED COLLECTOR with FRAME (4xG 1" fittings)

COMPONENTI COMPONENTS			Numero collettori / Number of collectors					
			1	2	3	4	5	6
Barre di supporto Support rails	A	20087442	1x					
	B	20087443		1x		2x	1x	
	C	20087444			1x		1x	2x
Sistema di fissaggio / Fixing systems	D	20093051	1x	1x		2x	1x	
	E	20093052			1x		1x	2x
Giunti di accoppiamento / Connecting joints	F	20093048				1x	1x	1x
Kit raccordo terminali / End fittings kit	G	20094627	1x	1x	1x	1x	1x	1x
Kit bloccaggio collettori / Collector clamp kit	H	20093047	1x	2x	3x	4x	5x	6x

Tutti gli elementi a completamento dell'impianto sono disponibili nel listocatalogo al quale si rimanda per opportuna consultazione.

All the accessories required to complete installation of the system are available in the catalogue. Please refer to the catalogue for further details.

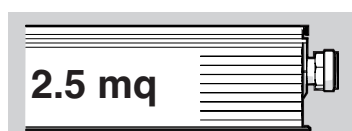

### Collettore 2.5 mq VERTICALE con TELAIO (2 attacchi G 1") 2.5 mq VERTICALLY MOUNTED COLLECTOR with FRAME (2xG 1" fittings)

COMPONENTI COMPONENTS			Numero collettori / Number of collectors					
			1	2	3	4	5	6
Barre di supporto Support rails	A	20087437	1x					
	B	20087438		1x		2x	1x	
	C	20087439			1x		1x	2x
Sistema di fissaggio / Fixing systems	D	20093051	1x	1x		2x	1x	
	E	20093052			1x		1x	2x
Giunti di accoppiamento / Connecting joints	F	20093048				1x	1x	1x
Kit bloccaggio collettori / Collector clamp kit	H	20093046	1x	2x	3x	4x	5x	6x

Tutti gli elementi a completamento dell'impianto sono disponibili nel listocatalogo al quale si rimanda per opportuna consultazione.

All the accessories required to complete installation of the system are available in the catalogue. Please refer to the catalogue for further details.

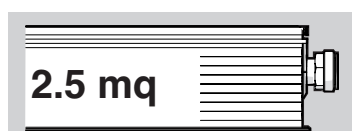

### Collettore 2.5 mq VERTICALE con TELAIO (4 attacchi G 1") 2.5 m<sup>2</sup> VERTICALLY MOUNTED COLLECTOR with FRAME (4xG 1" fittings)

COMPONENTI COMPONENTS			Numero collettori / Number of collectors					
			1	2	3	4	5	6
Barre di supporto Support rails	A	20087437	1x					
	B	20087438		1x		2x	1x	
	C	20087439			1x		1x	2x
Sistema di fissaggio / Fixing systems	D	20093051	1x	1x		2x	1x	
	E	20093052			1x		1x	2x
Giunti di accoppiamento / Connecting joints	F	20093048		1x	1x	1x	1x	1x
Kit raccordo terminali / End fittings kit	G	20094627	1x	1x	1x	1x	1x	1x
Kit bloccaggio collettori / Collector clamp kit	H	20093046	1x	2x	3x	4x	5x	6x

Tutti gli elementi a completamento dell'impianto sono disponibili nel listocatalogo al quale si rimanda per opportuna consultazione.

All the accessories required to complete installation of the system are available in the catalogue. Please refer to the catalogue for further details.

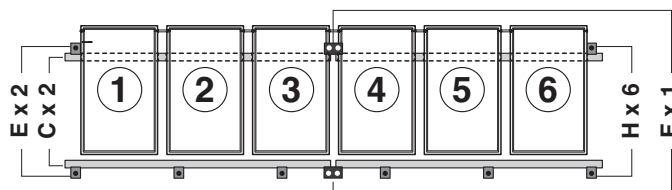
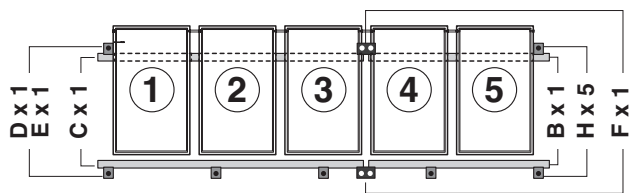
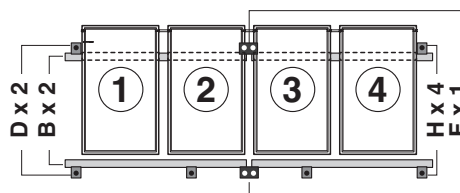
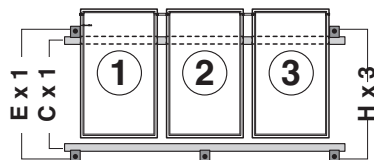
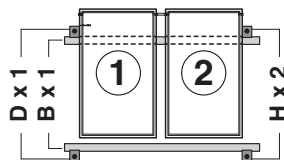
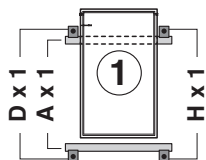

Nelle tabelle sono espresse le quantità e le tipologie di componenti da ordinare a seconda della configurazione di installazione scelta.

*The table shows the quantity and type of components you need to order, depending on the configuration of the installation.*

## Configurazioni possibili (orizzontale) Possible configurations (HORIZONTALLY MOUNTED collectors)

Nelle tabelle sono espresse le quantità e le tipologie di componenti da ordinare a seconda della configurazione di installazione scelta.

The table shows the quantity and type of components you need to order, depending on the configuration of the installation.

**2.5 mq**

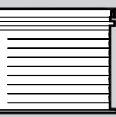

**Collettore 2.5 mq ORIZZONTALE con TELAIO (2 attacchi G 1")**  
**2.5 mq HORIZONTALLY MOUNTED COLLECTOR with FRAME (2xG 1" fittings)**

COMPONENTI COMPONENTS			Numero collettori / Number of collectors					
			1	2	3	4	5	6
Barre di supporto Support rails	A	20093053	1x		1x		1x	
	B	20093054		1x	1x	2x	2x	3x
Sistema di fissaggio / Fixing systems	D	20093051	1x		1x		1x	
	E	20093052		1x	1x	2x	2x	3x
Giunti di accoppiamento / Connecting joints	F	20093048			1x	1x	2x	2x
Kit bloccaggio collettori / Collector clamp kit	H	20093046	1x	2x	3x	4x	5x	6x
Raccordi di collegamento Collector connecting pipes	I	20094626		1x	2x	3x	4x	5x

Tutti gli elementi a completamento dell'impianto sono disponibili nel listocatalogo al quale si rimanda per opportuna consultazione.

All the accessories required to complete installation of the system are available in the catalogue. Please refer to the catalogue for further details.

**2.5 mq**

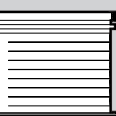

**Collettore 2.5 mq ORIZZONTALE con TELAIO (4 attacchi G 1")**  
**2.5 m<sup>2</sup> HORIZONTALLY MOUNTED COLLECTOR with FRAME (4xG 1" fittings)**

COMPONENTI COMPONENTS			Numero collettori / Number of collectors					
			1	2	3	4	5	6
Barre di supporto Support rails	A	20093053	1x		1x		1x	
	B	20093054		1x	1x	2x	2x	3x
Sistema di fissaggio / Fixing systems	D	20093051	1x	1x		2x	1x	
	E	20093052			1x		1x	2x
Giunti di accoppiamento / Connecting joints	F	20093048		1x	1x	1x	1x	1x
Kit raccordo terminali / End fittings kit	L	20134336	1x	2x	3x	4x	5x	6x
Kit bloccaggio collettori / Collector clamp kit	H	20093046	1x	2x	3x	4x	5x	6x
Raccordi di collegamento Collector connecting pipes	I	20094626	1x	2x	3x	4x	5x	6x

Tutti gli elementi a completamento dell'impianto sono disponibili nel listocatalogo al quale si rimanda per opportuna consultazione.

All the accessories required to complete installation of the system are available in the catalogue. Please refer to the catalogue for further details.

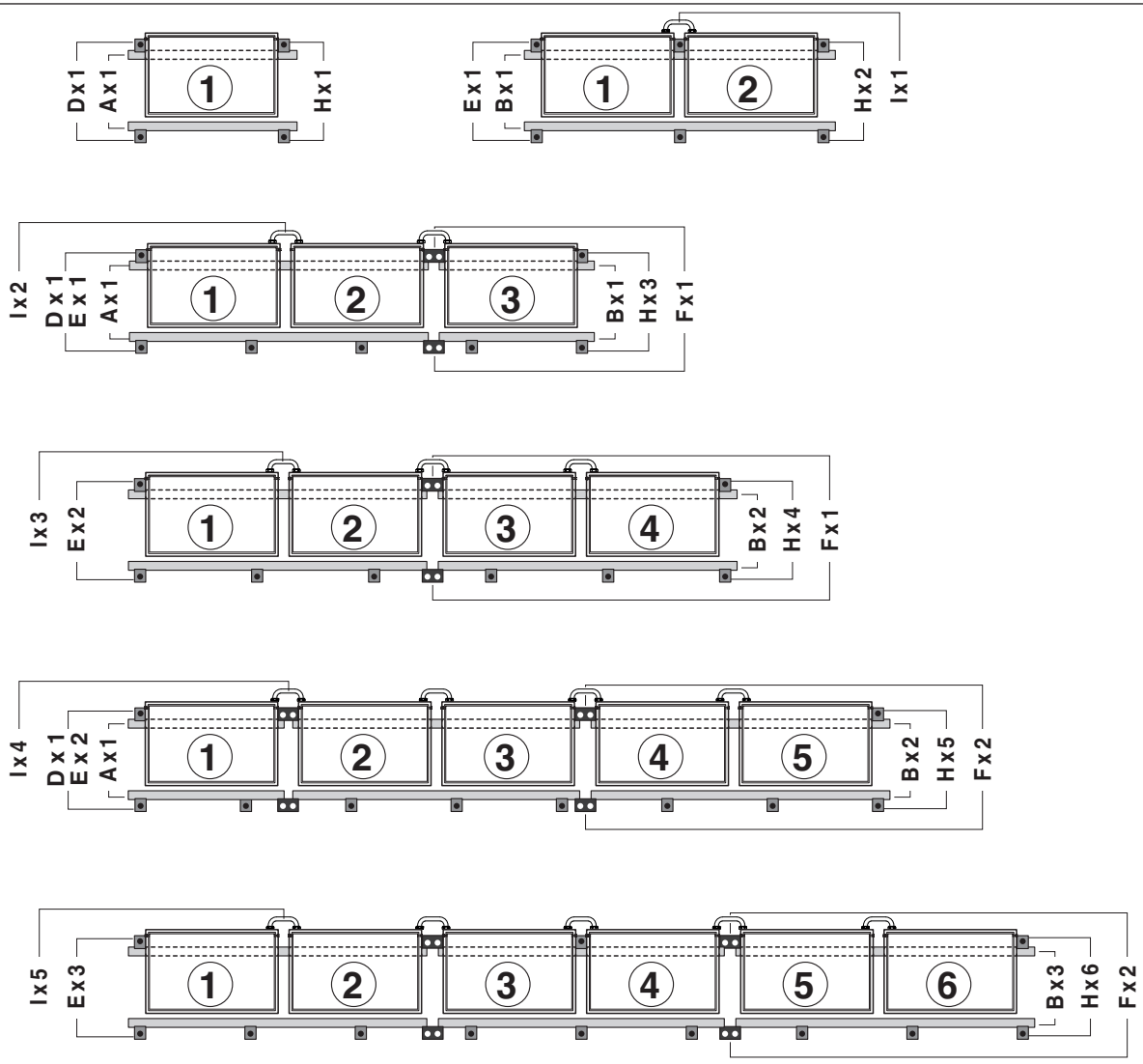

Nelle tabelle sono espresse le quantità e le tipologie di componenti da ordinare a seconda della configurazione di installazione scelta.  
 The table shows the quantity and type of components you need to order, depending on the configuration of the installation.

## Quote per il posizionamento del sistema di fissaggio (D-E) Dimensions for positioning of fixing system (D-E)

- ⚠ In presenza del giunto di accoppiamento tra barre, assicurare almeno un punto di fissaggio in prossimità del giunto stesso.  
*If a connecting joint is required between support rails, locate at least one fixing point near it.*
- ⚠ La dimensione H per il fissaggio delle viti sulle tegole, può essere regolata a seconda delle esigenze di montaggio.  
*Dimension H for fixing the screws to the roof tiles can be varied to meet the needs of the individual installation.*

Distribuire uniformemente gli altri punti di fissaggio lungo tutta la lunghezza.  
*Distribute the other fixing points uniformly along the complete length.*

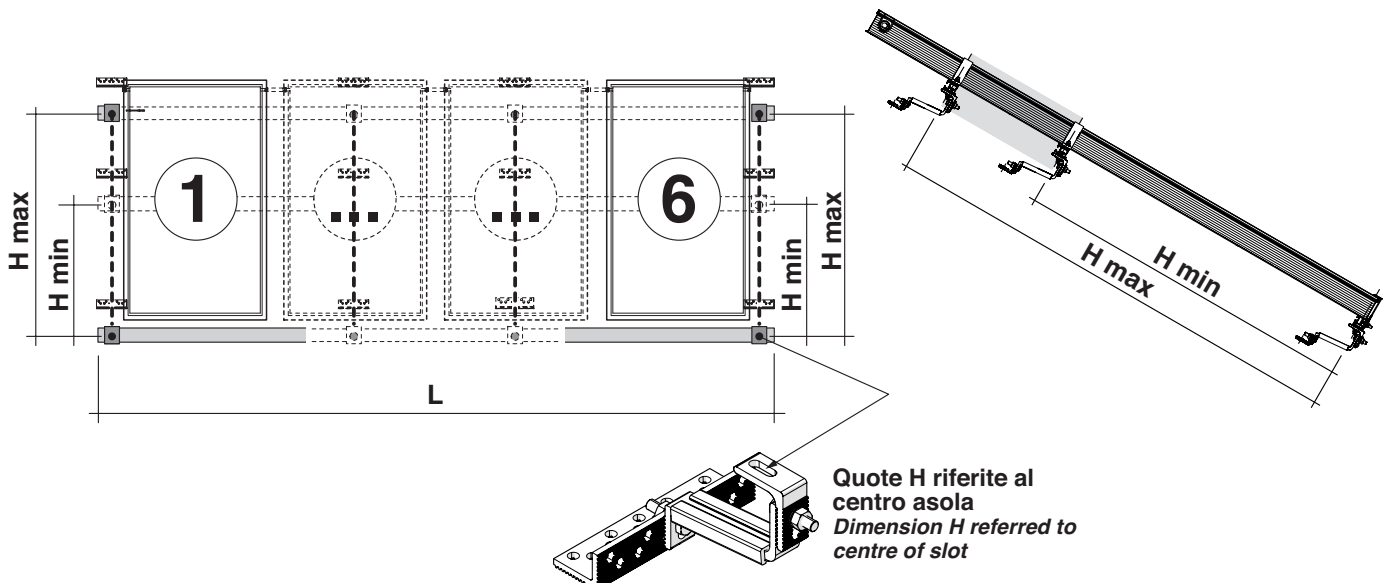

	Quota Dimension  H min - H max (in cm)	Numero collettori Number of collectors					
		1	2	3	4	5	6
		Lunghezza / Length L (in cm)					
Collettore 2.5 mq VERTICALE con TELAIO <i>2.5 m<sup>2</sup> collector, VERTICALLY MOUNTED with FRAME</i>	160 - 190	120	240	360	480	600	720
Collettore 2.0 mq VERTICALE con TELAIO <i>2.0 m<sup>2</sup> collector, VERTICALLY MOUNTED with FRAME</i>	145 - 170	110	220	330	440	550	660
Collettore 2.5 mq ORIZZONTALE con TELAIO <i>2.5 m<sup>2</sup> collector, HORIZONTALLY MOUNTED with FRAME</i>	90 - 110	210	420	630	840	1050	1260

## Sistema per il fissaggio al tetto (D) Roof fixing system (D)

**2**

Assemblare i componenti come indicato in figura. Ripetere i passi "1" e "2" per tutte le staffe presenti nel sistema di fissaggio.

Assemble the components as shown in the figure. Repeat steps "1" and "2" for all the brackets in the fixing system.

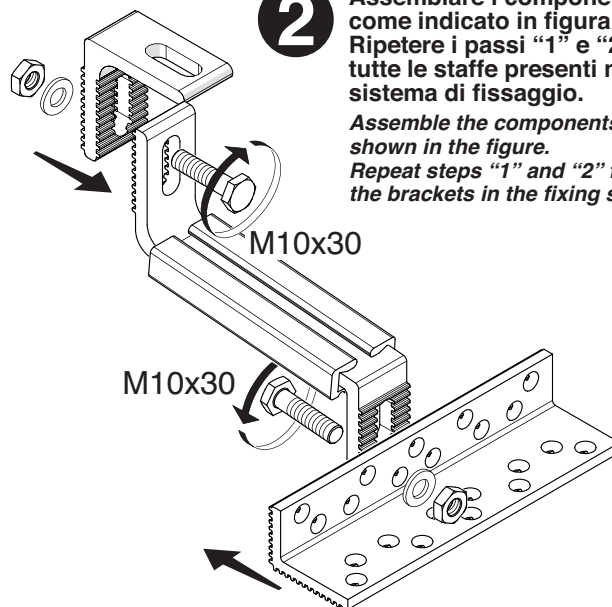
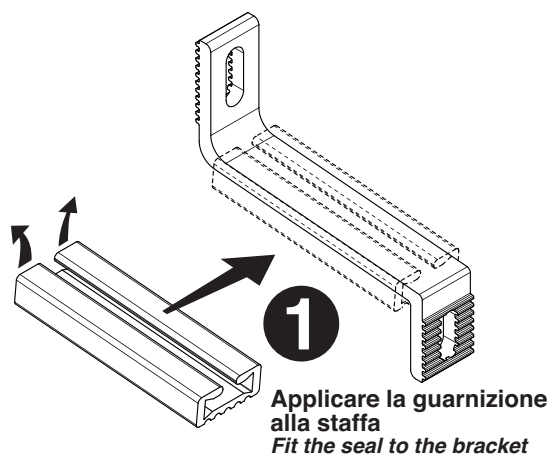

**3**

### RIMUOVERE / REMOVE

le tegole e posizionare, sulla PARTE CONCAVA DELLE TEGOLE, i sistemi di fissaggio "D" osservando, tra le asole "S", le quote "Hmin" e "Hmax" e quanto indicato negli schemi riportati alle pagine precedenti.

the tiles and position the fixing systems "D" on the CONCAVE SECTION OF THE TILES, maintaining dimensions "Hmin" e "Hmax" between the slots "S", as shown in the figures on the previous pages.

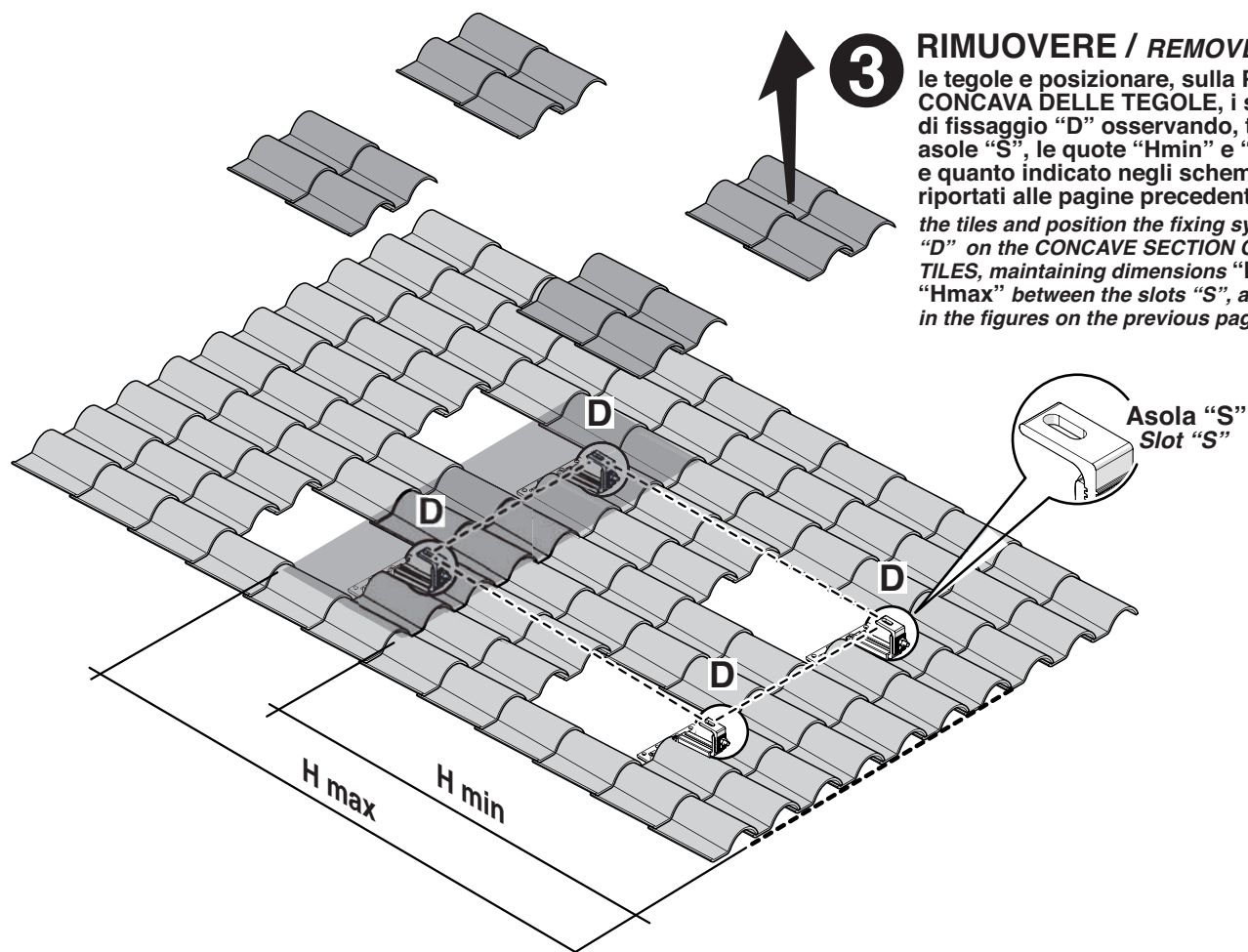

Calcolare la posizione del sistema di fissaggio in modo che la staffa ad L vada in appoggio alle tegole  
*Position the fixing system so that the L bracket rests securely on the tiles.*

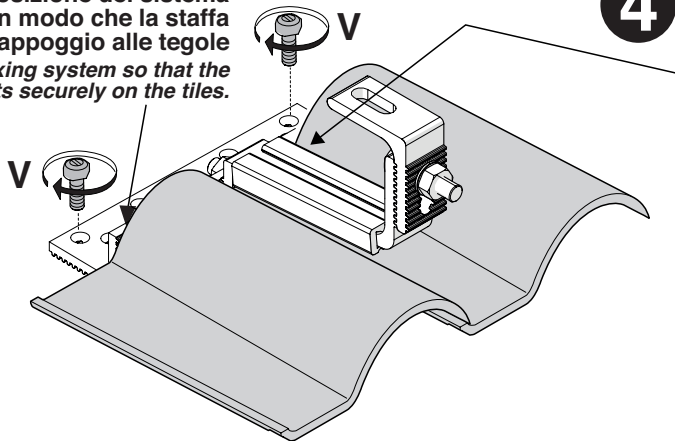

**4**

Far aderire perfettamente il sistema di fissaggio al tetto. Se necessario modellare leggermente la tegola.  
 Fissare al tetto le staffe (ogni staffa deve essere fissata in almeno due punti e deve esserne verificata la tenuta).  
 Le viti "V" NON SONO FORNITE e sono da prevedere in installazione a seconda delle caratteristiche del tetto.

*Make sure that the fixing system rests firmly on the roof. Shape the tile slightly if necessary. Fix the brackets to the roof. Secure each bracket at a minimum of two points, and check for tightness. The screws "V" are NOT SUPPLIED and must be provided on installation. Only use screws that are suitable for the characteristics of the roof.*



**LE TEGOLE NON VANNO ASSOLUTAMENTE FORATE.**

**DO NOT DRILL THE ROOF TILES UNDER ANY CIRCUMSTANCES.**

**5**

**RIPOSIZIONARE / REPOSITION**

le tegole rimosse in precedenza  
*the tiles removed previously*

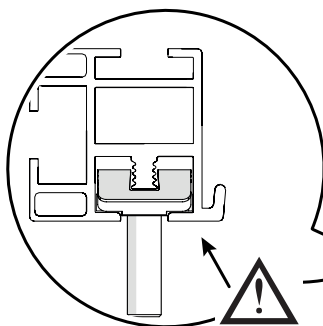
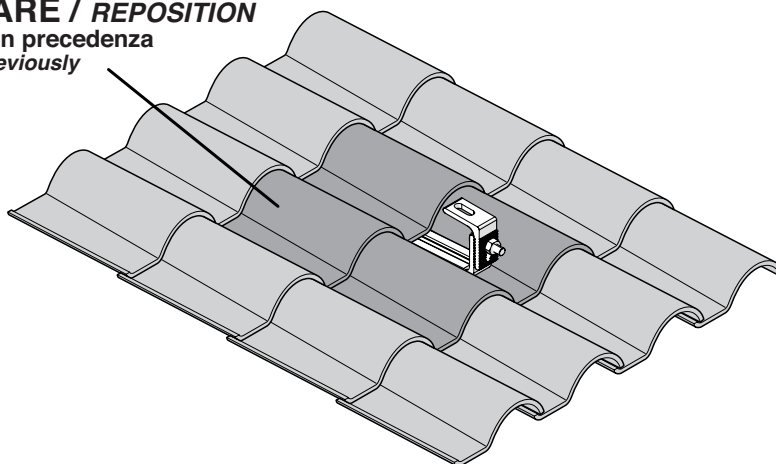

**6**

Inserire e far scorrere le viti a martello e relativa staffa blocca rotazione nelle barre di supporto superiori.

*Insert the rectangular head screws with their anti-rotation clips in the top support rails and slide them along.*

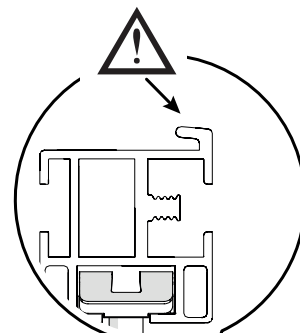

**6**

Inserire e far scorrere le viti a martello e relativa staffa blocca rotazione nelle barre di supporto inferiori.

*Insert the rectangular head screws with their anti-rotation clips in the bottom support rails and slide them along.*

**7**

Alto / Top  
 Basso / Bottom

**7**

**Giunti di accoppiamento (inseriti nel kit F), se presenti**  
(Forniti separatamente)  
**Connecting joints (F included in the kits), if present**  
(Supplied separately)

In presenza di più barre di supporto  
allinearle tra loro utilizzando i giunti  
di accoppiamento (F) e quindi  
bloccarle con le apposite viti.  
*If a number of support rails are needed,  
align them using the connecting joints  
(F) before fixing them in place with the  
screws provided.*

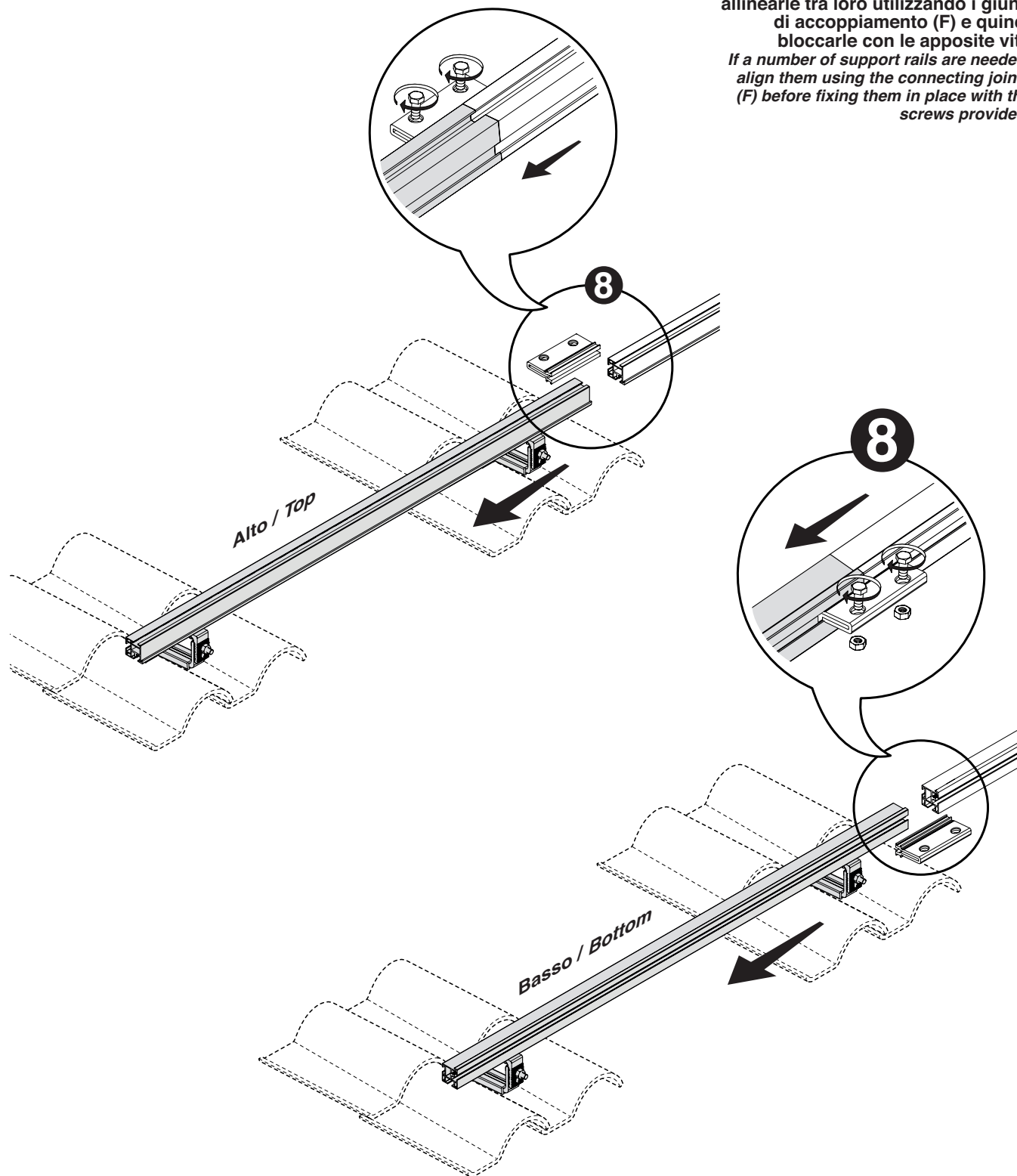

**Kit bloccaggio collettori (H)**  
**Kit bloccaggio collettori (H)**

**10a** Inserire / Insert

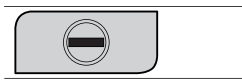

**10b** Ruotare 90° / Rotate 90°

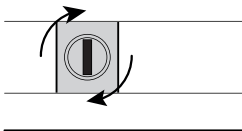

 Dopo il serraggio verificare che l'intaglio della vite sia in **POSIZIONE ORTOGONALE** rispetto alla disposizione della barra.  
*After tightening, check that the groove in the screw is **PERPENDICULAR** to the support rail.*

**10**

Posizionare le viti a testa rettangolare e fissare il collettore solare alle barre di supporto superiori utilizzando le graffe.  
*Insert the rectangular head screws and fix the solar collector to the top support rails using the clamps.*

**10**



Far coincidere i denti della staffa con quelli della cornice del collettore.  
*Engage the ridges on the clamp with the ridges on the frame of the collector.*

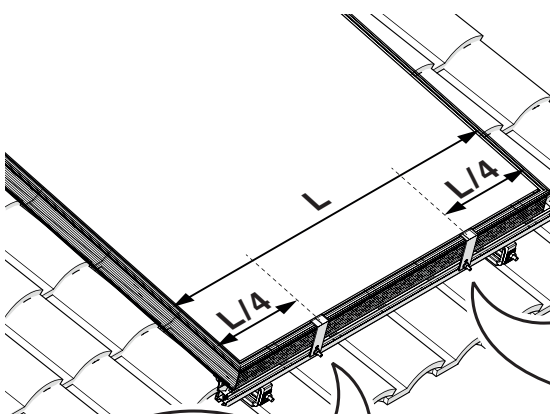

**9**

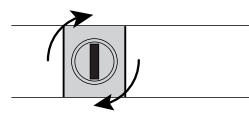

**11a**

**Pb** Ruotare 90° / Rotate 90°



-  Per collettore da 2 m<sup>2</sup>  
For 2 m<sup>2</sup> collector
-  Per collettore da 2,5 m<sup>2</sup>  
For 2,5 m<sup>2</sup> collector

**Pa** Inserire / Insert

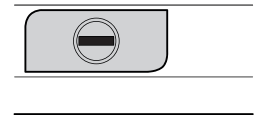

Posizionare le viti a testa rettangolare in posizione Pa nella barra di supporto inferiore e approntare la graffa sulla vite.  
*Arrange the rectangular head screws in position Pa in the bottom support rail and fit the brackets over them.*



Dopo il serraggio verificare che l'intaglio della vite sia in **POSIZIONE ORTOGONALE** rispetto alla disposizione della barra.  
*After tightening, check that the groove in the screw is **PERPENDICULAR** to the support rail.*

Inserire la graffa sul profilo del collettore ruotandola leggermente.  
 Ruotare la vite a testa rettangolare in posizione Pb e fissare il dado alla vite.  
*Rotate the bracket gently to engage it with the profile of the collector. Turn the rectangular head screws into position Pb and tighten the nut.*



Dopo il fissaggio del collettore la graffa non deve appoggiare sul vetro del collettore. È normale che vi sia una distanza di qualche mm tra la graffa e il vetro del collettore. *Make sure that after fixing the clamp does not rest on the glass of the collector. There should always be a gap of a couple of mm between the clamp and the collector glass.*

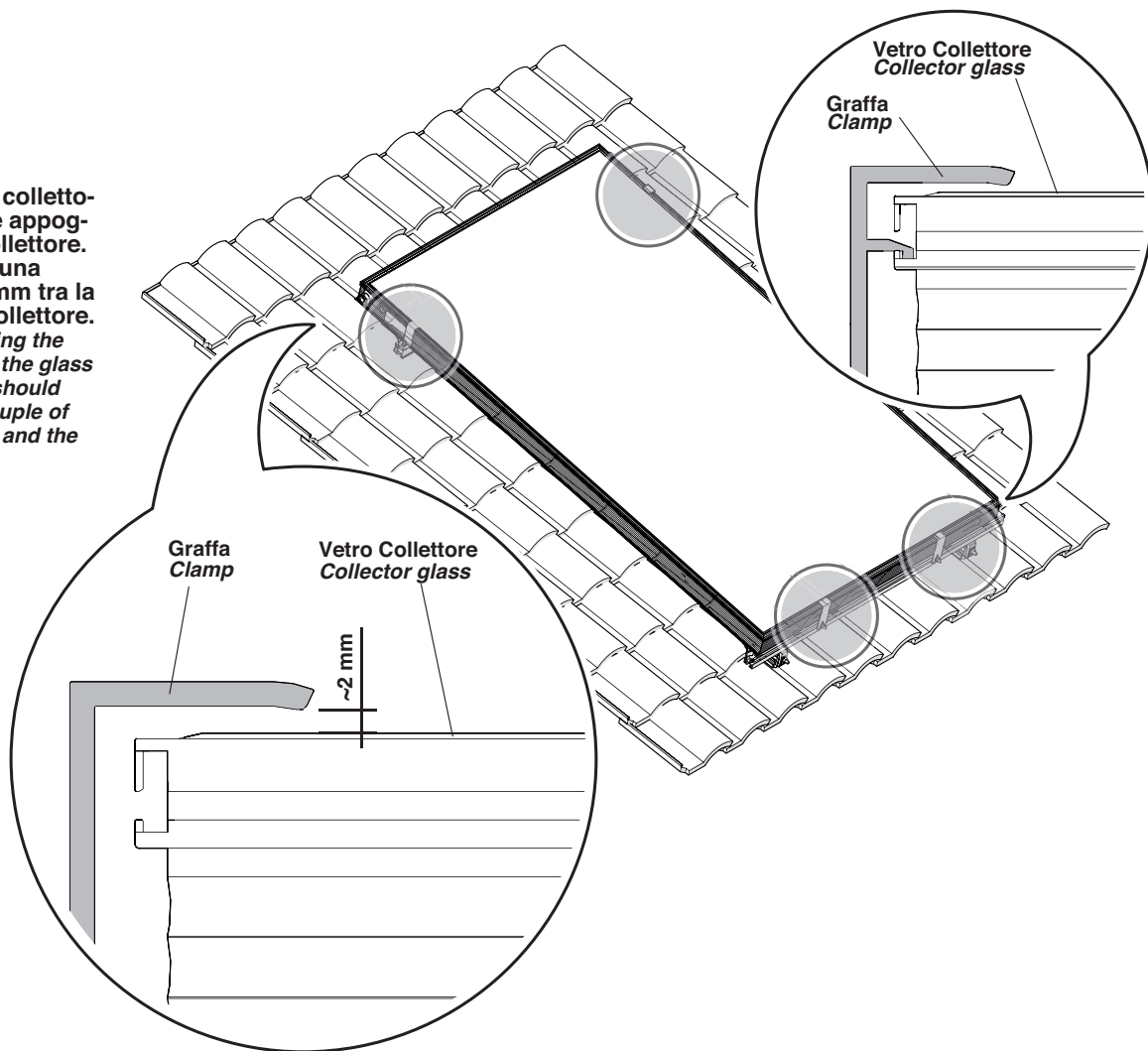

Nel caso di più collettori ripetere quanto descritto ai punti 9 - 11 per ciascun collettore. *In multi-collector installations, repeat steps 9 and 11 for each collector.*

**12**

Collegare tra di loro i collettori serrando i raccordi idraulici con una coppia adeguata. *Connect the collectors together, tightening the water fittings to a suitable torque.*

UTILIZZARE IL SISTEMA CHIAVE-CONTROCHIAVE per non danneggiare l'assorbitore.

*When tightening a fitting, HOLD THE OPPOSITE FITTING STEADY WITH A SECOND TOOL to avoid damage.*

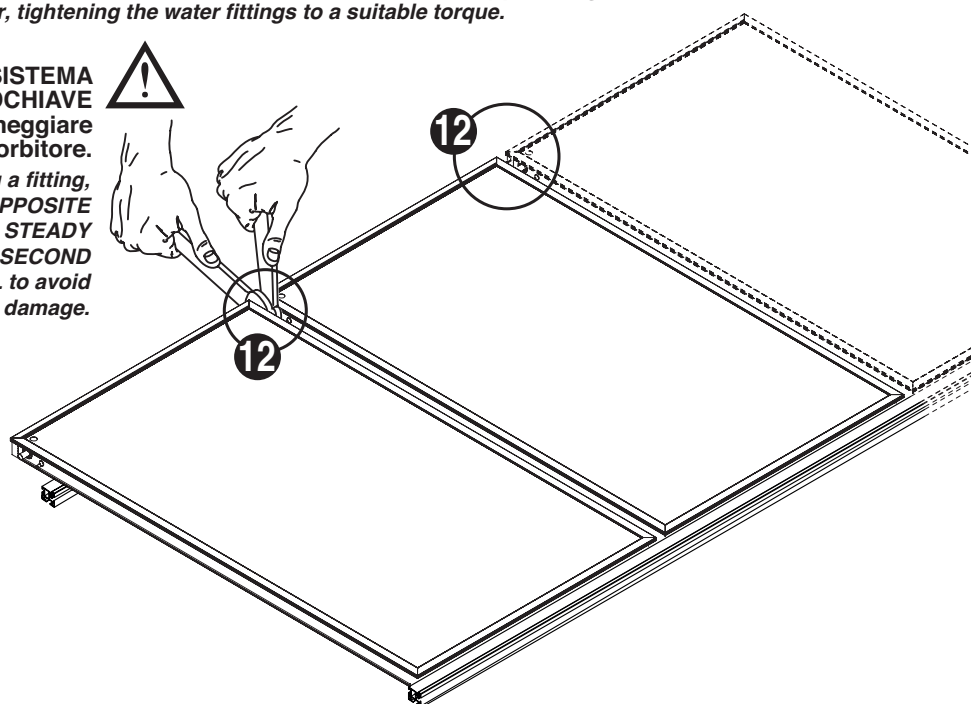

# KIT POUR FIXATION SOUS-TUILE RÉGLABLE BEFESTIGUNGSBAUSATZ FÜR EINSTELLBARE UNTERZIEGELMONTAGE

Ces instructions font partie intégrante de la notice du capteur solaire. Consulter cette notice pour les AVERTISSEMENTS GÉNÉRAUX et pour les RÈGLES FONDAMENTALES DE SÉCURITÉ.

Diese Anleitung ist wesentlicher Bestandteil der Kollektordokumentation, worauf für die ALLGEMEINEN HINWEISE und die GRUNDLEGENDEN SICHERHEITSGESAMEN VERWIESEN WIRD.

**⚠** Les capteurs ne doivent être installés qu'avec le kit de fixation correspondant (comportant les rails et les accessoires de fixation), qui figure dans le Catalogue et dont la présente notice fournit les instructions de montage.  
Die Installation der Kollektoren hat unbedingt mit dem im Katalog angegebenen entsprechenden Befestigungsbausatz (in dem Stützleisten und Befestigungszubehör enthalten sind) und nach den Montageanweisungen dieser Anleitung zu erfolgen.

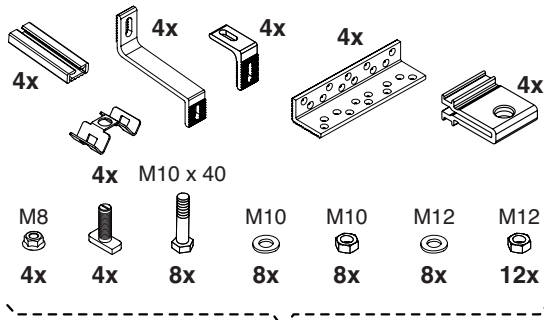

Système de fixation au toit (D)  
Dach-Befestigungssystem (D)

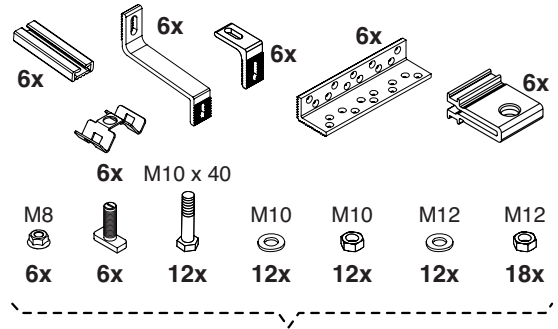

Système de fixation au toit (E)  
Dach-Befestigungssystem (E)

Éléments fournis séparément:  
Separat werden folgende Teile geliefert:

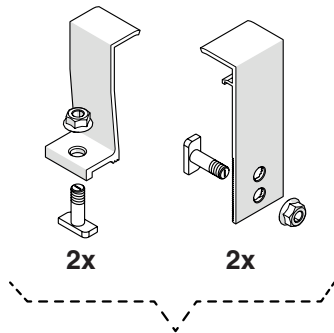

Kit de blocage des capteurs (H)  
Satz Kollektor-Klemmbügel (H)

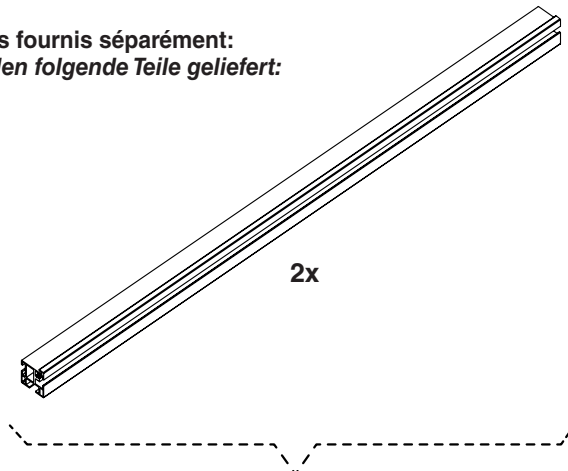

Rails de support (A-B-C)  
Stützleisten (A-B-C)

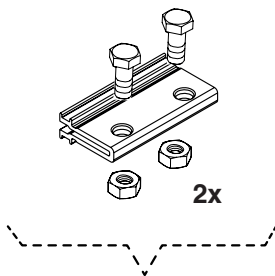

Pièces de liaisons (E) (si nécessaires)  
Verbindungsblaschen (F) (sofern erforderlich)

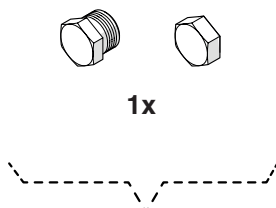

Kit de terminaisons (G)  
Satz Endanschlüsse (G)

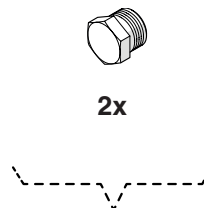

Kit de terminaisons (L)  
Satz Endanschlüsse (L)

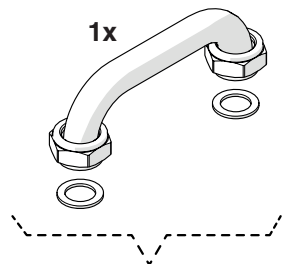

Raccords de liaisons (I)  
Anschaltanschlüsse (I)

## Configurations possibles (verticale) Konfigurationsmöglichkeiten (senkrecht)

Les tableaux ci-dessous indiquent les quantités et les types de composants à commander selon la configuration d'installation.  
In den Tabellen finden Sie Anzahl und Art der je nach gewünschter Installationskonfiguration zu bestellenden Komponenten.

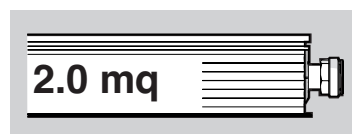

### Capteur 2,0 m<sup>2</sup> VERTICAL avec CHÂSSIS (4 raccords G 1") SENKRECHTER 2.0 qm Kollektor mit RAHMEN (4 Anschlüsse G 1")

COMPOSANTS KOMPONENTEN			Nombre de capteurs / Anzahl von Kollektoren					
			1	2	3	4	5	6
Rails de support Stützleisten	A	20087442	1x					
	B	20087443		1x		2x	1x	
	C	20087444			1x		1x	2x
Système de fixation / Befestigungssystem	D	20093051	1x	1x		2x	1x	
	E	20093052			1x		1x	2x
Pièces de liaison / Verbindungsglaschen	F	20093048				1x	1x	1x
Kit de raccords terminaux / Bausatz Endanschlüsse	G	20094627	1x	1x	1x	1x	1x	1x
Kit de blocage des capteurs / Satz Kollektor-Klemmbügel	H	20093047	1x	2x	3x	4x	5x	6x

Tous les éléments permettant de compléter l'installation sont disponibles dans le catalogue. Consulter ce dernier pour de plus amples détails.  
Für die zur Fertigstellung der Anlage verfügbaren Elemente wird auf den Preislistenkatalog verwiesen.



### Capteur 2,5 m<sup>2</sup> VERTICAL avec CHÂSSIS (2 raccords G 1") SENKRECHTER 2.5 qm Kollektor mit RAHMEN (2 Anschlüsse G 1")

COMPOSANTS KOMPONENTEN			Nombre de capteurs / Anzahl von Kollektoren					
			1	2	3	4	5	6
Rails de support Stützleisten	A	20087437	1x					
	B	20087438		1x		2x	1x	
	C	20087439			1x		1x	2x
Système de fixation / Befestigungssystem	D	20093051	1x	1x		2x	1x	
	E	20093052			1x		1x	2x
Pièces de liaison / Verbindungsglaschen	F	20093048				1x	1x	1x
Kit de blocage des capteurs / Satz Kollektor-Klemmbügel	H	20093046	1x	2x	3x	4x	5x	6x

Tous les éléments permettant de compléter l'installation sont disponibles dans le catalogue. Consulter ce dernier pour de plus amples détails.  
Für die zur Fertigstellung der Anlage verfügbaren Elemente wird auf den Preislistenkatalog verwiesen.

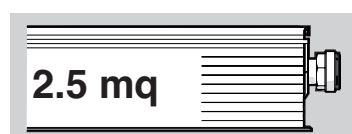

### Capteur 2.5 m<sup>2</sup> VERTICAL avec CHÂSSIS (4 raccords G 1") SENKRECHTER 2.5 qm Kollektor mit RAHMEN (4 Anschlüsse G 1")

COMPOSANTS KOMPONENTEN			Nombre de capteurs / Anzahl von Kollektoren					
			1	2	3	4	5	6
Rails de support Stützleisten	A	20087437	1x					
	B	20087438		1x		2x	1x	
	C	20087439			1x		1x	2x
Système de fixation / Befestigungssystem	D	20093051	1x	1x		2x	1x	
	E	20093052			1x		1x	2x
Pièces de liaison / Verbindungsglaschen	F	20093048		1x	1x	1x	1x	1x
Kit de raccords terminaux / Bausatz Endanschlüsse	G	20094627	1x	1x	1x	1x	1x	1x
Kit de blocage des capteurs / Satz Kollektor-Klemmbügel	H	20093046	1x	2x	3x	4x	5x	6x

Tous les éléments permettant de compléter l'installation sont disponibles dans le catalogue. Consulter ce dernier pour de plus amples détails.  
Für die zur Fertigstellung der Anlage verfügbaren Elemente wird auf den Preislistenkatalog verwiesen.

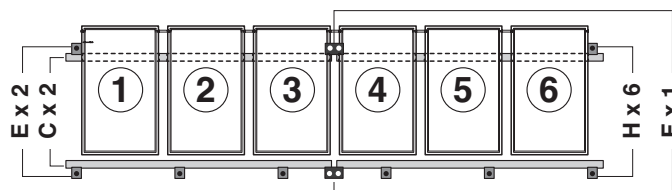
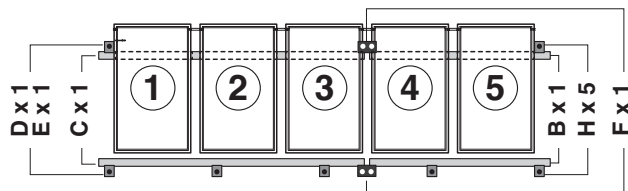
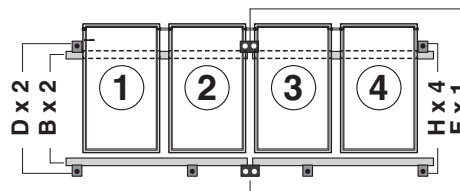
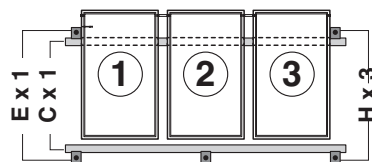
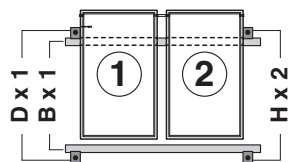
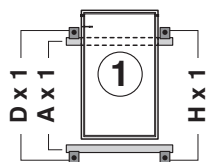

Les tableaux ci-dessous indiquent les quantités et les types de composants à commander selon la configuration d'installation.  
 In den Tabellen finden Sie Anzahl und Art der je nach gewünschter Installationskonfiguration zu bestellenden Komponenten.

## Configurations possibles (horizontale) Konfigurationsmöglichkeiten (waagrecht)

Les tableaux ci-dessous indiquent les quantités et les types de composants à commander selon la configuration d'installation.  
In den Tabellen finden Sie Anzahl und Art der je nach gewünschter Installationskonfiguration zu bestellenden Komponenten.

**2.5 mq**

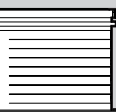

**Capteur 2,5 m<sup>2</sup> HORIZONTAL avec CHÂSSIS (2 raccords G 1")**  
**WAAGRECHTER 2.5 qm Kollektor mit RAHMEN (2 Anschlüsse G 1")**

COMPOSANTS KOMPONENTEN			Nombre de capteurs / Anzahl von Kollektoren					
			1	2	3	4	5	6
Rails de support <i>Stützleisten</i>	A	20093053	1x		1x		1x	
	B	20093054		1x	1x	2x	2x	3x
Système de fixation / <i>Befestigungssystem</i>	D	20093051	1x		1x		1x	
	E	20093052		1x	1x	2x	2x	3x
Pièces de liaison / <i>Verbindungsflaschen</i>	F	20093048			1x	1x	2x	2x
Kit de blocage des capteurs / <i>Satz Kollektor-Klemmbügel</i>	H	20093046	1x	2x	3x	4x	5x	6x
Raccords de liaison / <i>Anschaltanschlüsse</i>	I	20094626		1x	2x	3x	4x	5x

Tous les éléments permettant de compléter l'installation sont disponibles dans le catalogue. Consulter ce dernier pour de plus amples détails.  
Für die zur Fertigstellung der Anlage verfügbaren Elemente wird auf den Preislistenkatalog verwiesen.

**2.5 mq**

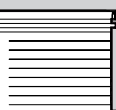

**Capteur 2.5 m<sup>2</sup> HORIZONTAL avec CHÂSSIS (4 raccords G 1")**  
**WAAGRECHTER 2.5 qm Kollektor mit RAHMEN (4 Anschlüsse G 1")**

COMPOSANTS KOMPONENTEN			Nombre de capteurs / Anzahl von Kollektoren					
			1	2	3	4	5	6
Rails de support <i>Stützleisten</i>	A	20093053	1x		1x		1x	
	B	20093054		1x	1x	2x	2x	3x
Système de fixation / <i>Befestigungssystem</i>	D	20093051	1x	1x		2x	1x	
	E	20093052			1x		1x	2x
Pièces de liaison / <i>Verbindungsflaschen</i>	F	20093048		1x	1x	1x	1x	1x
Kit de raccords terminaux / <i>Bausatz Endanschlüsse</i>	L	20134336	1x	2x	3x	4x	5x	6x
Kit de blocage des capteurs / <i>Satz Kollektor-Klemmbügel</i>	H	20093046	1x	2x	3x	4x	5x	6x
Raccords de liaison / <i>Anschaltanschlüsse</i>	I	20094626	1x	2x	3x	4x	5x	6x

Tous les éléments permettant de compléter l'installation sont disponibles dans le catalogue. Consulter ce dernier pour de plus amples détails.  
Für die zur Fertigstellung der Anlage verfügbaren Elemente wird auf den Preislistenkatalog verwiesen.

FRANÇAIS

DEUTSCH

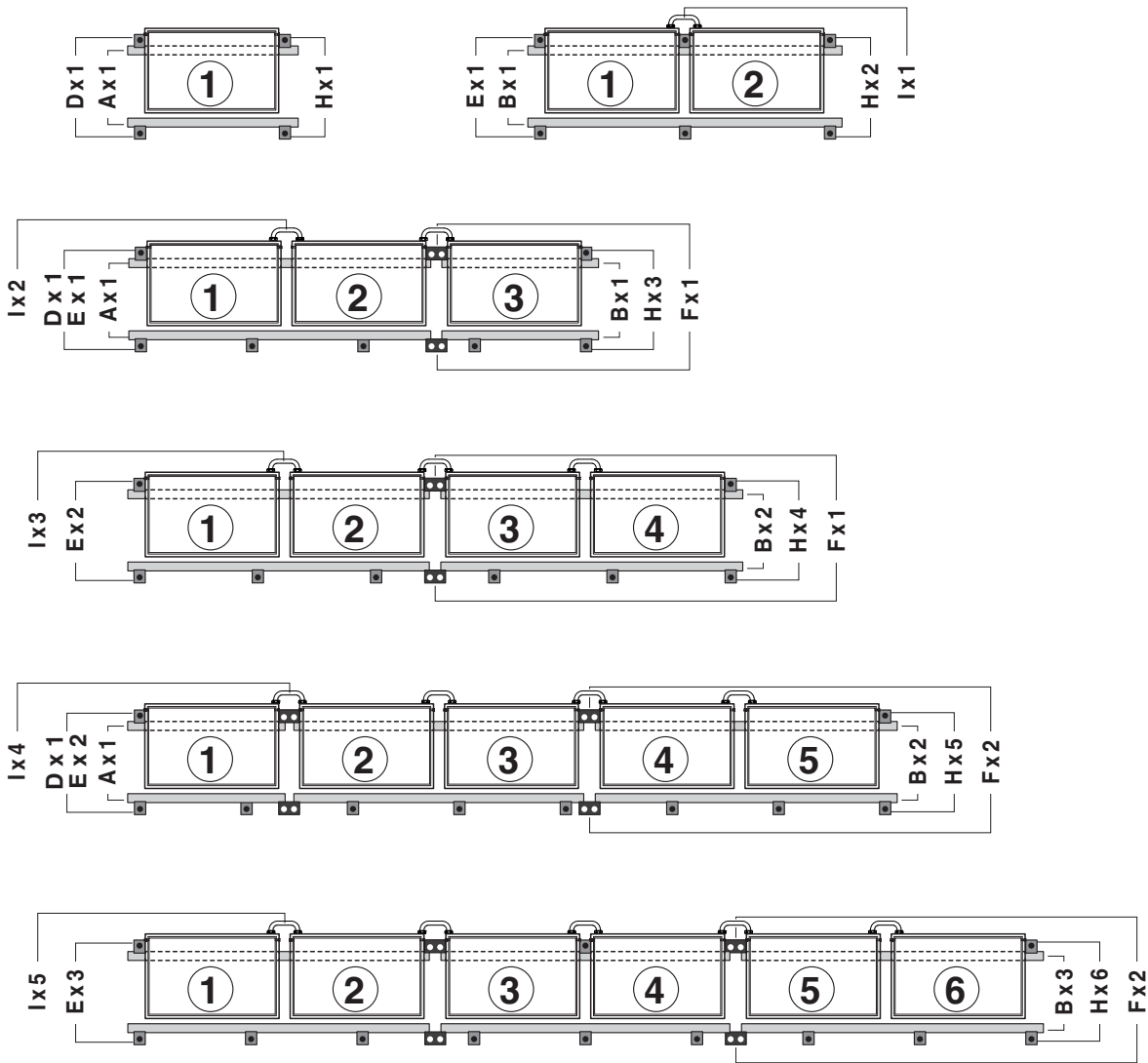

Les tableaux ci-dessous indiquent les quantités et les types de composants à commander selon la configuration d'installation.  
 In den Tabellen finden Sie Anzahl und Art der je nach gewünschter Installationskonfiguration zu bestellenden Komponenten.

## Mesures pour le positionnement du système de fixation (D-E) Einbaumaße des Befestigungssystems (D-E)

- ⚠ En présence d'une pièce de liaison entre deux rails, garantir au moins un point de fixation à proximité de cette pièce.  
*Bei einer Verbindungslasche zwischen den Stützleisten mindestens einen Befestigungspunkt in der Nähe der Lasche einrichten.*
- ⚠ La dimension H pour la fixation des vis sur les tuiles peut être réglée en fonction des exigences de montage.  
*Das Maß H für die Befestigung der Schrauben an den Ziegeln kann entsprechend den Montagebedürfnissen gewählt werden.*

Distribuer uniformément les autres points de fixation sur toute la longueur.  
*Die anderen Befestigungspunkte gleichförmig auf der gesamten Länge verteilen.*

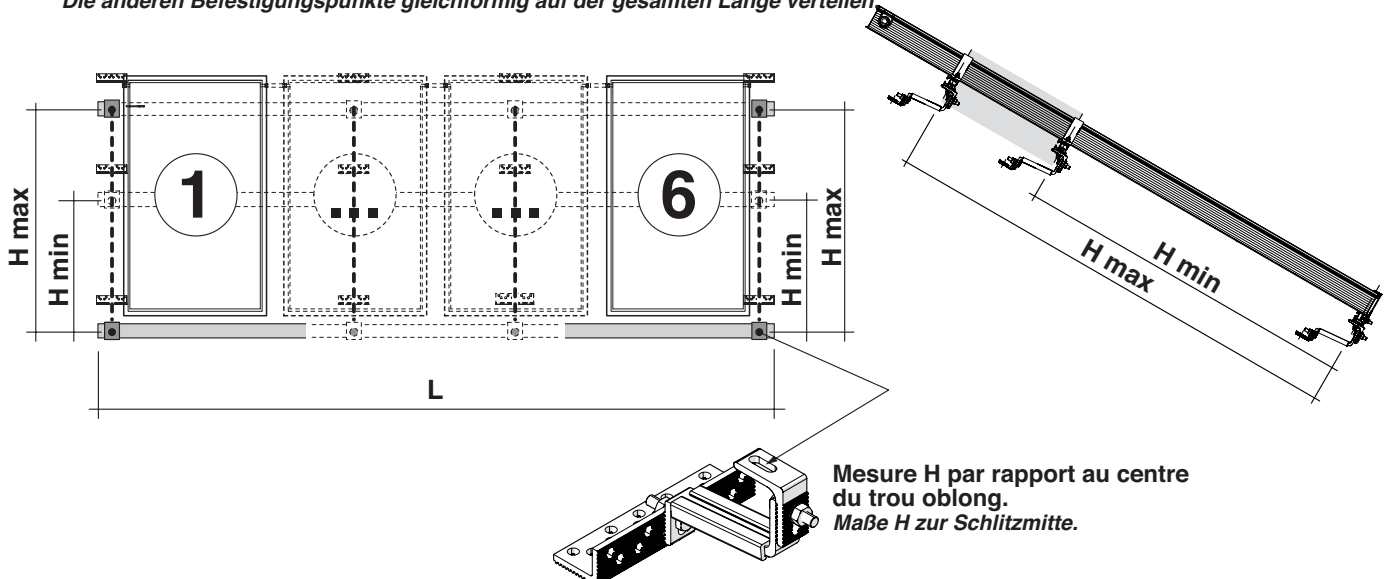

	Mesure Maß H min - H max (in/en cm)	Nombre de capteurs Anzahl von Kollektoren					
		1	2	3	4	5	6
		Longueur / Länge L (in/en cm)					
Capteur 2,5 m <sup>2</sup> VERTICAL avec CHÂSSIS <i>SENKRECHTER 2,5 qm Kollektor mit RAHMEN</i>	160 - 190	120	240	360	480	600	720
Capteur 2,0 m <sup>2</sup> VERTICAL avec CHÂSSIS <i>SENKRECHTER 2,0 qm Kollektor mit RAHMEN</i>	145 - 170	110	220	330	440	550	660
Capteur 2,5 m <sup>2</sup> HORIZONTAL avec CHÂSSIS <i>WAAGRECHTER 2.5 qm Kollektor mit RAHMEN</i>	90 - 110	210	420	630	840	1050	1260

FRANÇAIS

DEUTSCH

## Montage / Einbau

### Systeme de fixation au toit (D) Dach-Befestigungssystem (D)

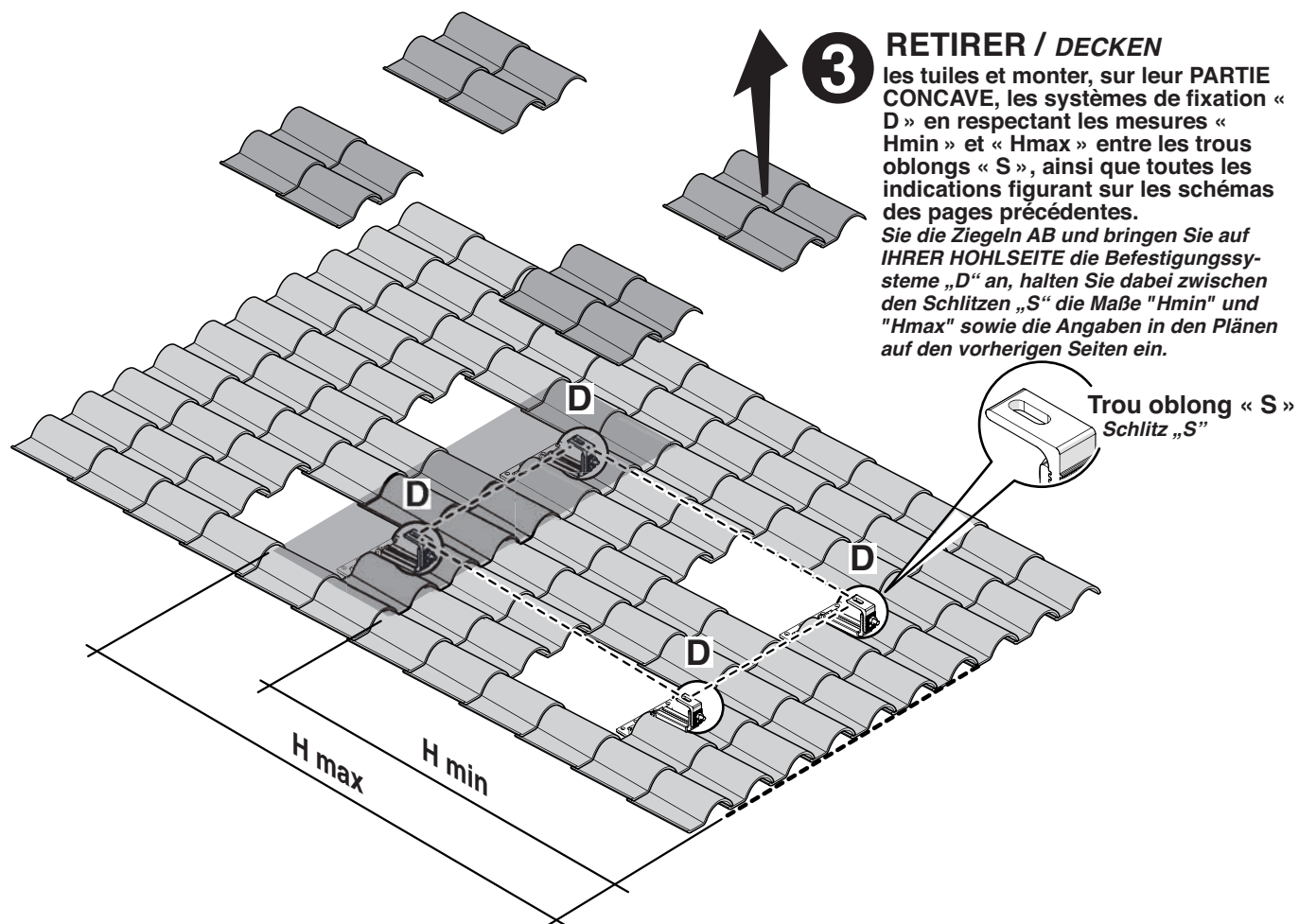
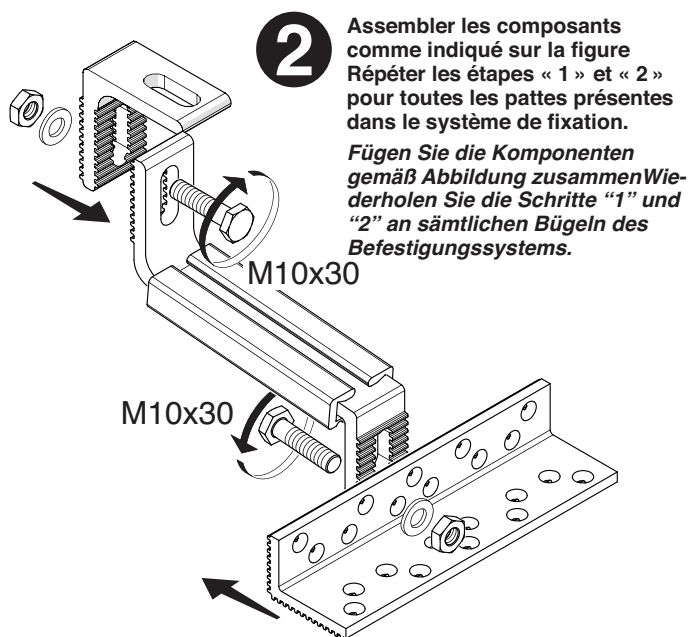
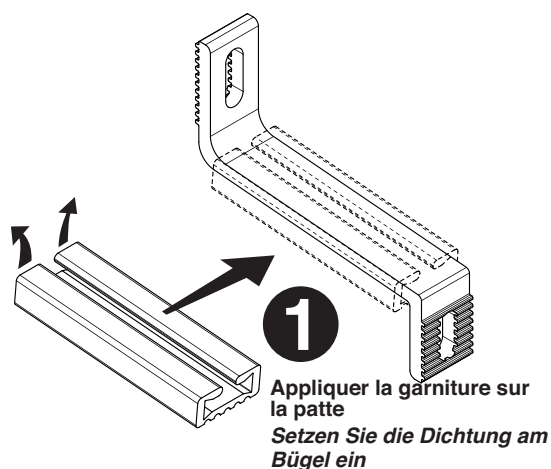

Calculer la position du système de fixation de manière à ce que la patte en L vienne contre les tuiles.

Berechnen Sie die Einbauposition des Befestigungssystems dahingehend, dass der L-förmige Bügel auf den Ziegeln zur Auflage kommt

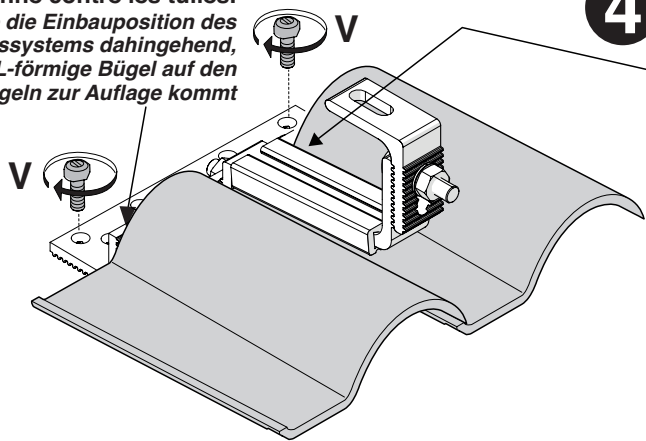

**4**

Fixer les pattes sur le toit (chaque patte doit avoir au moins deux points de fixation et sa bonne tenue doit être vérifiée). Les vis « V » NE SONT PAS FOURNIES et doivent être prévues dans l'installation selon les caractéristiques du toit. Faire adhérer parfaitement le système de fixation au toit. Si nécessaire, modeler légèrement la tuile.

Befestigen Sie die Bügel am Dach (jeder Bügel muss an mindestens 2 Punkten befestigt und auf Dichtigkeit überprüft werden). Die „V“ Schrauben SIND NICHT BEIGESTELLT und müssen daher bei Installation je nach Eigenschaften des Dachs bereitgestellt werden. Das Befestigungssystem muss bündig am Dach anliegen. Passen Sie bei Bedarf den Ziegel leicht an.



**LES TILES NE DOIVENT ABSOLUMENT PAS ÊTRE PERCÉES.**

**BOHREN SIE DIE ZIEGEL UNTER KEINEN MSTRÄNDEN.**

**5**

**REMETTRE EN PLACE / SETZEN**

les tuiles précédemment enlevées.  
sie die vorab abgenommenen Ziegel wieder auf

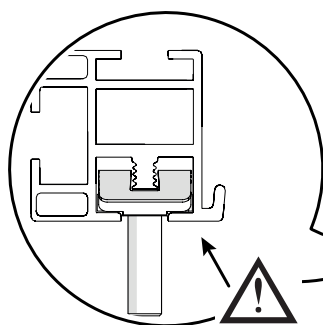
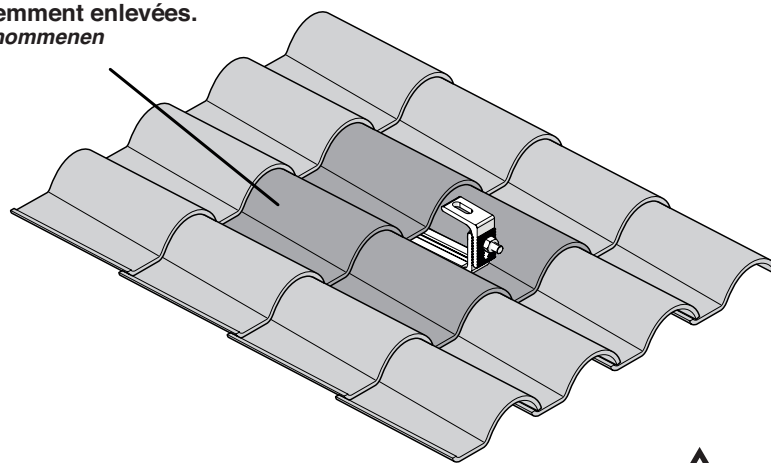

**6**

Insérer et faire glisser les vis à tête marteau et la patte correspondante de blocage de la rotation dans les rails de support supérieurs.

Setzen Sie die Hammerschrauben und den entsprechenden Drehschutzbügel in die oberen Stützleisten ein und verschieben Sie diese darin.

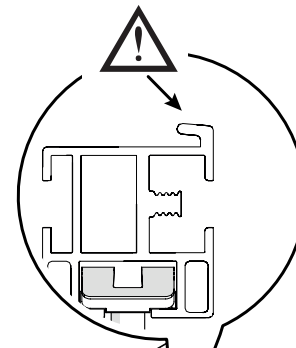

**6**

Insérer et faire glisser les vis à tête marteau et la patte correspondante de blocage de la rotation dans les rails de support inférieurs. Setzen Sie die Hammerschrauben und den entsprechenden Drehschutzbügel in die unteren Stützleisten ein und verschieben Sie diese darin.

**7**

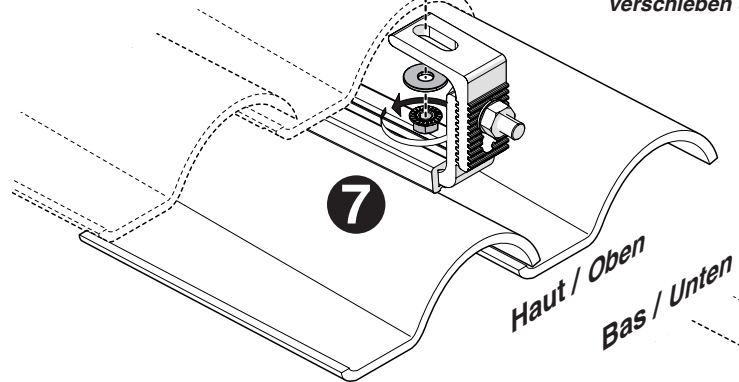

**7**

Haut / Oben  
Bas / Unten

**Pièces de liaison (incluses dans le kit F), si présentes**

(Fournies séparément)

**Verbindungsblaschen (im Bausatz F enthalten), sofern vorhanden**

(Separat geliefert)

Si plusieurs rails de support sont nécessaires, les aligner en utilisant les pièces de liaison (F), puis les bloquer avec les vis prévues.  
Sind mehrere Stützleisten erforderlich, richten Sie diese anhand der Verbindungsblaschen (F) miteinander aus und sichern Sie diese dann mit den entsprechenden Schrauben.

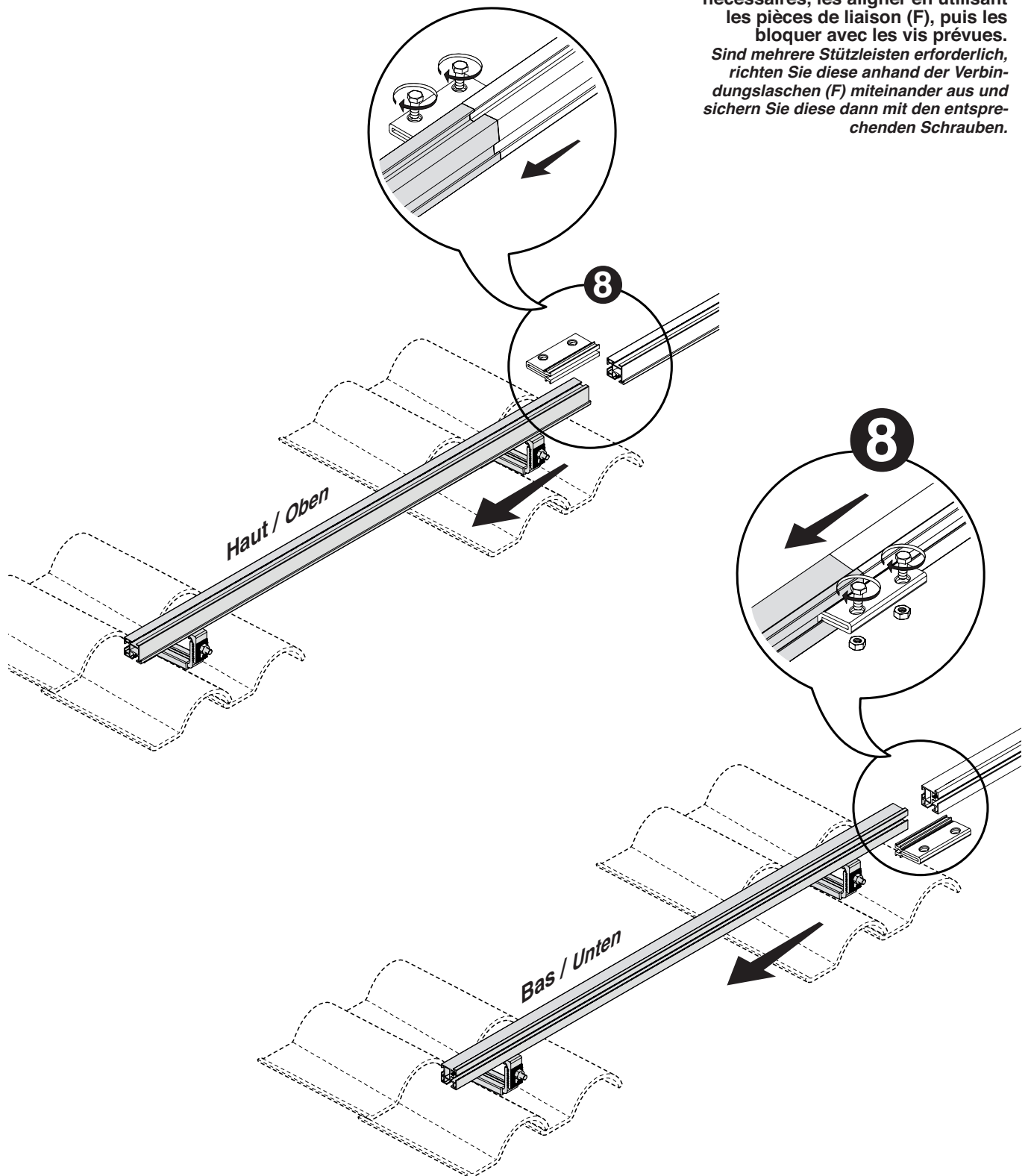

**Kit de blocage des capteurs (H)**  
**Satz Kollektor-Klemmbügel (H)**

**10a** Insérer / Einsetzen

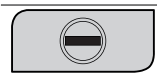

**10b** Tourner de 90  
Um 90° drehen

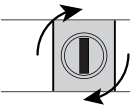

Après avoir serré, vérifier que la fente de la vis est **ORTHO**GNONALE par rapport au rail.  
 Überprüfen Sie nach der Befestigung, ob der Schraubenschlitz **SENKRECHT** zur Position der Stützleiste steht.

**10**

Mettre les vis rectangulaires et fixer le capteur solaire aux rails de support supérieurs à l'aide des crochets.  
 Bringen Sie die rechteckigen Schrauben an und befestigen Sie den Solarkollektor an den oberen Stützeisen

**10**



Faire coïncider les dents du crochet avec celles du châssis du capteur.  
 Fluchten Sie die Zähne des Bügels mit denen des Kollektorrahmens.

**9**

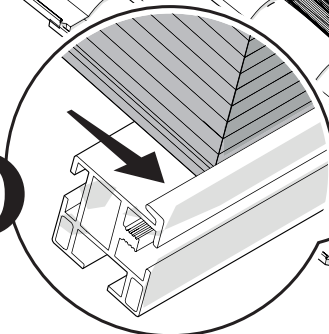

**11a**

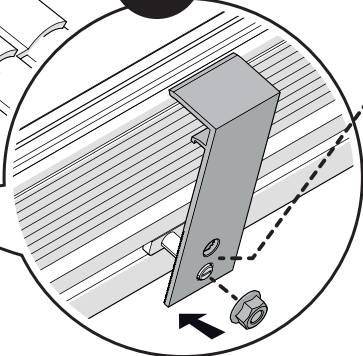

- Pour capteur de 2.0 m<sup>2</sup>  
Für 2.0 m<sup>2</sup> Kollektor
- Pour capteur de 2.5 m<sup>2</sup>  
Für 2.5 m<sup>2</sup> Kollektor

**Pa** Insérer / Einsetzen

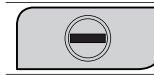

Mettre les vis à tête rectangulaire dans la position Pa sur le rail de support inférieur et préparer le crochet sur la vis.  
 Führen Sie die Schrauben mit Rechteckkopf in Position Pa in die untere Stützleiste ein und richten Sie die Klammer auf der Schraube aus.



Après avoir serré, vérifier que la fente de la vis est **ORTHO**GNONALE par rapport au rail.  
 Überprüfen Sie nach der Befestigung, ob der Schraubenschlitz **SENKRECHT** zur Position der Stützleiste steht.

**Pb** Tourner de 90° / Um 90° drehen

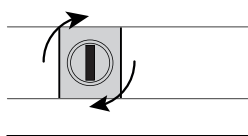

**11b**

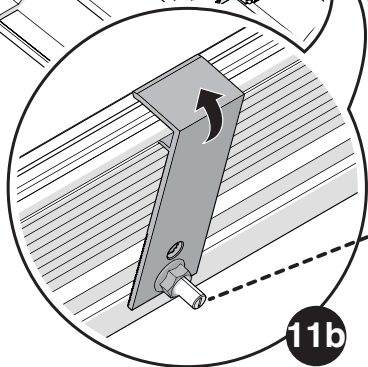

Insérer le crochet sur le profilé du capteur en le faisant légèrement tourner. Tourner la vis à tête rectangulaire dans la position Pb et fixer l'écrou à la vis.  
 Rasten Sie die Klammer mit einer leichten Drehbewegung in das Profil des Kollektors ein. Drehen Sie die Schraube mit Rechteckkopf in Position Pb und ziehen Sie die Mutter auf der Schraube fest.

FRANÇAIS

DEUTSCH



Une fois le capteur fixé, le crochet ne doit pas toucher sa vitre.  
Il est normal qu'il y ait quelques millimètres entre le crochet et la vitre du capteur.  
*Nach der Kollektorbefestigung darf die Klammer nicht auf dem Glas des Kollektors aufliegen. Einige mm Abstand zwischen Klammer und Kollektorglas sind normal.*

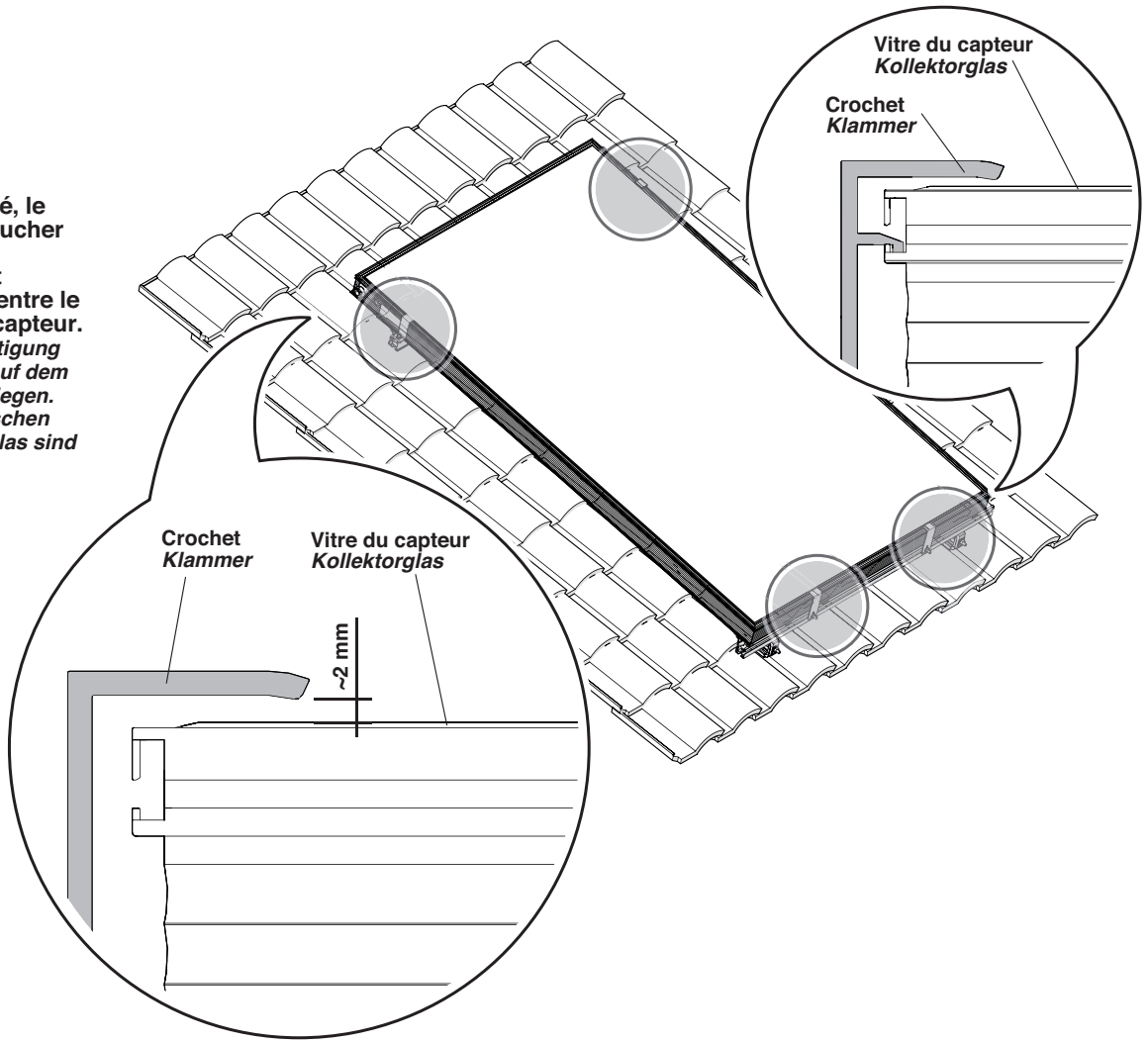

S'il y a plus d'un capteur, répéter les opérations des points 9 - 11 pour chaque capteur.  
*Bei mehreren Kollektoren wiederholen Sie die unter 9 - 11 beschriebenen Schritte für jeden Kollektor.*

**12**

Relier les capteurs entre eux en serrant les raccords hydrauliques avec un couple approprié.  
*Verbinden Sie die Kollektoren durch Festziehen der Wasseranschlüsse mit dem vorgeschriebenen Anzugsmoment.*

UTILISER LE SYSTÈME CLÉ/CONTRE-CLÉ afin de ne pas endommager l'absorbeur.

VERFAHREN SIE NACH DER ARBEITSPRAXIS SCHLÜSSEL-KONTERSCHLÜSSEL, um den Absorber nicht zu beschädigen.

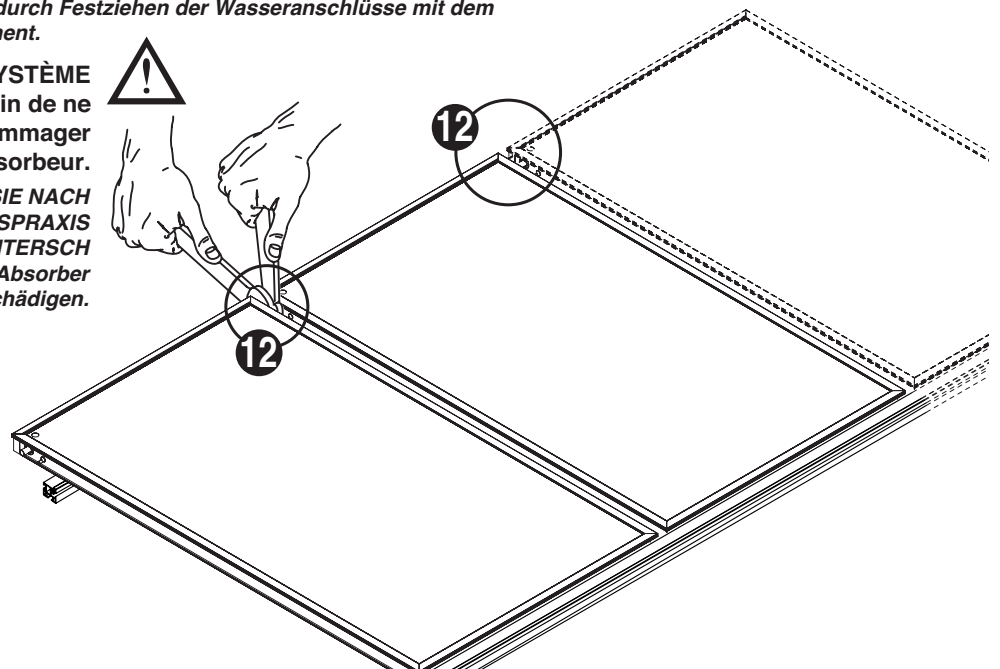
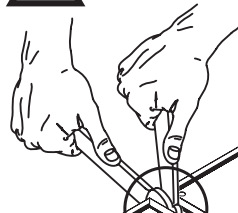

# INSELBARE KIT VOOR BEVESTIGING ONDER DE DAKPAN KIT DE DISPOSITIVOS DE FIJACIÓN REGULABLES BAJO LAS TEJAS

Deze aanwijzingen maken wezenlijk deel uit van de handleiding van de zonnecollector; raadpleeg deze voor de ALGEMENE VOORSCHRIFTEN en FUNDAMENTELE VEILIGHEIDSVORSCHRIFTEN.

Estas instrucciones forman parte integrante del manual del colector solar que rogamos consultar para las ADVERTENCIAS GENERALES y las REGLAS FUNDAMENTALES SOBRE SEGURIDAD.

**⚠** De collectoren moeten uitsluitend geïnstalleerd worden met de bijbehorende montagekit (inclusief de staaf- en bevestigingsaccessoires), die in de Catalogus vermeld staat; in deze handleiding worden de aanwijzingen voor de montage ervan beschreven.

Los colectores se han de instalar exclusivamente con el kit de dispositivos de fijación relativo (que incluye los accesorios barras y para la fijación), indicado en el catálogo, y según las instrucciones de montaje contenidas en este manual.

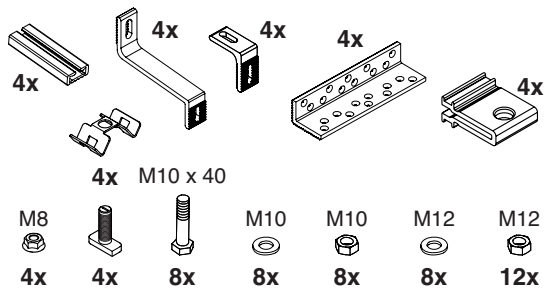

System voor bevestiging aan het dak (D)  
Sistema para la fijación en tejados (D)

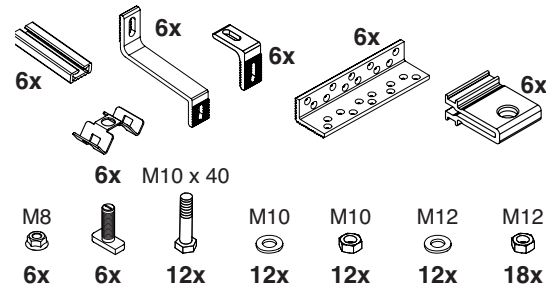

System voor bevestiging aan het dak (E)  
Sistema para la fijación en tejados (E)

Apart worden geleverd:  
Entrega por separado:

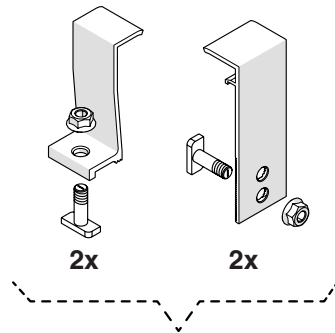

Kit collectorvergrendeling (H)  
Kit de bloqueo colectores (H)

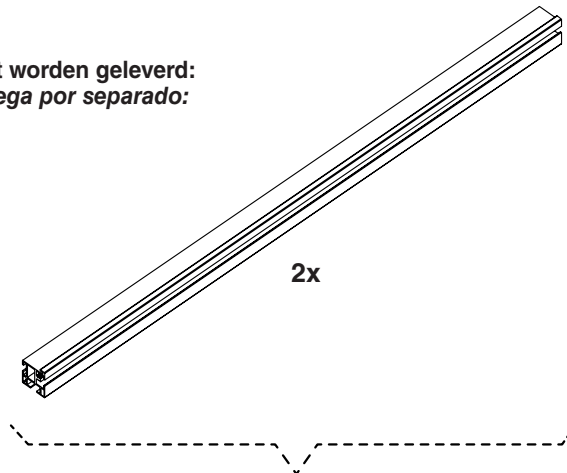

Steunstaven (A-B-C)  
Barras de soporte (A-B-C)

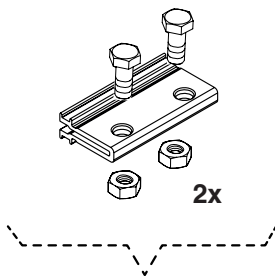

Verbindingsstukken (F)  
(indien nodig)  
Uniones de conexión (F) (si necesarias)

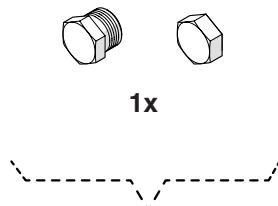

Kit eindstukken (G)  
Kit terminales (G)

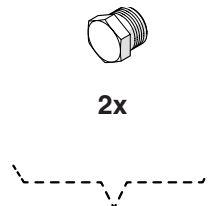

Kit eindstukken (L)  
Kit terminales (L)

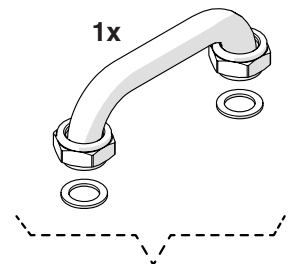

Aansluitstukken (I)  
Empalmes de conexión (I)

NEDERLANDS

ESPAÑOL

## Mogelijke configuraties (verticaal) Configuraciones posibles (vertical)

In de tabellen staan aantal en soort componenten vermeld, die besteld kunnen worden op grond van de gekozen installatieconfiguratie.

Las tablas indican las cantidades y los tipos de componentes que pedir según la configuración elegida para la instalación.

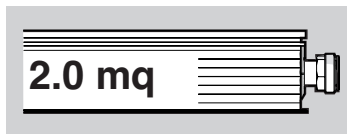

### VERTICALE collector 2,0 m<sup>2</sup> met BAK (4 aansluitingen G 1") Colector de 2.0 m<sup>2</sup> VERTICAL con BASTIDOR (4 tomas G 1")

COMPONENTEN COMPONENTES			Aantal collectoren / Número de colectores					
			1	2	3	4	5	6
Steunstaven Barras de soporte	A	20087442	1x					
	B	20087443		1x		2x	1x	
	C	20087444			1x		1x	2x
Bevestigingssysteem / Sistema de fijación	D	20093051	1x	1x		2x	1x	
	E	20093052			1x		1x	2x
Verbindingsstukken / Uniones de conexión	F	20093048				1x	1x	1x
Kit aansluiting eindstukken / Kit empalme terminales	G	20094627	1x	1x	1x	1x	1x	1x
Kit collectorvergrendeling Kit de bloqueo colectores	H	20093047	1x	2x	3x	4x	5x	6x

Alle aanvullende componenten van de installatie staan vermeld in de cataloguslijst; raadpleeg deze voor nadere info.

Consultar el catálogo que contiene todos los elementos que completan la instalación.

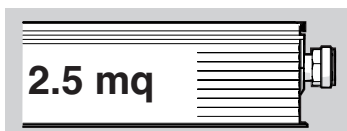

### VERTICALE collector 2,5 m<sup>2</sup> met BAK (2 aansluitingen G 1") Colector de 2.5 m<sup>2</sup> VERTICAL con BASTIDOR (2 tomas G 1")

COMPONENTEN COMPONENTES			Aantal collectoren/ Número de colectores					
			1	2	3	4	5	6
Steunstaven Barras de soporte	A	20087437	1x					
	B	20087438		1x		2x	1x	
	C	20087439			1x		1x	2x
Bevestigingssysteem / Sistema de fijación	D	20093051	1x	1x		2x	1x	
	E	20093052			1x		1x	2x
Verbindingsstukken / Uniones de conexión	F	20093048				1x	1x	1x
Kit collectorvergrendeling / Kit de bloqueo colectores	H	20093046	1x	2x	3x	4x	5x	6x

Alle aanvullende componenten van de installatie staan vermeld in de cataloguslijst; raadpleeg deze voor nadere info.

Consultar el catálogo que contiene todos los elementos que completan la instalación.

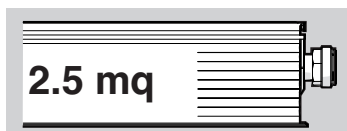

### VERTICALE collector 2.5 m<sup>2</sup> met BAK (4 aansluitingen G 1") Colector de 2.5 m<sup>2</sup> VERTICAL con BASTIDOR (4 tomas G 1")

COMPONENTEN COMPONENTES			Aantal collectoren/ Número de colectores					
			1	2	3	4	5	6
Steunstaven Barras de soporte	A	20087437	1x					
	B	20087438		1x		2x	1x	
	C	20087439			1x		1x	2x
Bevestigingssysteem / Sistema de fijación	D	20093051	1x	1x		2x	1x	
	E	20093052			1x		1x	2x
Verbindingsstukken / Uniones de conexión	F	20093048		1x	1x	1x	1x	1x
Kit aansluiting eindstukken / Kit empalme terminales	G	20094627	1x	1x	1x	1x	1x	1x
Kit collectorvergrendeling / Kit de bloqueo colectores	H	20093046	1x	2x	3x	4x	5x	6x

Alle aanvullende componenten van de installatie staan vermeld in de cataloguslijst; raadpleeg deze voor nadere info.

Consultar el catálogo que contiene todos los elementos que completan la instalación.

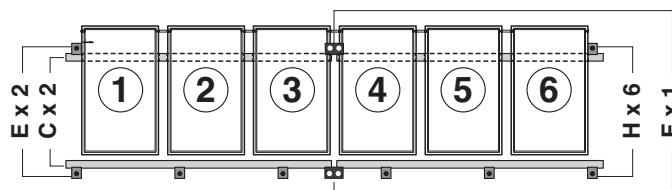
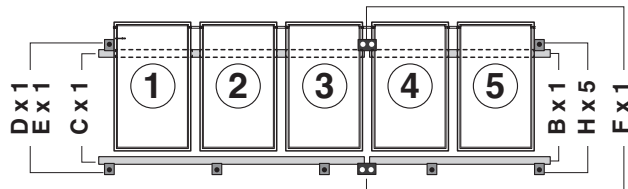
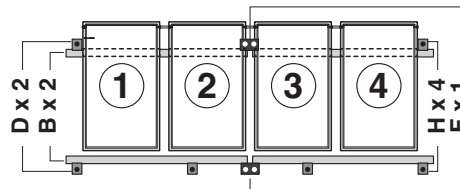
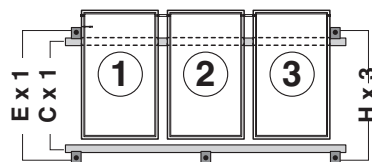
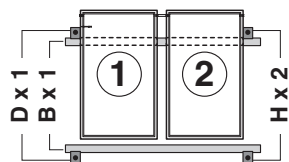
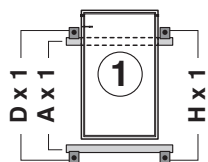

In de tabellen staan aantal en soort componenten vermeld, die besteld kunnen worden op grond van de gekozen installatieconfiguratie.

Las tablas indican las cantidades y los tipos de componentes que pedir según la configuración elegida para la instalación.

## Mogelijke configuraties (horizontaal) Configuraciones posibles (horizontal)

In de tabellen staan aantal en soort componenten vermeld, die besteld kunnen worden op grond van de gekozen installatieconfiguratie.

Las tablas indican las cantidades y los tipos de componentes que pedir según la configuración elegida para la instalación.

2.5 mq

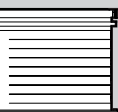

### HORIZONTALE collector 2,5 m<sup>2</sup> met BAK (2 aansluitingen G 1") Colector de 2.5 m<sup>2</sup> HORIZONTAL con BASTIDOR (2 tomas G 1")

COMPONENTEN COMPONENTES			Aantal collectoren / Número de colectores					
			1	2	3	4	5	6
Steunstaven Barras de soporte	A	20093053	1x		1x		1x	
	B	20093054		1x	1x	2x	2x	3x
Bevestigingssysteem / Sistema de fijación	D	20093051	1x		1x		1x	
	E	20093052		1x	1x	2x	2x	3x
Verbindingsstukken / Uniones de conexión	F	20093048			1x	1x	2x	2x
Kit collectorvergrendeling Kit de bloqueo colectores	H	20093046	1x	2x	3x	4x	5x	6x
Aansluitstukken / Empalmes de conexión	I	20094626		1x	2x	3x	4x	5x

Alle aanvullende componenten van de installatie staan vermeld in de cataloguslijst; raadpleeg deze voor nadere info.

Consultar el catálogo que contiene todos los elementos que completan la instalación.

2.5 mq

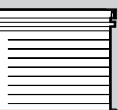

### HORIZONTALE collector 2.5 m<sup>2</sup> met BAK (4 aansluitingen G 1") Colector de 2.5 m<sup>2</sup> HORIZONTAL con BASTIDOR (4 tomas G 1")

COMPONENTEN COMPONENTES			Aantal collectoren / Número de colectores					
			1	2	3	4	5	6
Steunstaven Barras de soporte	A	20093053	1x		1x		1x	
	B	20093054		1x	1x	2x	2x	3x
Bevestigingssysteem / Sistema de fijación	D	20093051	1x	1x		2x	1x	
	E	20093052			1x		1x	2x
Verbindingsstukken / Uniones de conexión	F	20093048		1x	1x	1x	1x	1x
Kit aansluiting eindstukken / Kit empalme terminales	L	20134336	1x	2x	3x	4x	5x	6x
Kit collectorvergrendeling Kit de bloqueo colectores	H	20093046	1x	2x	3x	4x	5x	6x
Aansluitstukken / Empalmes de conexión	I	20094626	1x	2x	3x	4x	5x	6x

Alle aanvullende componenten van de installatie staan vermeld in de cataloguslijst; raadpleeg deze voor nadere info.

Consultar el catálogo que contiene todos los elementos que completan la instalación.

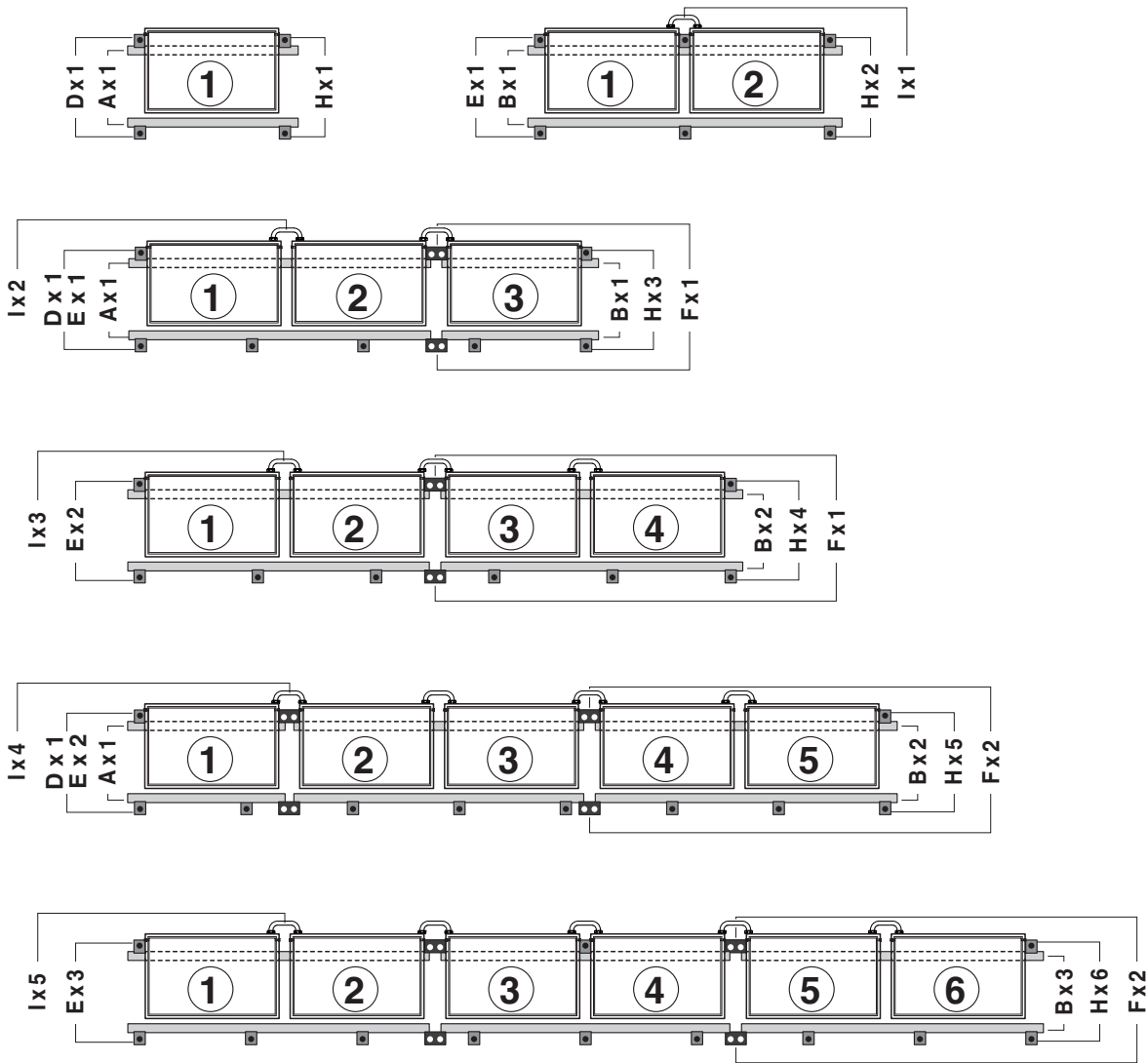

In de tabellen staan aantal en soort componenten vermeld, die besteld kunnen worden op grond van de gekozen installatieconfiguratie.

Las tablas indican las cantidades y los tipos de componentes que pedir según la configuración elegida para la instalación.

## Waarden voor plaatsing van het bevestigingssysteem (D-E) Medidas para situar el sistema de fijación (D-E)

- ⚠ In geval van verbindingstukken tussen de staven, minstens één bevestigingspunt nabij de verbinding voorzien.  
*En barras con una junta de uniones, asegurar al menos un punto de fijación cerca de dicha junta.*
- ⚠ Afmeting H voor bevestiging van de schroeven op de dakpannen kan bij montage naar wens worden afgesteld.  
*La medida H para fijar los tornillos en las tejas se adapta a las exigencias de montaje*

De overige bevestigingspunten gelijkmatig over de volledige lengte verdelen.  
*Distribuir todos los demás puntos de fijación de forma uniforme en toda la longitud.*

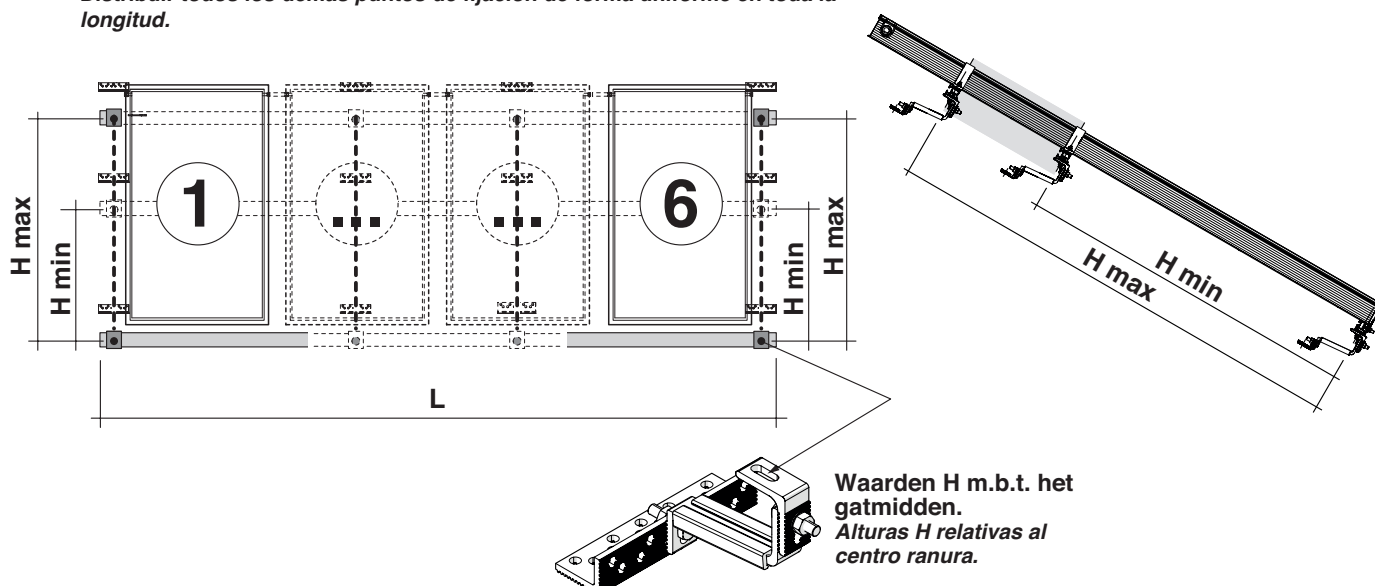

	Waarde Medida  H min - H max (in/en cm)	Aantal collectoren Número de colectores					
		1	2	3	4	5	6
		Lengte / Largo L (in/en cm)					
VERTICALE collector 2,5 m <sup>2</sup> met BAK <i>Colector de 2.5 m<sup>2</sup> VERTICAL con BASTIDOR</i>	160 - 190	120	240	360	480	600	720
VERTICALE collector 2,0 m <sup>2</sup> met BAK <i>Colector de 2.0 m<sup>2</sup> VERTICAL con BASTIDOR</i>	145 - 170	110	220	330	440	550	660
HORIZONTALE collector 2,5 m <sup>2</sup> met BAK <i>Colector de 2.5 m<sup>2</sup> HORIZONTAL con BASTIDOR</i>	90 - 110	210	420	630	840	1050	1260

## Montage / Montaje

### System voor dakbevestiging (D) ) Sistema de fijación para tejados (D)

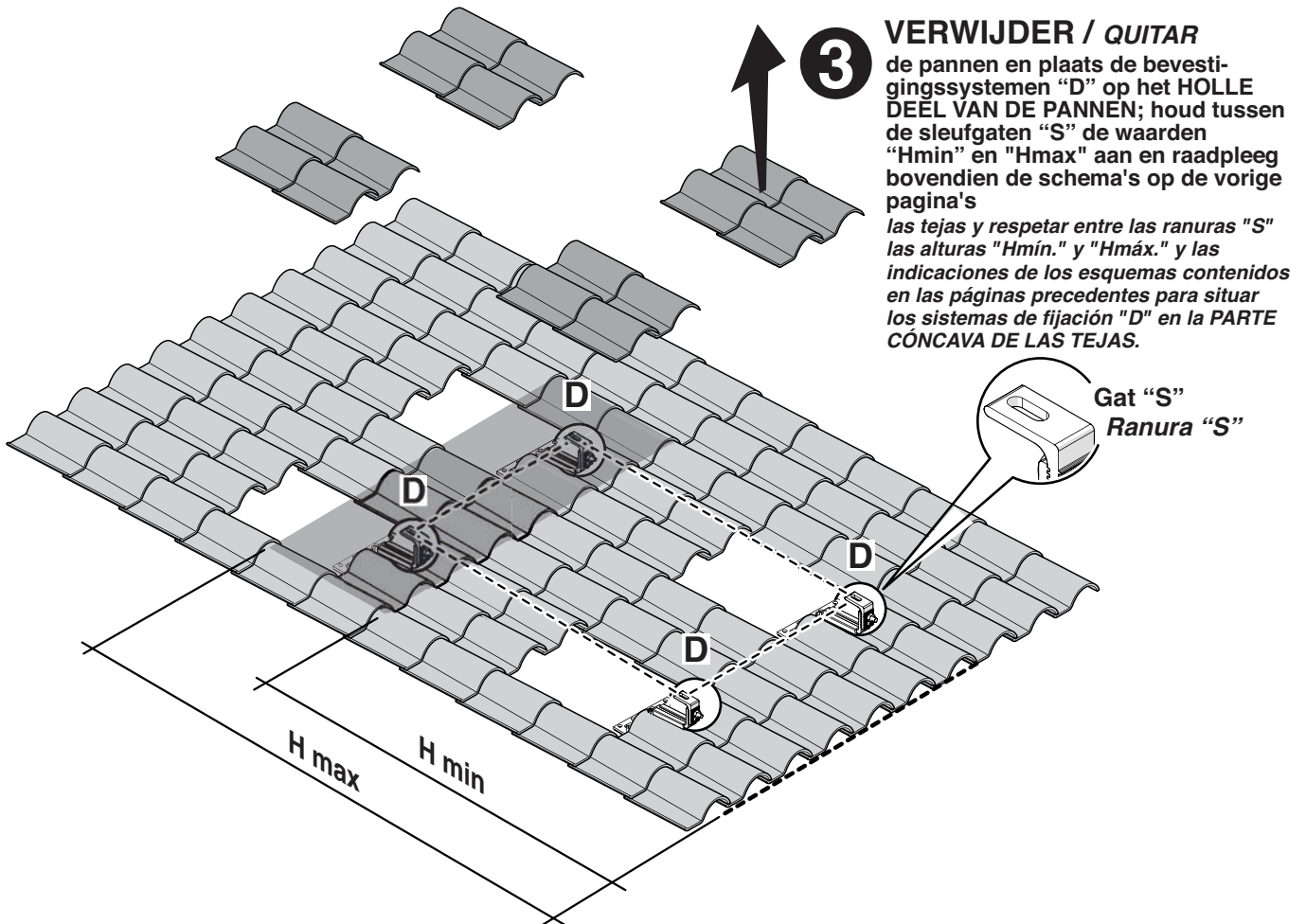
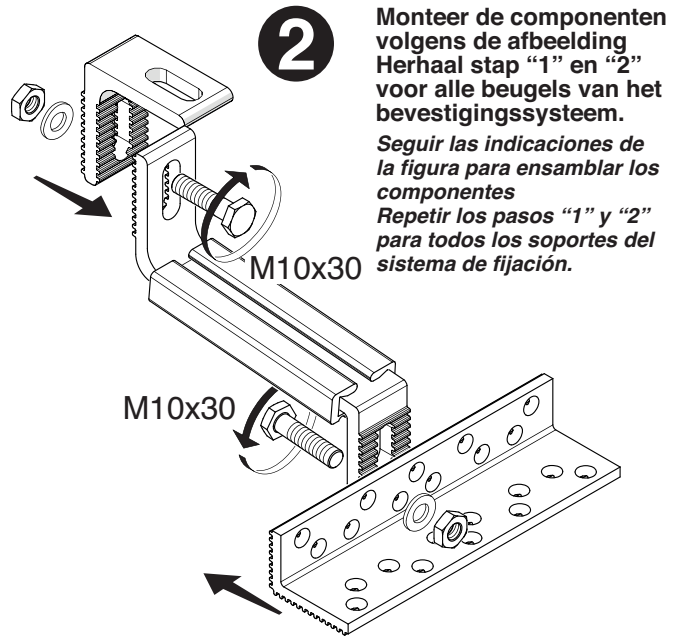
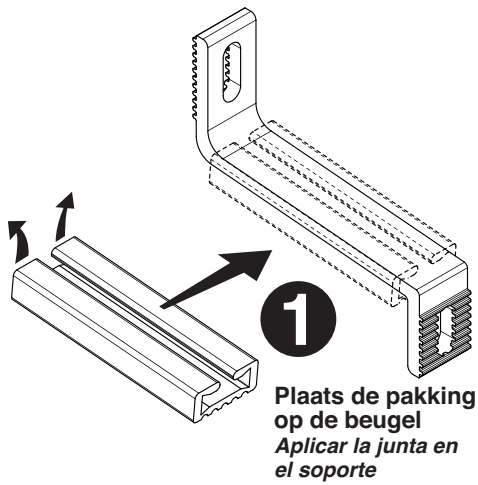

Bereken de plaats van het bevestigingssysteem zodanig dat de L-vormige beugel tegen de pannen aan ligt.

*Calcular la posición del sistema de fijación para que la pletina en L apoye sobre las tejas.*

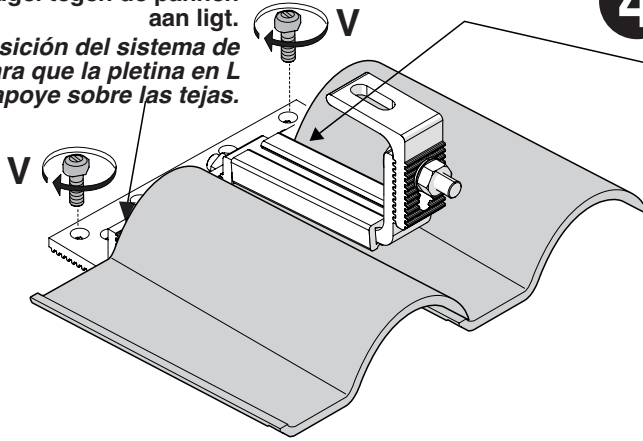

**4**

Zorg ervoor dat het bevestigingssysteem volledig op het dak aansluit. Pas de vorm van de dakpan iets aan, indien nodig. Bevestig de beugels op het dak (elke beugel moet op minstens twee punten vastgezet worden; controleer de bevestiging ervan). De schroeven "V" WORDEN NIET MEEGELEVERD en moeten op grond van de kenmerken van het dak tijdens de installatie aangebracht worden.

*Hacer que el sistema de fijación adhiera al tejado perfectamente. Si es necesario, modelar ligeramente la teja.*

*Fijar los soportes en el tejado (cada soporte ha de estar fijado en dos puntos por lo menos y se ha de controlar su anclaje).*

*Los tornillos "V" NO SE SUMINISTRAN y se han de contemplar en la instalación en base a las características del tejado.*



**MAAK NOOIT GATEN IN DE DAKPANNEN. NO PERFORAR NUNCA LAS TEJAS.**

**5**

**PLAATS / VOLVER A COLOCAR**  
de verwijderde pannen weer TERUG  
*las tejas quitadas antes*

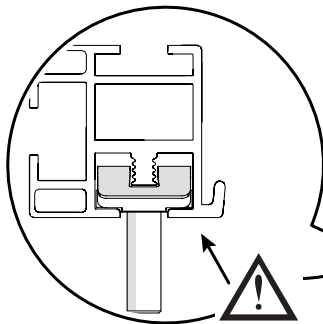
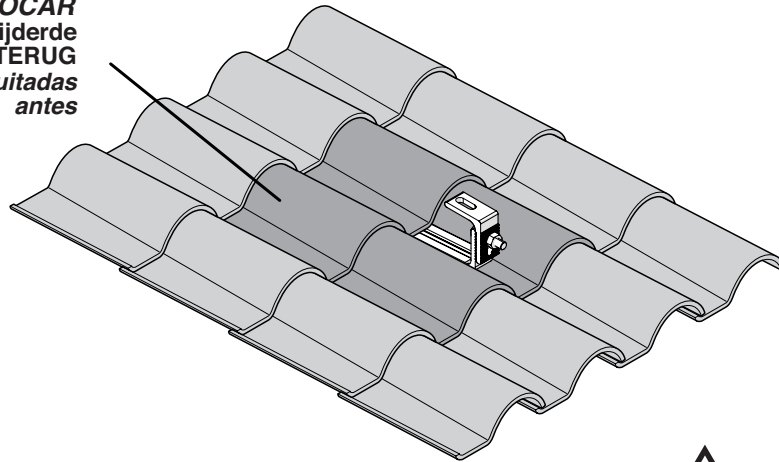

**6**

Breng de hamerschroeven en het bijbehorende blokkeerplaatje aan in de bovenste steunstaaf.

*Introducir y deslizar los tornillos de cabeza de martillo y los relativos elementos de bloqueo rotación en las barras superiores de soporte.*

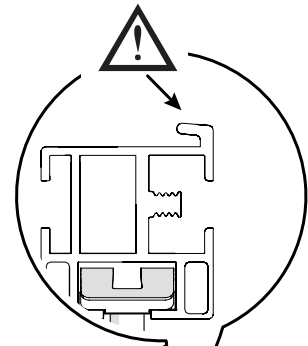

**6**

Breng de hamerschroeven en het bijbehorende blokkeerplaatje aan in de onderste steunstaaf.

*Introducir y deslizar los tornillos de cabeza de martillo y los relativos elementos de bloqueo rotación en las barras inferiores de soporte.*

**7**

Boven / Arriba  
Beneden / Abajo

**7**

**Verbindingsstukken (kit F), indien aanwezig**

(Apart geleverd)

**Uniones de conexión (insertados en el kit F), si presentes**

(Entrega por separado)

Wanneer er meerdere steunstaven nodig zijn, ze onderling uitlijnen met behulp van de verbindingsstukken (F) en ze vastzetten met de bijbehorende schroeven.

*Si hay varias barras de soporte, alinearlas entre sí con las uniones de conexión (F) y bloquearlas con los tornillos correspondientes.*

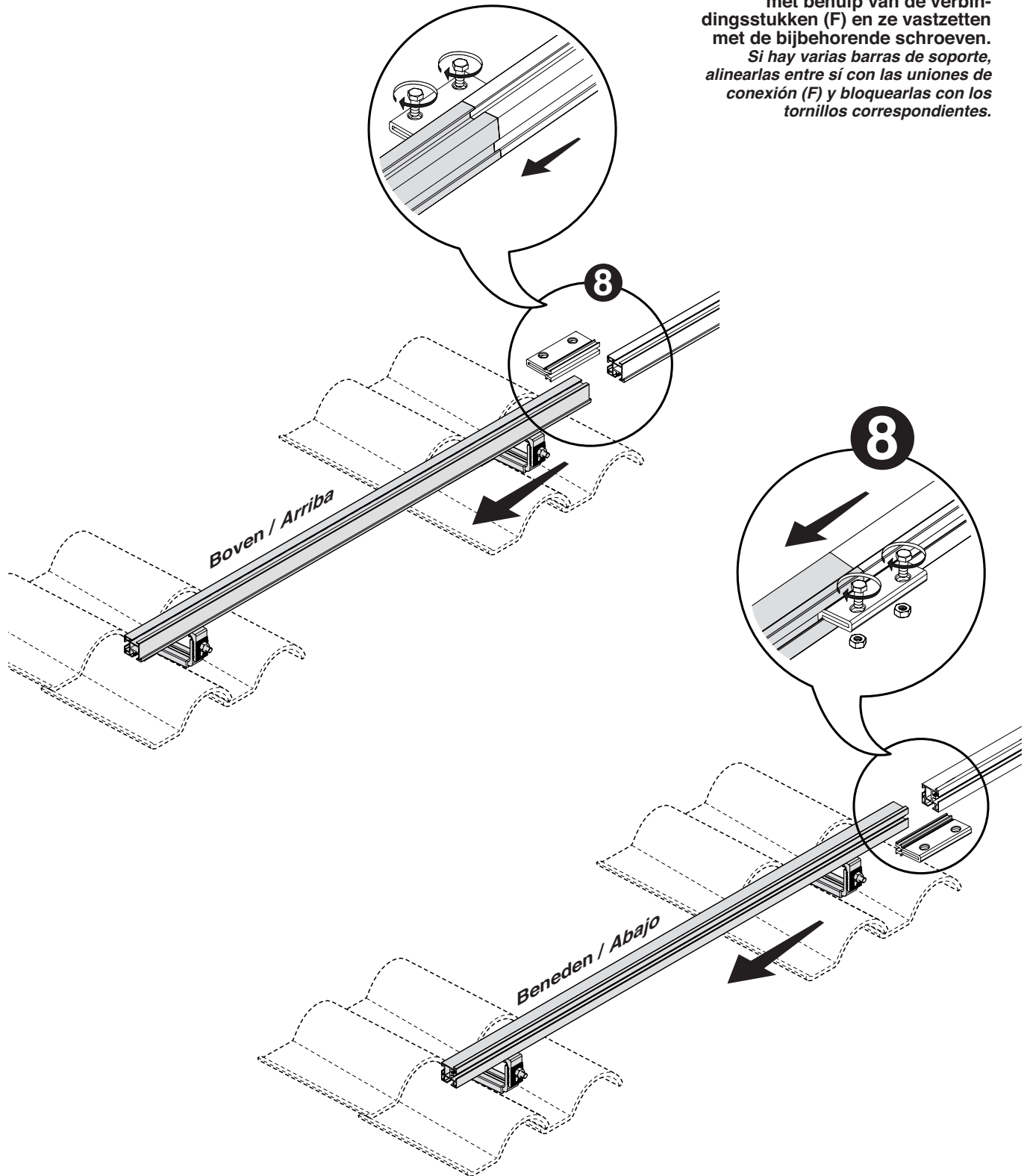

**Kit collectorvergrendeling (H)**  
**Kit de bloqueo colectores (H)**

**10a** Plaats / Insertar

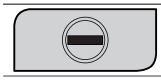

**10b** Draai 90° / Girar a 90°

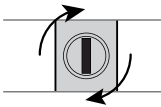

Controleer na het vastzetten of de gleuf van de schroef **LOODRECHT** op de staaf staat.  
 Tras el apriete verificar que la muesca del tornillo se encuentre en una **POSICIÓN ORTOGONAL** respecto de la barra.

Plaats de vierkantschroeven en bevestig de zonnecollector met de beugels aan de bovenste steunstaven.  
 Situar los tornillos rectangulares y fijar el colector solar en las barras superiores de soporte utilizando las grapas.



Zorg ervoor dat de tanden van de staaf in die van de collectorlijst grijpen.  
 Los dientes del soporte han de coincidir con los del marco del colector.

**10**

**10**

**9**

**11a**

**11b**

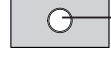
-  Voor collector van 2.0 m<sup>2</sup>  
Para colector de 2.0 m<sup>2</sup>
-  Voor collector van 2.5 m<sup>2</sup>  
Para colector de 2.5 m<sup>2</sup>

**Pa** Plaats / Insertar

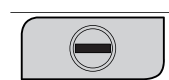

Breng de rechthoekschroeven aan in stand Pa op de onderste steunstaaf en plaats de beugel op de schroef.  
 Situar los tornillos con cabeza rectangular en la posición Pa en la barra de soporte inferior y colocar la grapa en el tornillo.



Controleer na het vastzetten of de gleuf van de schroef **LOODRECHT** op de staaf staat.  
 Tras el apriete verificar que la muesca del tornillo se encuentre en una **POSICIÓN ORTOGONAL** respecto de la barra.

Schuif de beugel op het collectorprofiel en draai hem iets. Draai de rechthoekschroef in stand Pb en zet vast met de moer.  
 Girar ligeramente la grapa para situarla en el perfil del colector. Girar el tornillo con cabeza rectangular para situarlo en la posición Pb y fijar la tuerca en el tornillo.

**Pb** Draai 90° / Girar a 90°

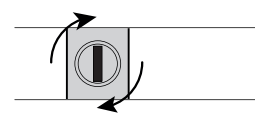



Na bevestiging van de collector mag de beugel niet op het glas van de collector rusten. Normaliter moet er enkele mm ruimte zijn tussen de beugel en het glas van de collector.

*Tras fijar el colector, la grapa no ha de tocar el cristal del colector. Es normal que queden unos mm entre la grapa y el cristal del colector.*

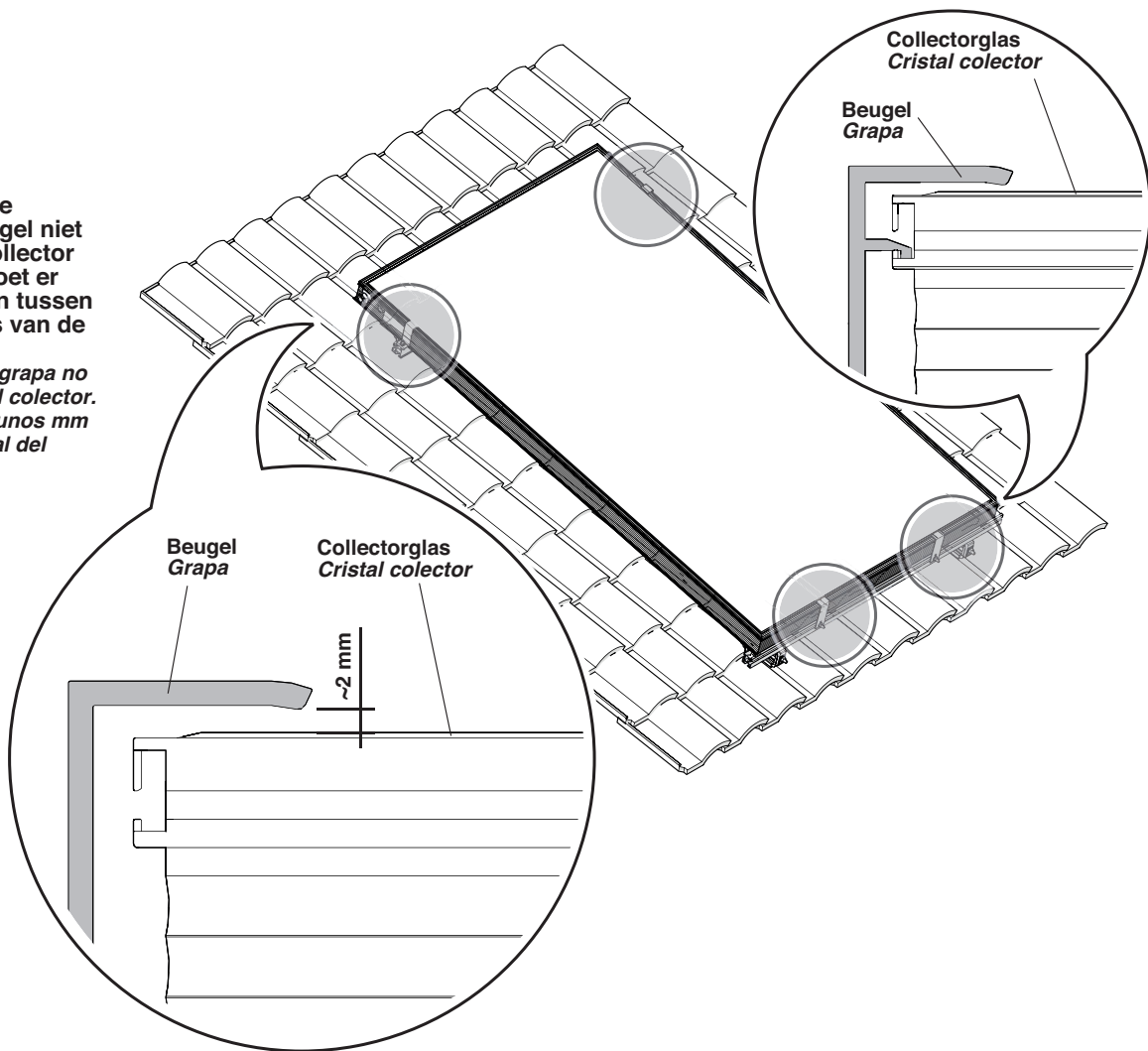

Bij meerdere collectoren stap 9 -11 telkens herhalen.

*Si hay varios colectores, repetir las operaciones descritas en los puntos de 9 - 11 para cada colector.*

**12**

De collectoren met elkaar verbinden en de hydraulische aansluitingen met het juiste koppel aanhalen.

*Apretar los racores hidráulicos con un par adecuado para acoplar los colectores entre sí*

**MAAK GEBRUIK VAN HET SYSTEEM SLEUTEL-TEGENSLEUTEL**

om schade aan de absorberplaat te voorkomen.

**UTILIZAR EL SISTEMA LLAVE-CONTRALLAVE**  
para no estropear el absorbedor.

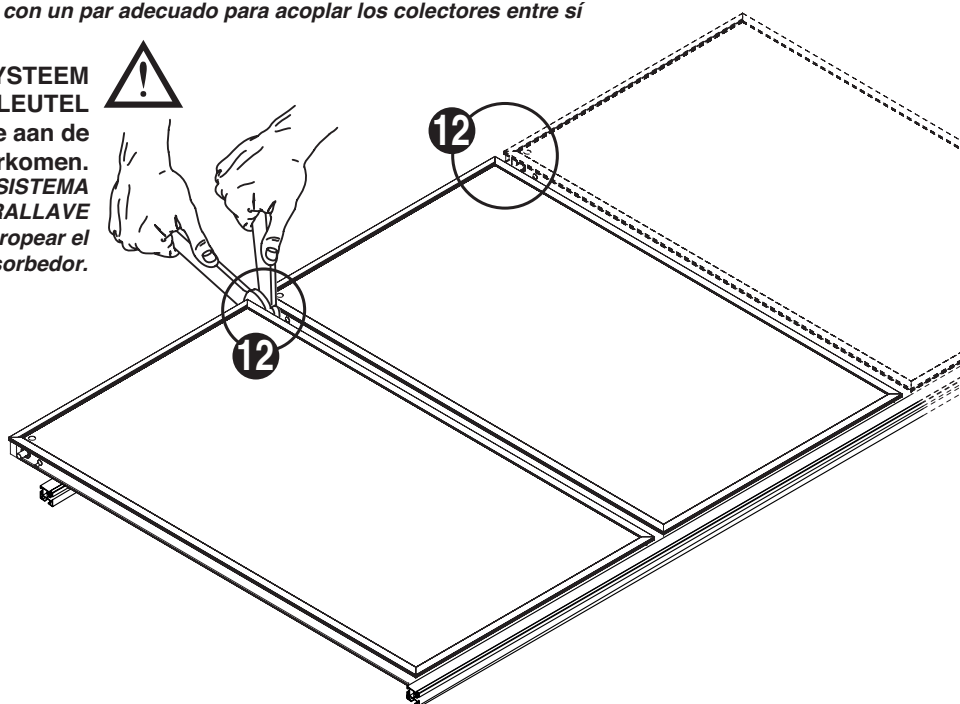



## Configurações possíveis (vertical) Możliwe konfiguracje (pionowo)

Nos quadros estão indicadas as quantidades e tipos de componentes que é necessário encomendar de acordo com a configuração de instalação escolhida.

*W tabelach podano ilości oraz typ części zamawianych w zależności od wybranej konfiguracji montażu.*

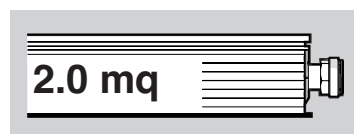

### Coletor de 2,0 m<sup>2</sup> VERTICAL com ARMAÇÃO (4 ligações G 1") Kolektor 2,0 m<sup>2</sup> PIONOWY z OBUDOWĄ (4 przyłącza G 1")

COMPONENTES ELEMENTY			Número de coletores / Liczba kolektorów					
			1	2	3	4	5	6
Barras de suporte Listwy wsporne	A	20087442	1x					
	B	20087443		1x		2x	1x	
	C	20087444			1x		1x	2x
Sistema de fixação / Zestaw montażowy	D	20093051	1x	1x		2x	1x	
	E	20093052			1x		1x	2x
Juntas de união / Płytki połączeniowe	F	20093048				1x	1x	1x
Kit de conexões terminais Zestaw końcówek przyłączeniowych	G	20094627	1x	1x	1x	1x	1x	1x
Kit de bloqueio dos coletores Zestaw do montażu kolektorów	H	20093047	1x	2x	3x	4x	5x	6x

Todos os elementos para completar o sistema estão disponíveis no catálogo, cuja consulta recomendamos.

*Wszystkie elementy uzupełniające do instalacji są dostępne w katalogu, gdzie można znaleźć więcej informacji.*



### Coletor de 2,5 m<sup>2</sup> VERTICAL com ARMAÇÃO (2 ligações G 1") Kolektor 2,5 m<sup>2</sup> PIONOWY z OBUDOWĄ (2 przyłącza G 1")

COMPONENTES ELEMENTY			Número de coletores / Liczba kolektorów					
			1	2	3	4	5	6
Barras de suporte Listwy wsporne	A	20087437	1x					
	B	20087438		1x		2x	1x	
	C	20087439			1x		1x	2x
Sistema de fixação / Zestaw montażowy	D	20093051	1x	1x		2x	1x	
	E	20093052			1x		1x	2x
Juntas de união / Płytki połączeniowe	F	20093048				1x	1x	1x
Kit de bloqueio dos coletores Zestaw do montażu kolektorów	H	20093046	1x	2x	3x	4x	5x	6x

Todos os elementos para completar o sistema estão disponíveis no catálogo, cuja consulta recomendamos.

*Wszystkie elementy uzupełniające do instalacji są dostępne w katalogu, gdzie można znaleźć więcej informacji.*



### Coletor de 2.5 m<sup>2</sup> VERTICAL com ARMAÇÃO (4 ligações G 1") Kolektor 2.5 m<sup>2</sup> PIONOWY z OBUDOWĄ (4 przyłącza G 1")

COMPONENTES ELEMENTY			Número de coletores / Liczba kolektorów					
			1	2	3	4	5	6
Barras de suporte Listwy wsporne	A	20087437	1x					
	B	20087438		1x		2x	1x	
	C	20087439			1x		1x	2x
Sistema de fixação / Zestaw montażowy	D	20093051	1x	1x		2x	1x	
	E	20093052			1x		1x	2x
Juntas de união / Płytki połączeniowe	F	20093048		1x	1x	1x	1x	1x
Kit de conexões terminais Zestaw końcówek przyłączeniowych	G	20094627	1x	1x	1x	1x	1x	1x
Kit de bloqueio dos coletores Zestaw do montażu kolektorów	H	20093046	1x	2x	3x	4x	5x	6x

Todos os elementos para completar o sistema estão disponíveis no catálogo, cuja consulta recomendamos.

*Wszystkie elementy uzupełniające do instalacji są dostępne w katalogu, gdzie można znaleźć więcej informacji.*

PORTUGUÊS

POLISH

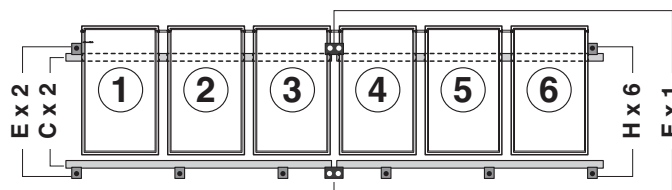
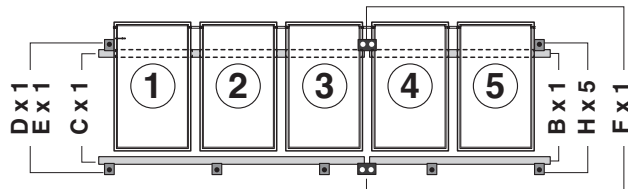
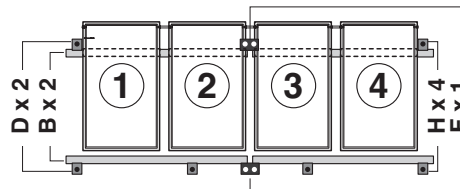
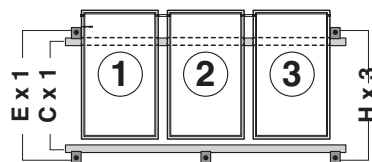
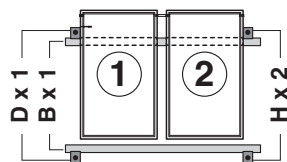
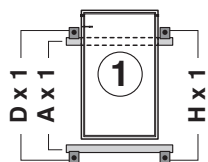

Nos quadros estão indicadas as quantidades e tipos de componentes que é necessário encomendar de acordo com a configuração de instalação escolhida.

*W tabelach podano ilości oraz typ części zamawianych w zależności od wybranej konfiguracji montażu.*

## Configurações possíveis (horizontal) Możliwe konfiguracje (poziomo)

Nos quadros estão indicadas as quantidades e tipos de componentes que é necessário encomendar de acordo com a configuração de instalação escolhida.

*W tabelach podano ilości oraz typ części zamawianych w zależności od wybranej konfiguracji montażu.*

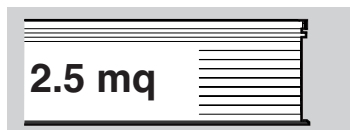

### Coletor de 2,5 m<sup>2</sup> HORIZONTAL com ARMAÇÃO (2 ligações G 1") Kolektor 2,5 m<sup>2</sup> POZIOMY z OBUDOWĄ (2 przyłącza G 1")

COMPONENTES ELEMENTY			Número de coletores / Liczba kolektorów					
			1	2	3	4	5	6
Barras de suporte <i>Listwy wsporne</i>	A	20093053	1x		1x		1x	
	B	20093054		1x	1x	2x	2x	3x
Sistema de fixação / <i>Zestaw montażowy</i>	D	20093051	1x		1x		1x	
	E	20093052		1x	1x	2x	2x	3x
Juntas de união / <i>Płytki połączeniowe</i>	F	20093048			1x	1x	2x	2x
Kit de bloqueio dos coletores <i>Zestaw do montażu kolektorów</i>	H	20093046	1x	2x	3x	4x	5x	6x
Conexões de ligação / <i>Złącza</i>	I	20094626		1x	2x	3x	4x	5x

Todos os elementos para completar o sistema estão disponíveis no catálogo, cuja consulta recomendamos.

*Wszystkie elementy uzupełniające do instalacji są dostępne w katalogu, gdzie można znaleźć więcej informacji.*

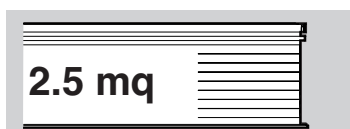

### Coletor de 2.5 m<sup>2</sup> HORIZONTAL com ARMAÇÃO (4 ligações G 1") Kolektor 2.5 m<sup>2</sup> POZIOMY z OBUDOWĄ (4 przyłącza G 1")

COMPONENTES ELEMENTY			Número de coletores / Liczba kolektorów					
			1	2	3	4	5	6
Barras de suporte <i>Listwy wsporne</i>	A	20093053	1x		1x		1x	
	B	20093054		1x	1x	2x	2x	3x
Sistema de fixação / <i>Zestaw montażowy</i>	D	20093051	1x	1x		2x	1x	
	E	20093052			1x		1x	2x
Juntas de união / <i>Płytki połączeniowe</i>	F	20093048		1x	1x	1x	1x	1x
Kit de bloqueio dos coletores <i>Zestaw do montażu kolektorów</i>	L	20134336	1x	2x	3x	4x	5x	6x
Kit de conexões terminais <i>Zestaw końcówek przyłączeniowych</i>	H	20093046	1x	2x	3x	4x	5x	6x
Conexões de ligação / <i>Złącza</i>	I	20094626	1x	2x	3x	4x	5x	6x

Todos os elementos para completar o sistema estão disponíveis no catálogo, cuja consulta recomendamos.

*Wszystkie elementy uzupełniające do instalacji są dostępne w katalogu, gdzie można znaleźć więcej informacji.*

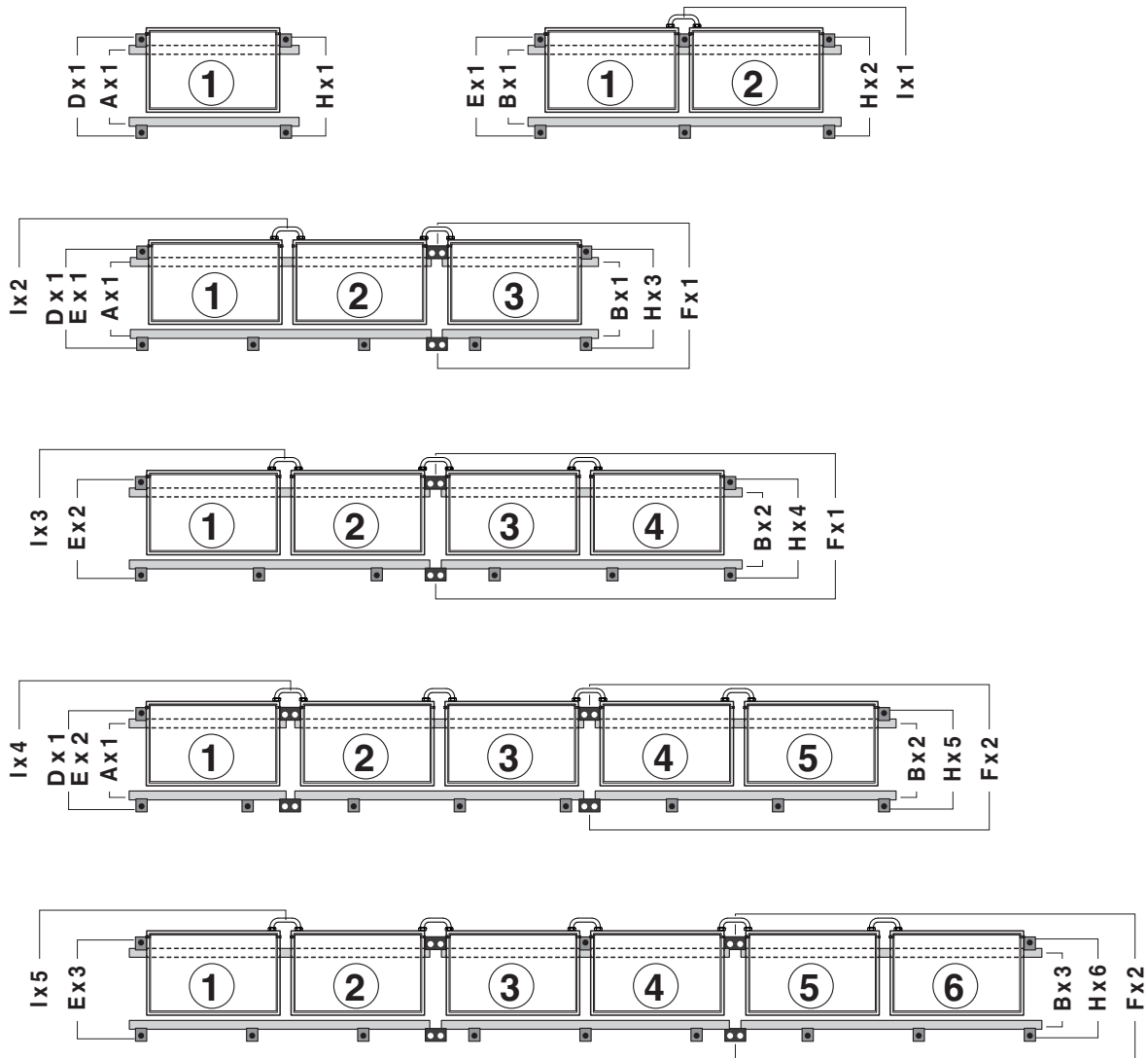

Nos quadros estão indicadas as quantidades e tipos de componentes que é necessário encomendar de acordo com a configuração de instalação escolhida.

*W tabelach podano ilości oraz typ części zamawianych w zależności od wybranej konfiguracji montażu.*

## Medidas para posicionamento do sistema de fixação (D-E) Wymiary do rozmieszczenia zestawu montażowego (D-E)

⚠ Se for necessária uma junta de união entre as barras, garanta pelo menos um ponto de fixação próximo dela.  
*Jeżeli pomiędzy listwami trzeba założyć płytkę połączeniową, w pobliżu płytki powinien być co najmniej jeden punkt mocowania.*

⚠ A medida H para fixação dos parafusos nas telhas pode ser ajustada de acordo com as necessidades de montagem.  
*Wymiar H przy wkręcaniu śrub w dachówki można regulować w zależności od wymogów montażowych.*

Distribua os outros pontos de fixação uniformemente, a todo o comprimento.  
*Pozostałe punkty montażowe rozmieścić równomiernie na całej długości.*

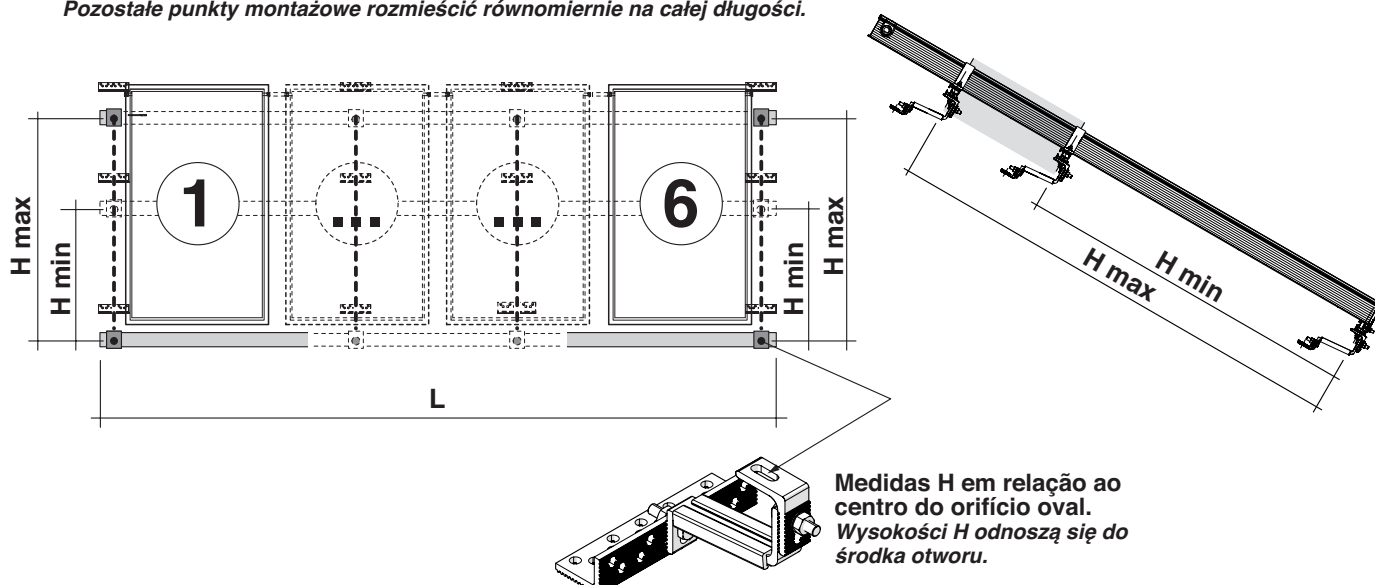

Medidas H em relação ao centro do orifício oval.  
*Wysokości H odnoszą się do środka otworu.*

	Medida Montaż  H min - H max (em/w cm)	Número de coletores Liczba kolektorów					
		1	2	3	4	5	6
		Comprimento / Długość L (em/w cm)					
Coletor de 2,5 m <sup>2</sup> VERTICAL com ARMAÇÃO Kolektor 2,5 m <sup>2</sup> PIONOWY z OBUDOWĄ	160 - 190	120	240	360	480	600	720
Coletor de 2,0 m <sup>2</sup> VERTICAL com ARMAÇÃO Kolektor 2,0 m <sup>2</sup> PIONOWY z OBUDOWĄ	145 - 170	110	220	330	440	550	660
Coletor de 2,5 m <sup>2</sup> HORIZONTAL com ARMAÇÃO Kolektor 2,5 m <sup>2</sup> POZIOMY z OBUDOWĄ	90 - 110	210	420	630	840	1050	1260

PORTUGUÊS

POLISH

## Montagem / Einbau

### Sistema para fixação no telhado (D) Zestaw do montażu na dachu (D)

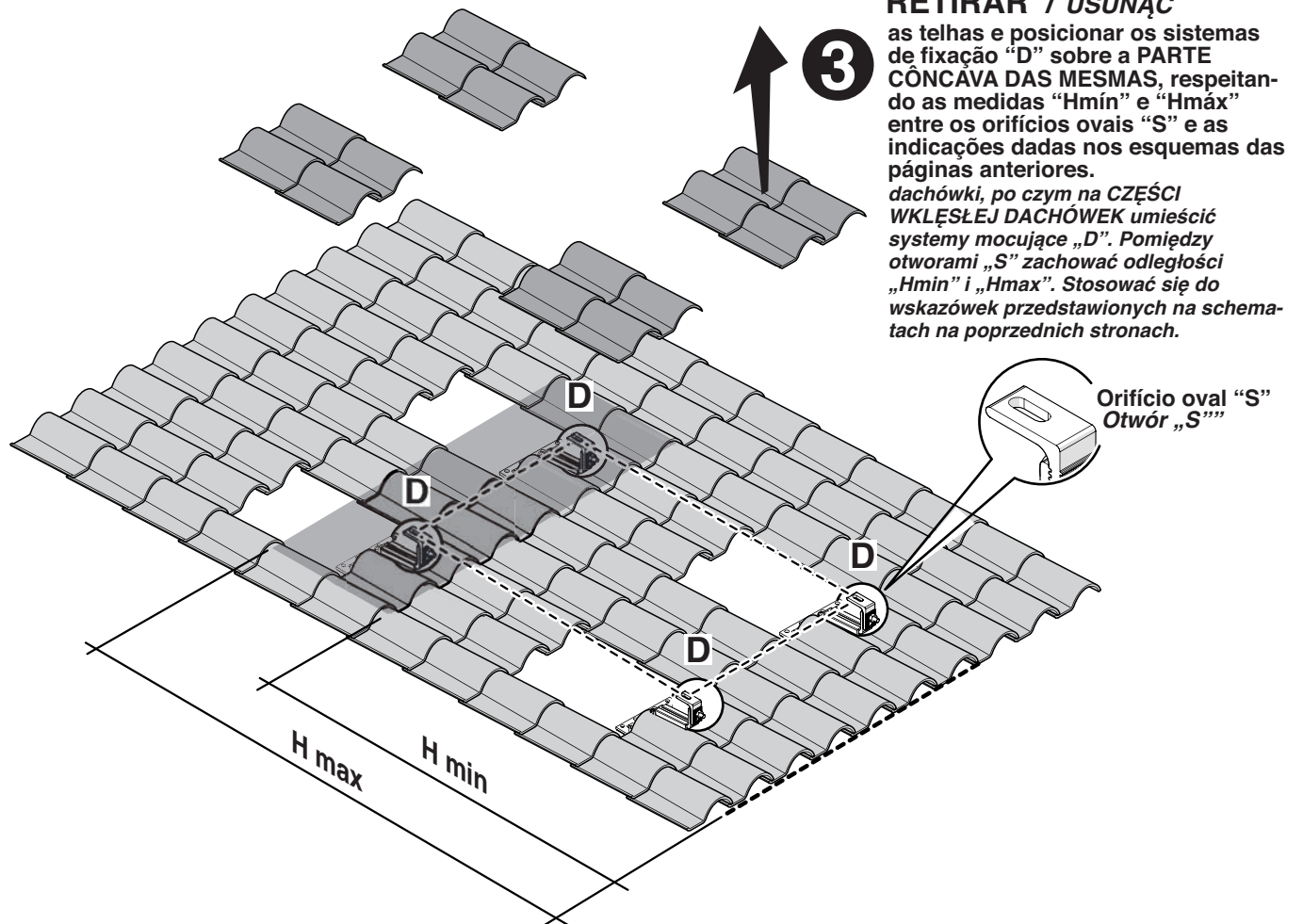
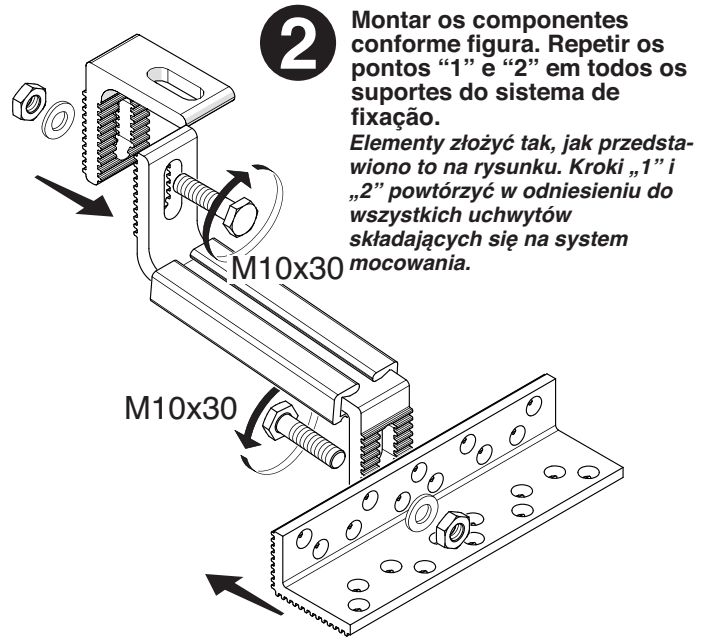
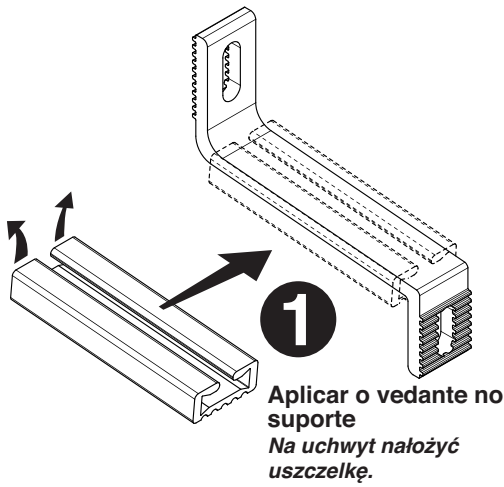

Calcular a posição do sistema de fixação de modo a fazer com que o suporte em L fique apoiado nas telhas

*Pozycję systemu mocującego ustalić tak, by uchwyt w kształcie litery L opierał się o dachówki.*

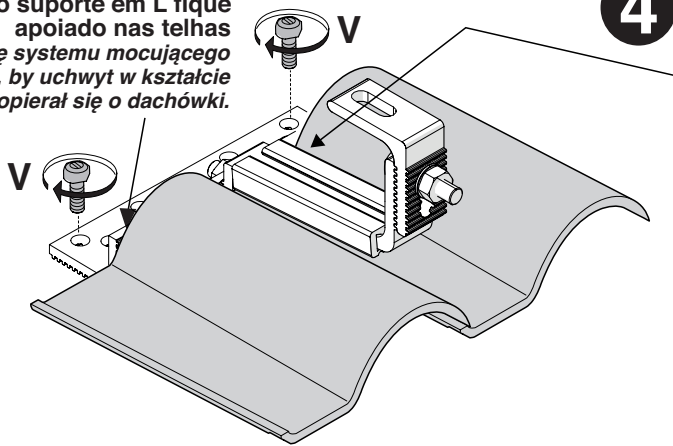

**4** Encostar bem o sistema de fixação ao telhado. Se for necessário, modelar a telha ligeiramente. Fixar os suportes no telhado (cada suporte terá de ser fixado, pelo menos, em dois pontos e verificada a sua fixação mecânica). Os parafusos "V" NÃO SÃO FORNECIDOS DE SÉRIE. Têm de ser adquiridos pelo cliente para a instalação, de acordo com as características do telhado.

*System mocujący powinien dokładnie przylegać do dachu. Jeśli to konieczne, lekko wymodelować dachówkę. Uchwyty przymocować do dachu (każdy uchwyt powinien być przymocowany w co najmniej dwóch punktach. Skontrolować trwałość połączenia). Śruby „V” NIE ZOSTAŁY DOSTARCZONE i należy je nabyć, dostosowując ich typ do cech dachu.*

**! AS TELHAS NÃO DEVEM ABSOLUTAMENTE SER FURADAS. DACHÓWEK ABSOLUTNIE NIE NALEŻY PRZEWIERCAĆ**

**5** REPOR / PONOWNIE UMIEŚCIĆ as telhas removidas anteriormente dachówki uprzednio usunięte.

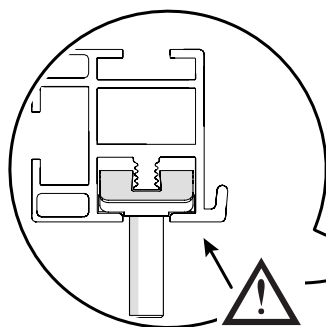
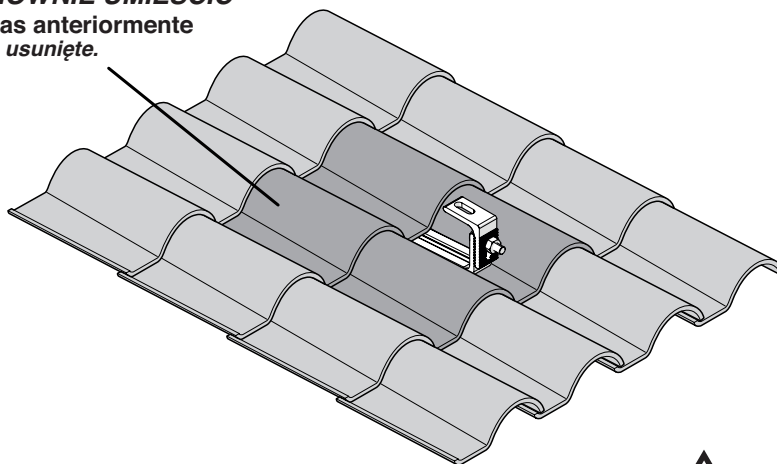

Aplique e faça deslizar os parafusos cabeça de martelo e o respetivo suporte de bloqueio rotação nas barras de suporte superiores.

*W górnych szynach wspornikowych umieścić i przesunąć śruby z łbem młoteczkowym wraz z uchwytem blokującym obroty.*

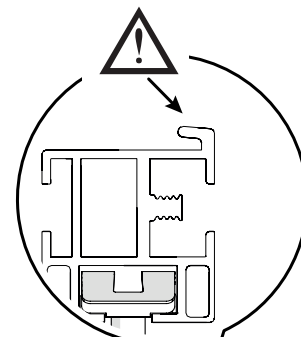

Aplique e faça deslizar os parafusos cabeça de martelo e o respetivo suporte de bloqueio rotação nas barras de suporte inferiores.

*W dolnych szynach wspornikowych umieścić i przesunąć śruby z łbem młoteczkowym wraz z uchwytem blokującym obroty.*

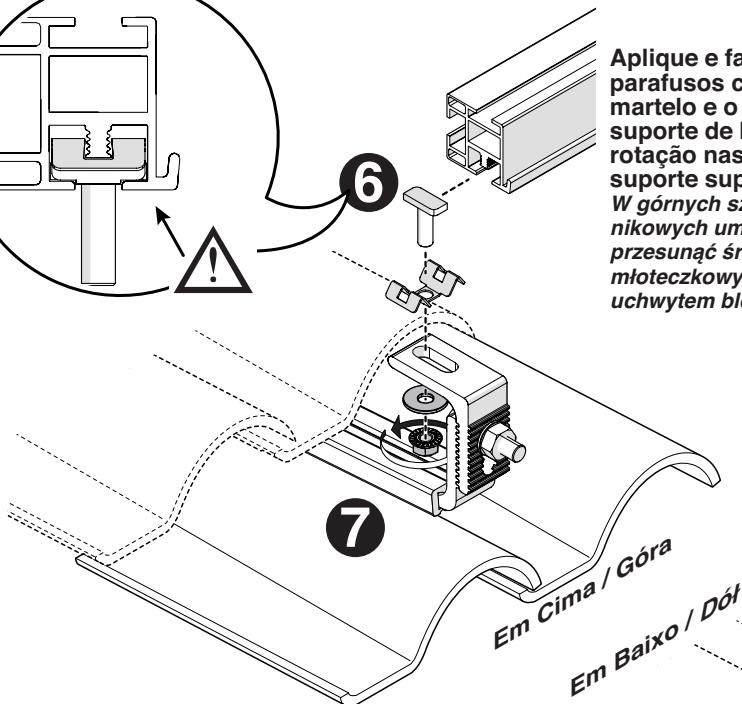

Em Cima / Góra

Em Baixo / Dół

PORTUGUÊS

POLISH

**Juntas de união (incluídas no kit F), se disponíveis  
(Fornecidas separadamente)**

***Plytki połączeniowe (dołączane do zestawu F), jeżeli są  
(Dostarczane oddzielnie)***

No caso de haver várias barras de suporte, alinhe-as entre si, utilizando as juntas de união (F), e fixe-as com os parafusos próprios. Jeżeli używanych jest kilka listew wspornych, wyrównać je płytkami połączeniowymi (F), a następnie przyśrubować.

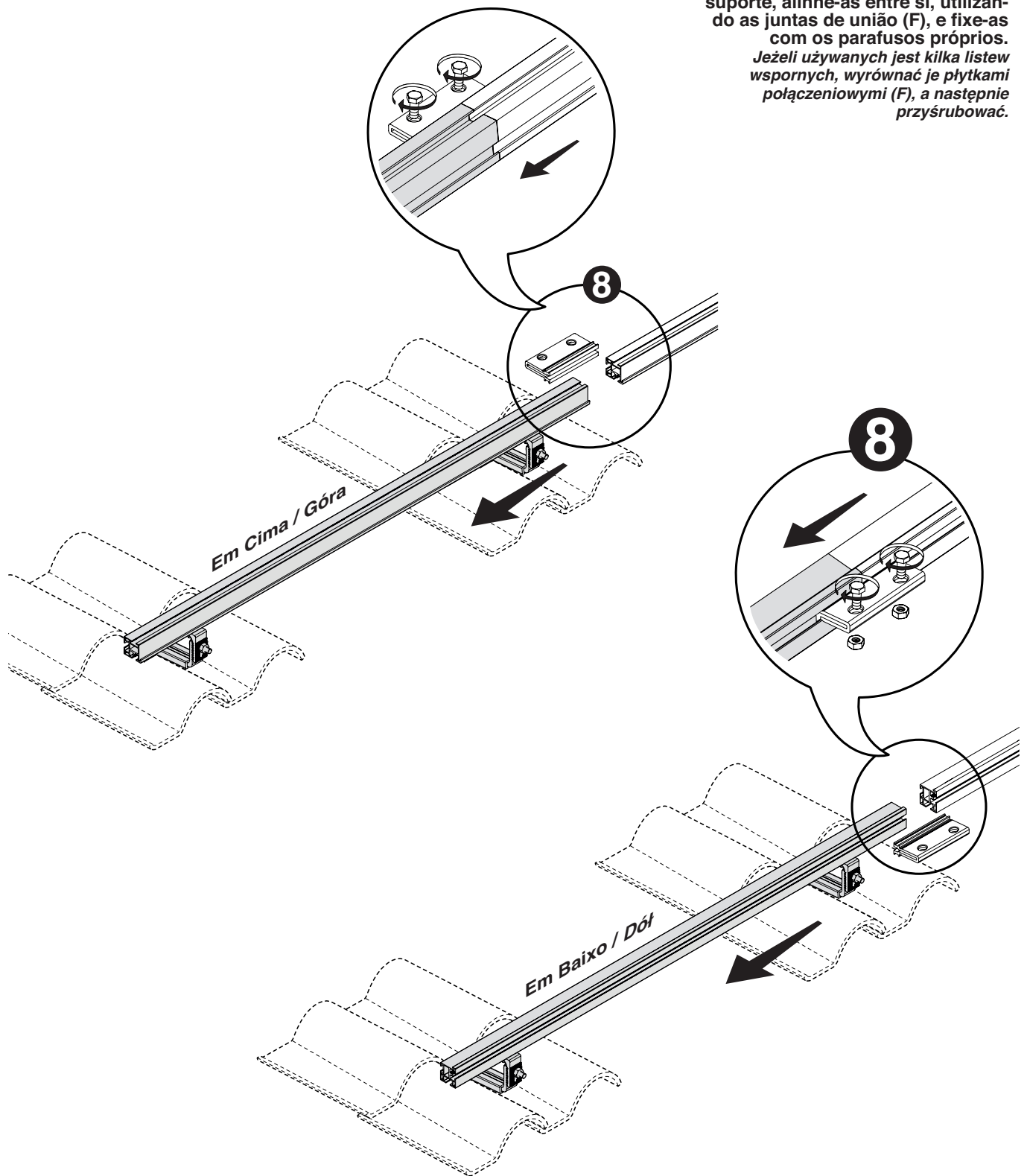

**Kit de bloqueio dos coletores (H)**  
**Zestaw do montażu kolektorów (H)**

**10a** Inserir / Założyć

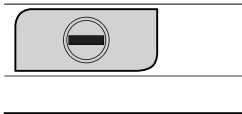

**10b** Rodar 90°  
Obrócić o 90°

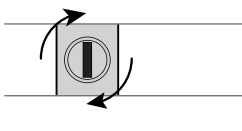

Depois de apertar, verifique se a fenda do parafuso está orientada **PERPENDICULARMENTE** em relação à disposição da barra.

Po montażu sprawdzić, czy nacięcie na śrubie jest **POŁOŻONE PROSTOPADLE** do listwy.

Coloque os parafusos retangulares e fixe o coletor solar nas barras de suporte superiores, utilizando os grampos.

Założyć śruby prostokątne i przymocować kolektor słoneczny do górnych listew wspornych klamrami.

**10**



Encaixe os dentes do suporte nos dentes da armação do coletor. Wyrównać zęby wspornika z zębami ramy kolektora.

**9**

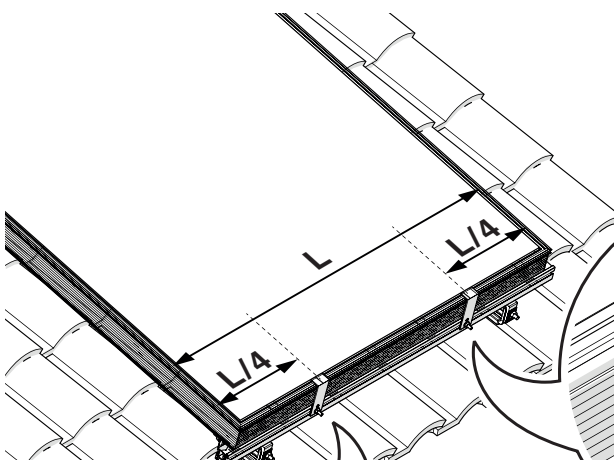

**11a**

- Para coletor de 2.0 m<sup>2</sup>  
Dla kolektora o pow. 2.0 m<sup>2</sup>
- Para coletor de 2.5 m<sup>2</sup>  
Dla kolektora o pow. 2.5 m<sup>2</sup>

**Pa** Inserir / Założyć

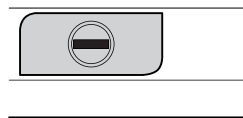

Coloque o parafuso de cabeça retangular na posição Pa da barra de suporte inferior e aplique o grampo sobre o parafuso.

Śruby o prostokątnym łbie należy umieścić w pozycji Pa na dolnym drążku, a następnie na śrubie umieścić spinacz.

**Pb** Rodar 90° / Obrócić o 90°

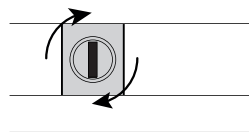

**11b**

Introduza o grampo no perfil do coletor, rodando-o ligeiramente. Rode o parafuso de cabeça retangular para a posição Pb e fixe a porca no parafuso.

Spinacz wprowadzić do profilu kolektora, po czym lekko przekręcić. Śrubę o prostokątnym łbie przekręcić w pozycję Pb, po czym umieścić na niej nakrętkę.



Depois de apertar, verifique se a fenda do parafuso está orientada **PERPENDICULARMENTE** em relação à disposição da barra.

Po montażu sprawdzić, czy nacięcie na śrubie jest **POŁOŻONE PROSTOPADLE** do listwy.



Após fixação do coletor, o grampo não deve ficar apoiado no vidro do coletor. É normal que haja uns milímetros de distância entre o grampo e o vidro do coletor.

Po zamocowaniu kolektora klamra nie może się opierać na szklanej powierzchni kolektora. Kilku milimetrowy odstęp pomiędzy klamrą a szklaną powierzchnią kolektora jest zjawiskiem prawidłowym.

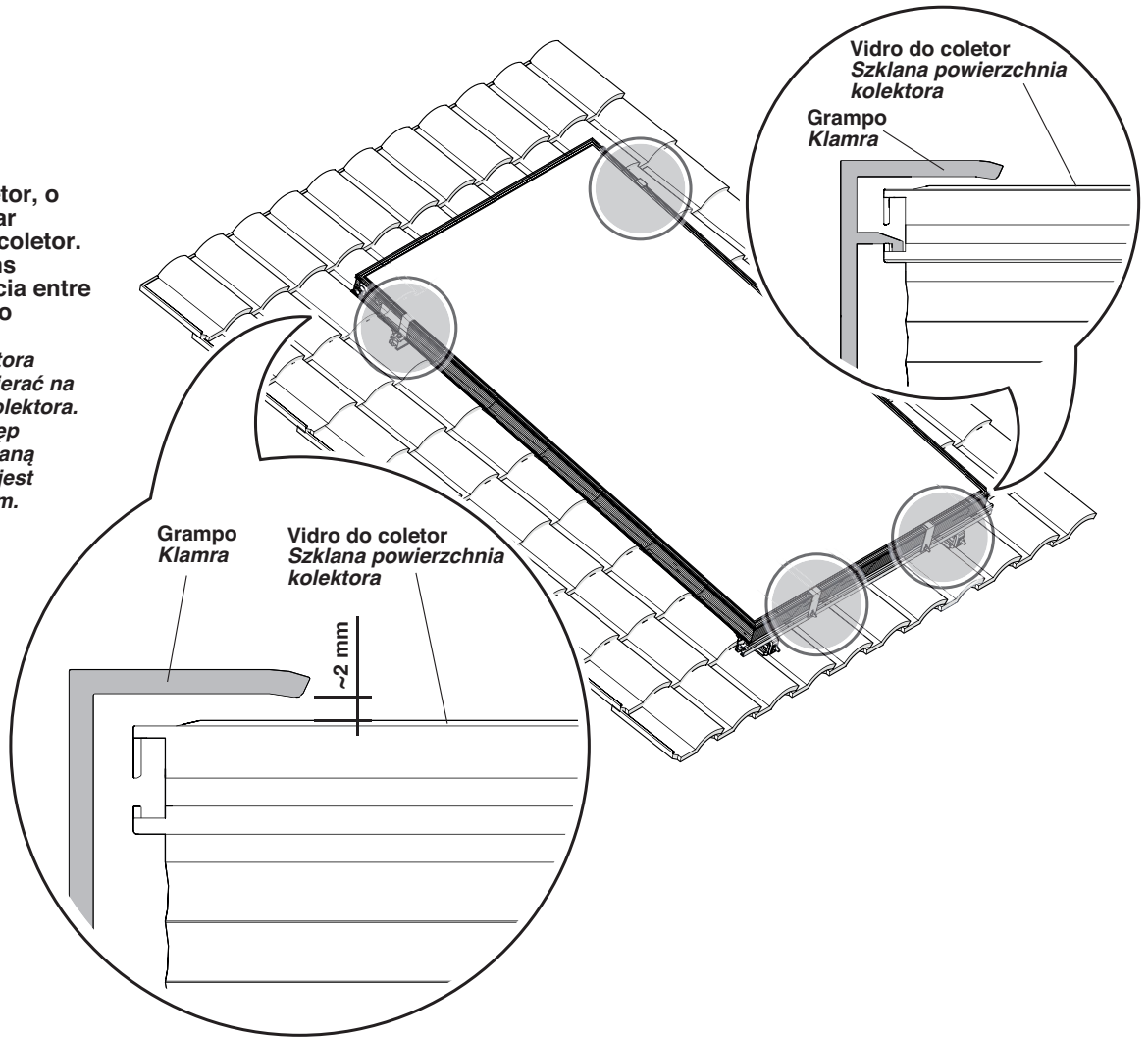

Dispondo de vários coletores, repita em cada um deles as instruções dos pontos 9 - 11. W przypadku montażu kilku kolektorów, dla każdego powtórzyć czynności z punktów 9 - 11.

**12**

Ligue os coletores entre si, apertando as conexões hidráulicas com um binário apropriado. Połączyć kolektory ze sobą dokręcając złącza hydrauliczne z odpowiednią siłą.

**UTILIZE O SISTEMA CHAVE-CONTRACHAVE, para não danificar o absorvedor. Aby nie uszkodzić absorbera, DOKRĘCAĆ Z UŻYCIEM DRUGIEGO NARZĘDZIA PRZYTRZYMUJĄCEGO.**

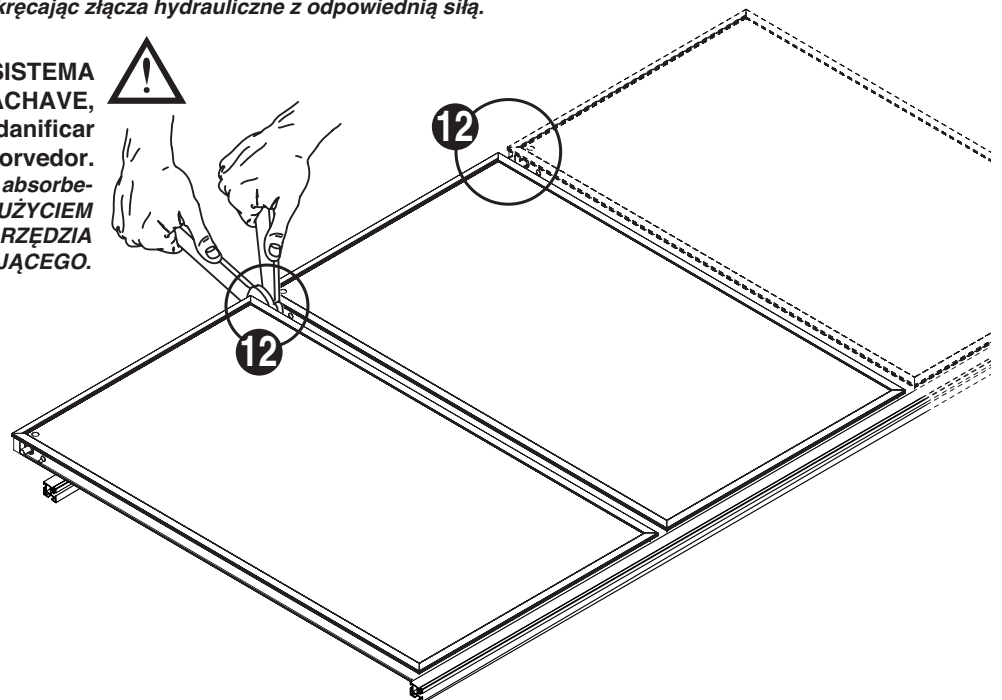
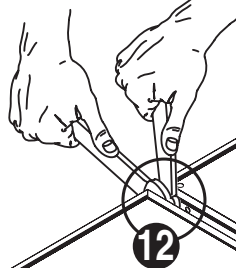

# OPREMA ZA MONTIRANJE ISPOD PODESIVOG CREPA KOMPLET ZA PRILAGODLJIVO MONTAŽO POD STREŠNIKI

Ovo uputstvo je sastvni deo priručnika solarnih kolektora na koji se upućuje radi OPŠTIH UPOZORENJA i radi OSNOVNIH SIGURNOSNIH PROPISA.

To navodilo je sestavni del knjižice za sončne kolektorje, na katero se je treba sklicevati za SPLOŠNA OPOZORILA in TEMELJNA VARNOSTNA PRAVILA.

**!** Kolektori se instaliraju isključivo alatom odgovarajućim za njih (koji uključuje pribor za poluge i pričvršćivanje) navedenih u Katalogu, za koje ovaj priručnik opisuje uputstva za montažu.  
Za namestitev kolektorjev uporabite izključno ustrežni komplet za montažo (ki vključuje letve in pritrdilne elemente), ki je naveden v katalogu in katerega del je tudi ta knjižica, ki opisuje navodila za montažo.

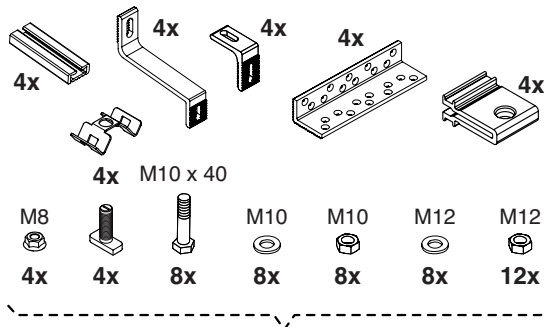

Sistem za fiksiranje na krov (D)  
Sistem za pritrditev na streho (D)

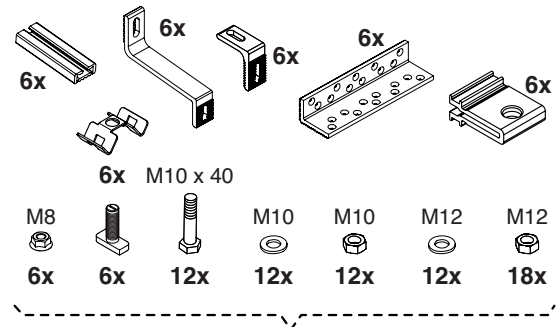

Sistem za fiksiranje na krov (E)  
Sistem za pritrditev na streho (E)

Odvojeni se isporučuju:  
Ločeno na voljo za dobavo:

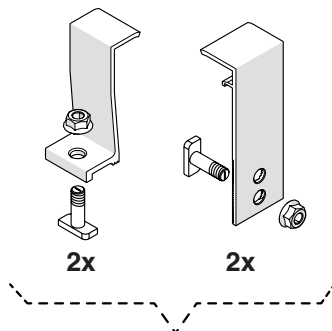

Oprema za blokiranje kolektora (H)  
Komplet za blokiranje kolektorjev (H)

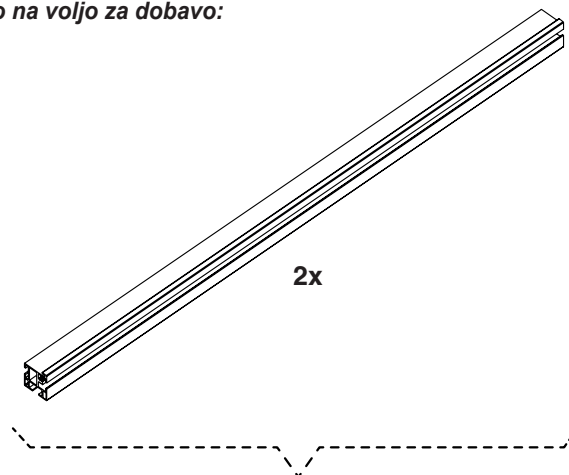

Potporne poluge (A-B-C)  
Nosilne letve (A-B-C)

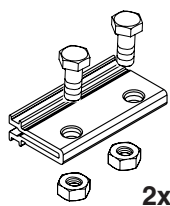

Spojnice (F) (ako su neophodne)  
Prikjučni spoji (F) (če so potrebni)

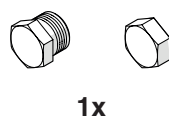

Oprema za završetke (G)  
Komplet končnikov (G)



Oprema za završetke (L)  
Komplet končnikov (L)

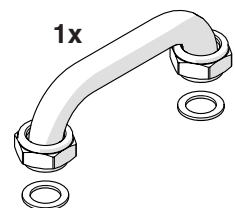

Priključak za povezivanje (I)  
Povezovalni fittingi (I)

## Moguće konfiguracije (vertikalne) Možne konfiguracije (navpična montaža)

U tabelama su izražene količine i vrste delova koje treba poredati prema konfiguraciji izabrane instalacije.  
V tabelah so navedene količine in vrste sestavnih delov, ki jih je treba naročiti glede na izbrano konfiguracijo namestitve.

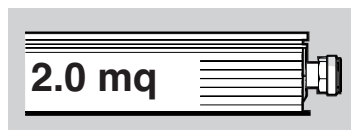

**Kolektor 2.0 m<sup>2</sup> USPRAVNO sa PODLOGOM (4 spoja G 1")**  
**Kolektor 2,0 m<sup>2</sup> za NAVPIČNO MONTAŽO z OKVIRJEM**  
**(4 priključki G 1")**

KOMPONENTE SESTAVNI DELI			Broj kolektora / Število kolektorjev					
			1	2	3	4	5	6
Potporne poluge / Nosilne letve	A	20087442	1x					
	B	20087443		1x		2x	1x	
	C	20087444			1x		1x	2x
Sistem za fiksiranje / Sistem za pritrditev	D	20093051	1x	1x		2x	1x	
	E	20093052			1x		1x	2x
Spojnice / Priključni spoji	F	20093048				1x	1x	1x
Oprema za spojeve završetaka Komplet končnih fittingov	G	20094627	1x	1x	1x	1x	1x	1x
Oprema za blokiranje kolektora Komplet za blokiranje kolektorjev	H	20093047	1x	2x	3x	4x	5x	6x

Svi elementi za sklapanje uređaja su dostupni u katalogu na koji se upućuje radi odgovarajuće konsultacije.  
Vsi elementi za dokončanje namestitve so na voljo v katalogu, v katerem boste našli dodatne informacije.

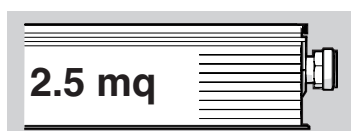

**Kolektor 2.5 m<sup>2</sup> USPRAVNO sa PODLOGOM (2 spoja G 1")**  
**Kolektor 2,5 m<sup>2</sup> za NAVPIČNO MONTAŽO z OKVIRJEM**  
**(2 priključka G 1")**

KOMPONENTE SESTAVNI DELI			Broj kolektora / Število kolektorjev					
			1	2	3	4	5	6
Potporne poluge / Nosilne letve	A	20087437	1x					
	B	20087438		1x		2x	1x	
	C	20087439			1x		1x	2x
Sistem za fiksiranje / Sistem za pritrditev	D	20093051	1x	1x		2x	1x	
	E	20093052			1x		1x	2x
Spojnice / Priključni spoji	F	20093048				1x	1x	1x
Oprema za blokiranje kolektora Komplet za blokiranje kolektorjev	H	20093046	1x	2x	3x	4x	5x	6x

Svi elementi za sklapanje uređaja su dostupni u katalogu na koji se upućuje radi odgovarajuće konsultacije.  
Vsi elementi za dokončanje namestitve so na voljo v katalogu, v katerem boste našli dodatne informacije.



**Kolektor 2.5 m<sup>2</sup> USPRAVNO sa PODLOGOM (4 spoja G 1")**  
**Kolektor 2,5 m<sup>2</sup> za NAVPIČNO MONTAŽO z OKVIRJEM**  
**(4 priključki G 1")**

KOMPONENTE SESTAVNI DELI			Broj kolektora / Število kolektorjev					
			1	2	3	4	5	6
Potporne poluge / Nosilne letve	A	20087437	1x					
	B	20087438		1x		2x	1x	
	C	20087439			1x		1x	2x
Sistem za fiksiranje / Sistem za pritrditev	D	20093051	1x	1x		2x	1x	
	E	20093052			1x		1x	2x
Spojnice / Priključni spoji	F	20093048		1x	1x	1x	1x	1x
Oprema za spojeve završetaka Komplet končnih fittingov	G	20094627	1x	1x	1x	1x	1x	1x
Oprema za blokiranje kolektora Komplet za blokiranje kolektorjev	H	20093046	1x	2x	3x	4x	5x	6x

Svi elementi za sklapanje uređaja su dostupni u katalogu na koji se upućuje radi odgovarajuće konsultacije.  
Vsi elementi za dokončanje namestitve so na voljo v katalogu, v katerem boste našli dodatne informacije.

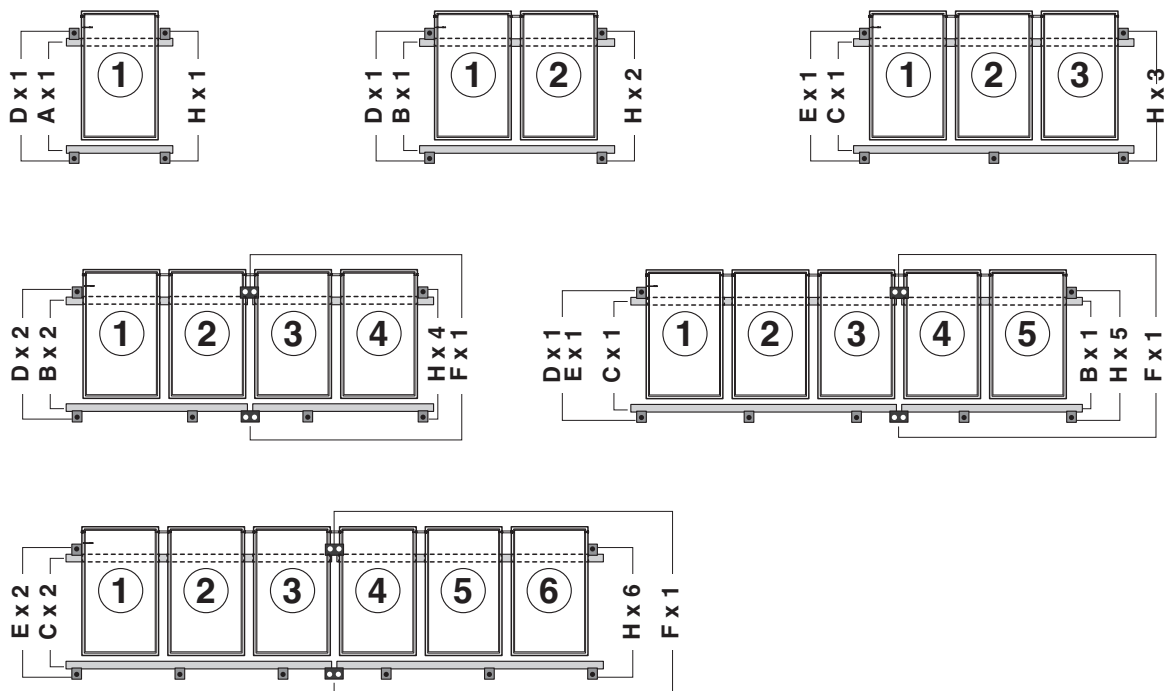

U tabelama su izražene količine i vrste delova koje treba poređati prema konfiguraciji izabrane instalacije.  
 V tabelah so navedene količine in vrste sestavnih delov, ki jih je treba naročiti glede na izbrano konfiguracijo namestitve.

## Moguće konfiguracije (vodoravno) Možne konfiguracije (navpična montaža)

U tabelama su izražene količine i vrste delova koje treba poredati prema konfiguraciji izabrane instalacije.  
V tabelah so navedene količine in vrste sestavnih delov, ki jih je treba naročiti glede na izbrano konfiguracijo namestitve.

**2.5 m<sup>q</sup>**



**Kolektor 2.5 m<sup>q</sup> VODORAVNO sa PODLOGOM (2 spoja G 1")**  
**Kolektor 2,0 m<sup>2</sup> za NAVPIČNO MONTAŽO z OKVIRJEM**  
**(4 priključki G 1")**

KOMPONENTE SESTAVNI DELI			Broj kolektora / Število kolektorjev					
			1	2	3	4	5	6
Potporne poluge / Nosilne letve	A	20093053	1x		1x		1x	
	B	20093054		1x	1x	2x	2x	3x
Sistem za fiksiranje / Sistem za pritrditev	D	20093051	1x		1x		1x	
	E	20093052		1x	1x	2x	2x	3x
Spojnice / Priključni spoji	F	20093048			1x	1x	2x	2x
Oprema za blokiranje kolektora Komplet za blokiranje kolektorjev	H	20093046	1x	2x	3x	4x	5x	6x
Priključci za povezivanje / Povezovalni fittingi	I	20094626		1x	2x	3x	4x	5x

Svi elementi za sklapanje uređaja su dostupni u katalogu na koji se upućuje radi odgovarajuće konsultacije.  
Vsi elementi za dokončanje namestitve so na voljo v katalogu, v katerem boste našli dodatne informacije.

**2.5 m<sup>q</sup>**

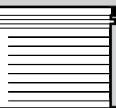

**Kolektor 2.5 m<sup>q</sup> USPRAVNO sa PODLOGOM (4 spoja G 1")**  
**Kolektor 2,5 m<sup>2</sup> za NAVPIČNO MONTAŽO z OKVIRJEM**  
**(4 priključki G 1")**

KOMPONENTE SESTAVNI DELI			Broj kolektora / Število kolektorjev					
			1	2	3	4	5	6
Potporne poluge / Nosilne letve	A	20093053	1x		1x		1x	
	B	20093054		1x	1x	2x	2x	3x
Sistem za fiksiranje / Sistem za pritrditev	D	20093051	1x	1x		2x	1x	
	E	20093052			1x		1x	2x
Spojnice / Priključni spoji	F	20093048		1x	1x	1x	1x	1x
Oprema za spojeve završetaka Komplet končnih fittingov	L	20134336	1x	2x	3x	4x	5x	6x
Oprema za blokiranje kolektora Komplet za blokiranje kolektorjev	H	20093046	1x	2x	3x	4x	5x	6x
Priključci za povezivanje / Povezovalni fittingi	I	20094626	1x	2x	3x	4x	5x	6x

Svi elementi za sklapanje uređaja su dostupni u katalogu na koji se upućuje radi odgovarajuće konsultacije.  
Vsi elementi za dokončanje namestitve so na voljo v katalogu, v katerem boste našli dodatne informacije.

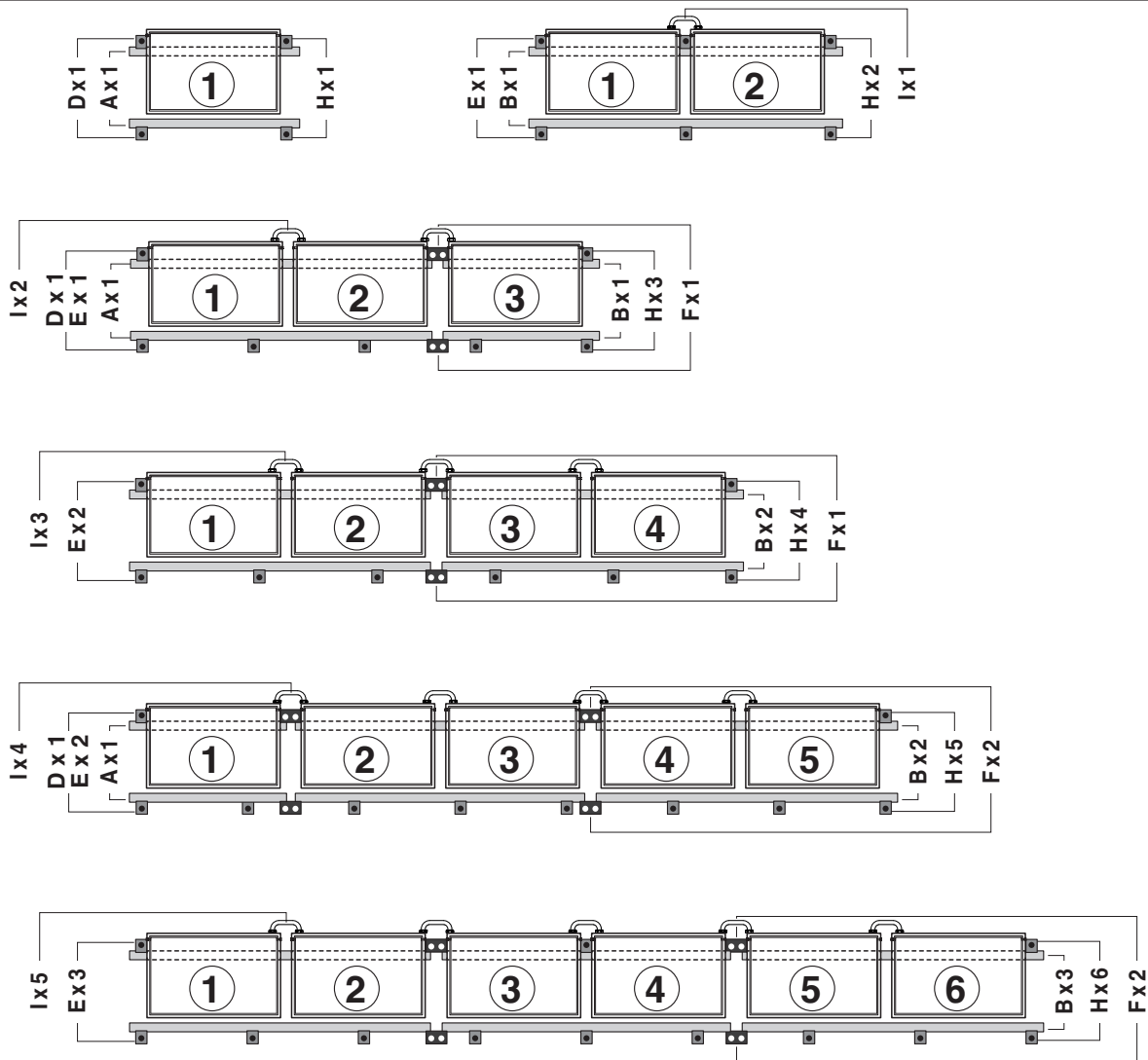

**U tabelama su izražene količine i vrste delova koje treba poredati prema konfiguraciji izabrane instalacije.**  
**V tabelah so navedene količine in vrste sestavnih delov, ki jih je treba naročiti glede na izbrano konfiguracijo namestitve.**

## Kvota za pozicioniranje sistema za fiksiranje (D-E) Mere za postavitev sistema za pritrditev (D-E)

⚠ Tamo gde postoje spojevi između poluga, obezbediti najmanje jedno mesto za fiksiranje u blizini samog spoja. Če je med letvami prisoten priključni spoj, zagotovite vsaj eno pritrdilno točko v bližini samega spoja.

⚠ Dimenzija H za fiksiranje šrafova na crep, može biti podešena prema potrebama montaže. Mero H za pritrditev vijakov na strešnike lahko prilagodite glede na zahteve montaže.

Rasporediti jednako ostale tačke pričvršćivanja po celoj dužini.  
Enakomerno porazdelite druge pritrdilne točke vzdolž celotne dolžine.

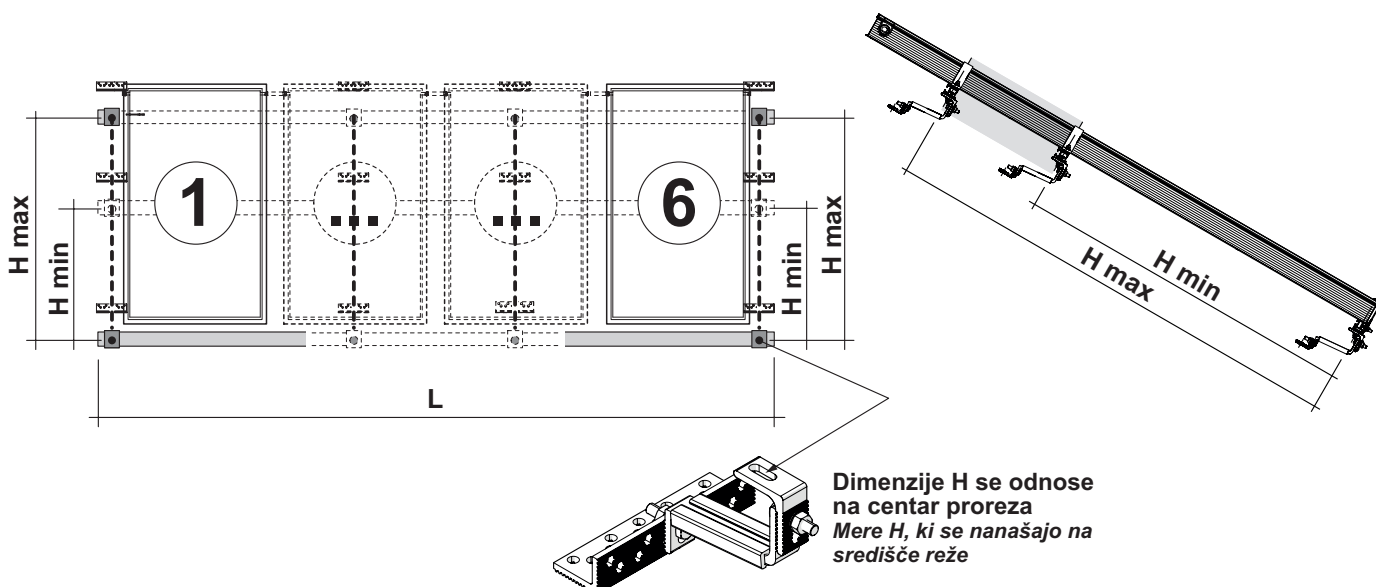

Dimenzije H se odnose na centar preseza  
Mere H, ki se nanašajo na središče reže

	Kvota Mera  H min - H max (cm)	Broj kolektora Število kolektorjev					
		1	2	3	4	5	6
		Dužina / Dolžina L (in cm)					
Kolektor 2,5 mq USPRAVNO sa PODLOGOM Kolektor 2,5 m <sup>2</sup> za NAVPIČNO MONTAŽO z OKVIRJEM	160 - 190	120	240	360	480	600	720
Kolektor 2,0 mq USPRAVNO sa PODLOGOM Kolektor 2,0 m <sup>2</sup> za NAVPIČNO MONTAŽO z OKVIRJEM	145 - 170	110	220	330	440	550	660
Kolektor 2,5 mq VODORAVNO sa PODLOGOM Kolektor 2,5 m <sup>2</sup> za VODORAVNO MONTAŽO z OKVIRJEM	90 - 110	210	420	630	840	1050	1260

## Sistem za fiksiranje na krov (D) Sistem za pritrnitev na streho (D)

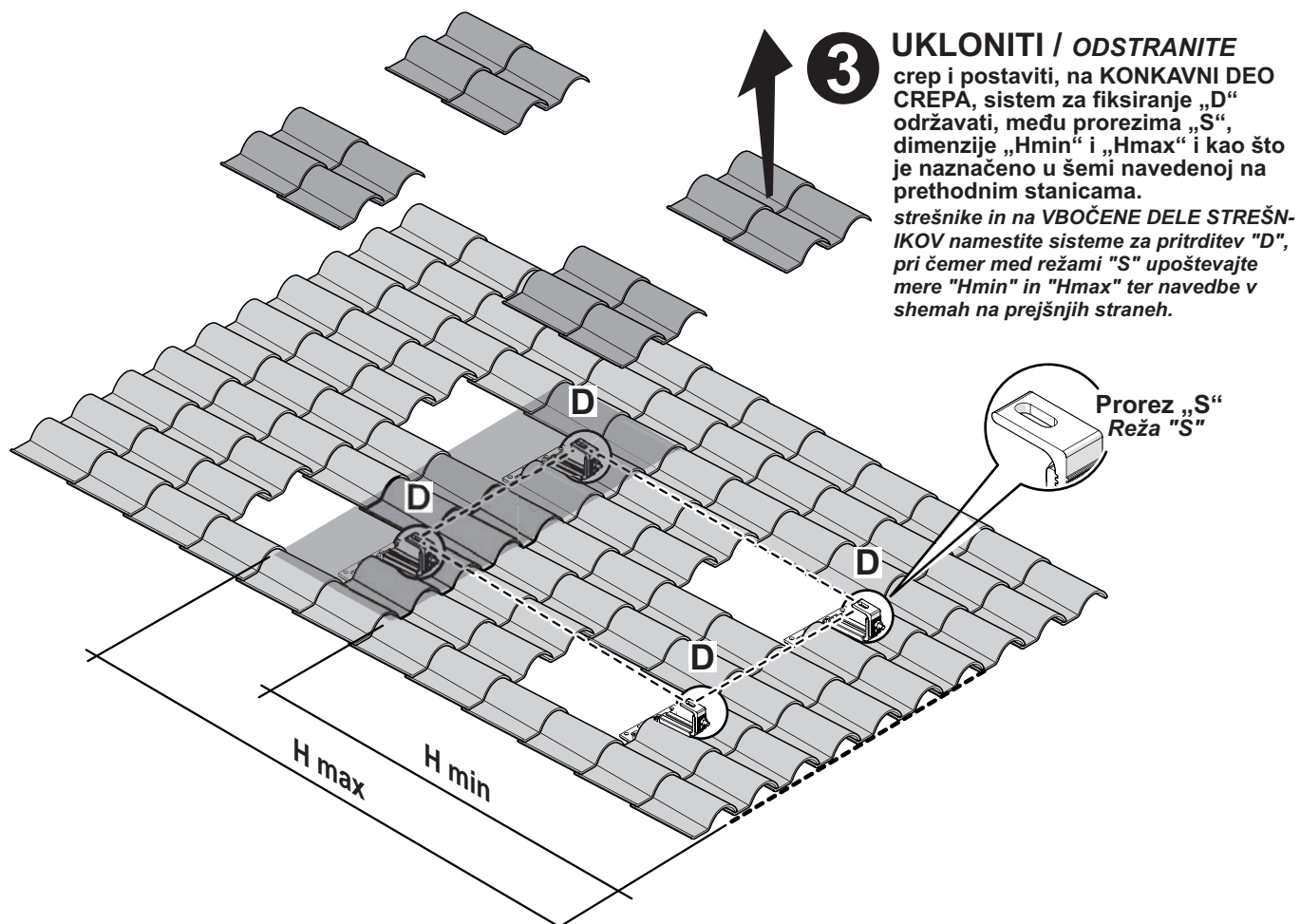
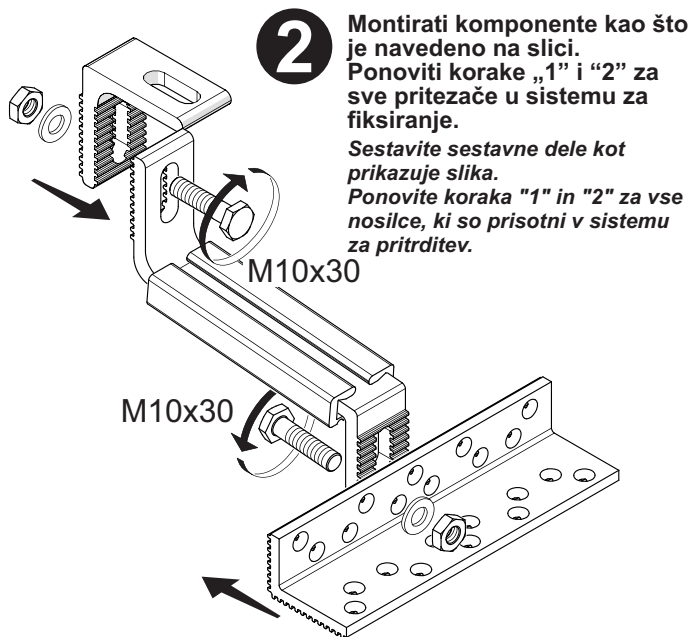
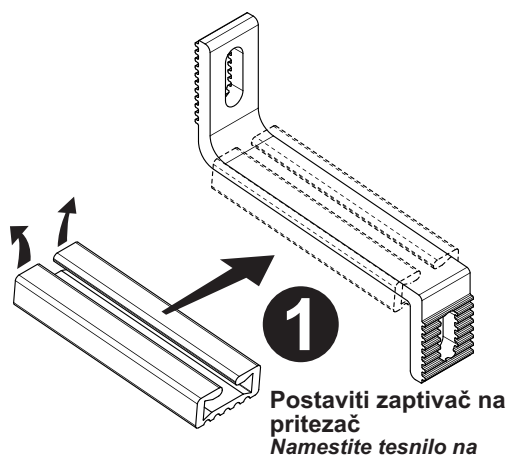

Prorez „S”  
Reža „S”

Izračunati poziciju sistema fiksiranja na takav način da pritezač na L ide na držače crepa

Izračunajte položaj sistema za pritrđitev, da bodo nosilci v obliki črke L varno položeni na strešnike

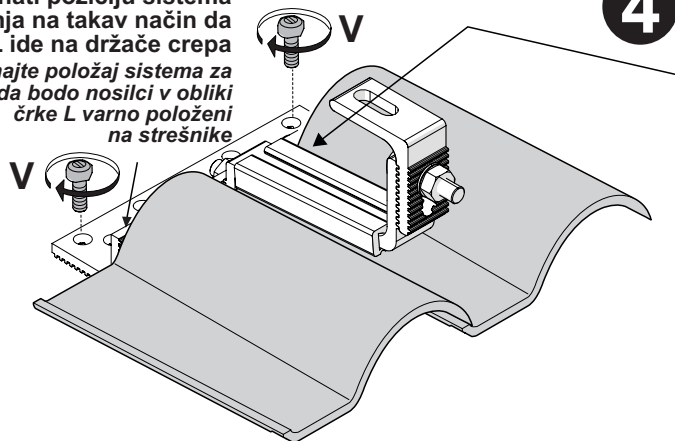

**4**

Prislonite u potpunosti sistem za fiksiranje na krov. Ako je neophodno, blago oblikujte crep.

Pričvrstite za krov pritezače (svaki pritezač mora da se pričvrsti na najmanje dve tačke i mora da se proveri čvrstina).

Šrafovi na „V“ NISU ISPORUČENI i treba da se obezbede u fazi instalacije u zavisnosti od karakteristika krova.

Sistem za pritrđitev se mora dobro prilagati strehi. Po potrebi rahlo preoblikujte strešnike.

Pritrdite nosilce na streho (vsak nosilec pritrđite na vsaj dveh točkah ter preverite tesnjenje).

Vijaki "V" NISO PRILOŽENI in jih je treba izbrati za namestitvev glede na značilnosti strehe.



CREP SE NE BUŠI U POTPUNOSTI.

NIKOLI NE LUKNJAJTE STREŠNIKOV.

**5**

## PONOVNO POSTAVLJANJE

PONOVNO POLOŽITE crep prethodno uklonjen predhodno odstranjene strešnike

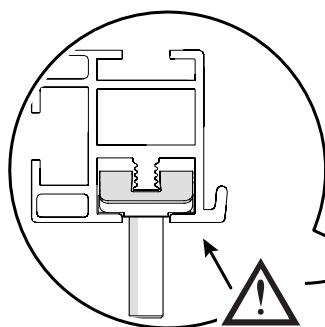
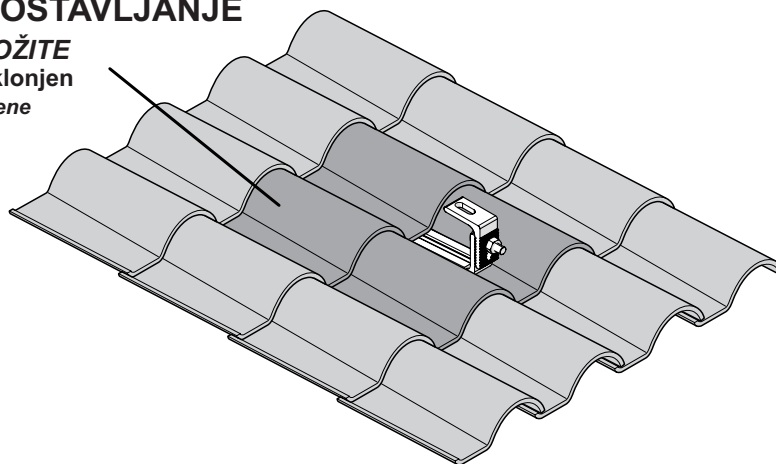

**6**

Postaviti i propustiti šrafove sa glavom čekića i odgovarajuća klanfa će blokirati rotaciju u gornjim potpornim polugama. Vstavite in pomaknite vijake s kladivasto glavom in ustrezno sponko za blokiranje vrtenja v zgornje nosilne letve.

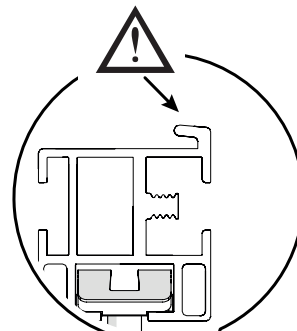

**6**

Postaviti i propustiti šrafove sa glavom čekića i odgovarajuća klanfa će blokirati rotaciju u donjim potpornim polugama. Vstavite in pomaknite vijake s kladivasto glavom in ustrezno sponko za blokiranje vrtenja v spodnje nosilne letve.

**7**

Visoko  
Zgornji del

Nisko  
Spodnji del

**7**

## **Spojnice (ubačene u opremu F), ako ih ima**

(Odvojeno se isporučuju)

## **Priključni spoji (priloženi kompletu F), če so prisotni**

(na voljo ločeno)

Ako postoji više potpornih poluga, poravnati ih koristeći spojnice (F) i potom ih blokirati odgovarajućim šrafova.

Če je treba namestiti več nosilnih letev, jih poravnajte s pomočjo priključnih spojev (F) in pritrdite z ustreznimi vijaki.

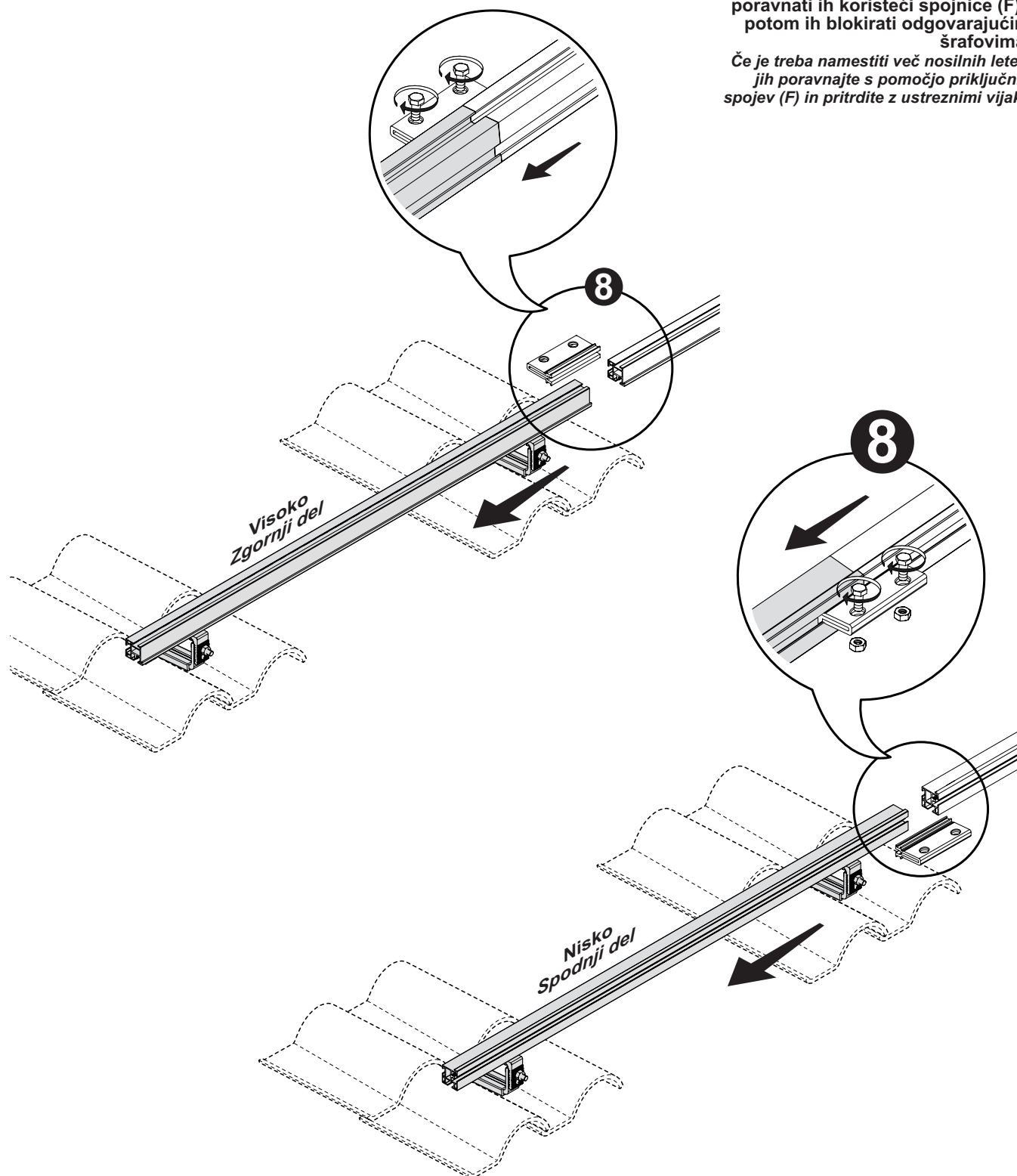

**Oprema za blokiranje kolektora (H)**  
**Komplet za blokiranje kolektorjev (H)**

**10a** Postaviti / Vstavite

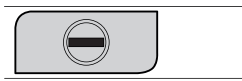

**10b** Rotirati za 90°  
Zasukajte za 90°

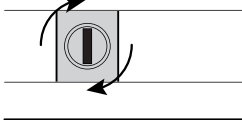

Nakon pričvršćivanja, proveriti da li je rez šrafa **POD PRAVIM UGLOM** u odnosu na položaj poluge. Po zategovanju proverite, da je zareza vijakā v **PRAVOKOTNEM POLOŽAJU** glede na postavitev letve.

Postaviti šrafove sa četvrtastom glavom i fiksirati solarni kolektor na gornje potporne poluge koristeći klamfu. Namestite vijake s pravokotno glavo in pritrdite sončni kolektor na zgornje nosilne letve s pomočjo sponk.



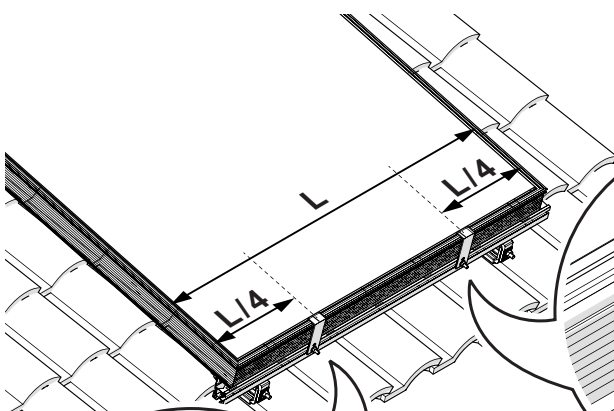

Zupci pritezača treba da se podudaraju sa zupcima rama kolektora. Poravnajte zobe sponke z zobmi okvirja kolektorja.

**9**

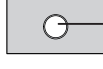

**11a**

-  Za kolektor od 2.0 m<sup>2</sup>
-  Za kolektorje velikosti 2,0 m<sup>2</sup>
-  Za kolektor od 2.5 m<sup>2</sup>
-  Za kolektorje velikosti 2,5 m<sup>2</sup>

**Pa** Postaviti / Vstavite

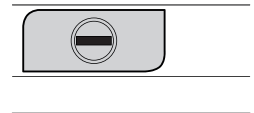

Postaviti šraf s pravougaonom glavom na položaj pa na donjoj potpornoj poluzi i postaviti pritezač na šraf. Namestite vijake s pravokotno glavo v položaj "Pa" v spodnji nosilni letvi in namestite sponke na vijake.



Nakon pričvršćivanja, proveriti da li je rez šrafa **POD PRAVIM UGLOM** u odnosu na položaj poluge. Po zategovanju proverite, da je zareza vijakā v **PRAVOKOTNEM POLOŽAJU** glede na postavitev letve.

**Pb** Rotirati za 90°  
Zasukajte za 90°

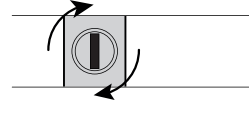

**11b**

Umetnuti pritezač na profil kolektora tako što ćete ga lagano okretati. Okrenuti šraf sa pravougaonom glavom na položaj Pb i pričvrstiti maticu na šraf. *Rahlo zasukajte sponko in jo vstavite na profil kolektorja. Zasukajte vijak s pravokotno glavo v položaj "Pb" in nanj pritrdite matico.*



Nakon fiksiranja kolektora, pritezač se ne sme oslanjati na staklo kolektora. Normalno je da postoji rastojanje od nekoliko mm između pritezača i stakla kolektora.

Po pritrditvi kolektorja sponka ne sme pritiskati na staklo kolektorja. Običajno je med sponko in steklom kolektorja razmak nekaj mm.

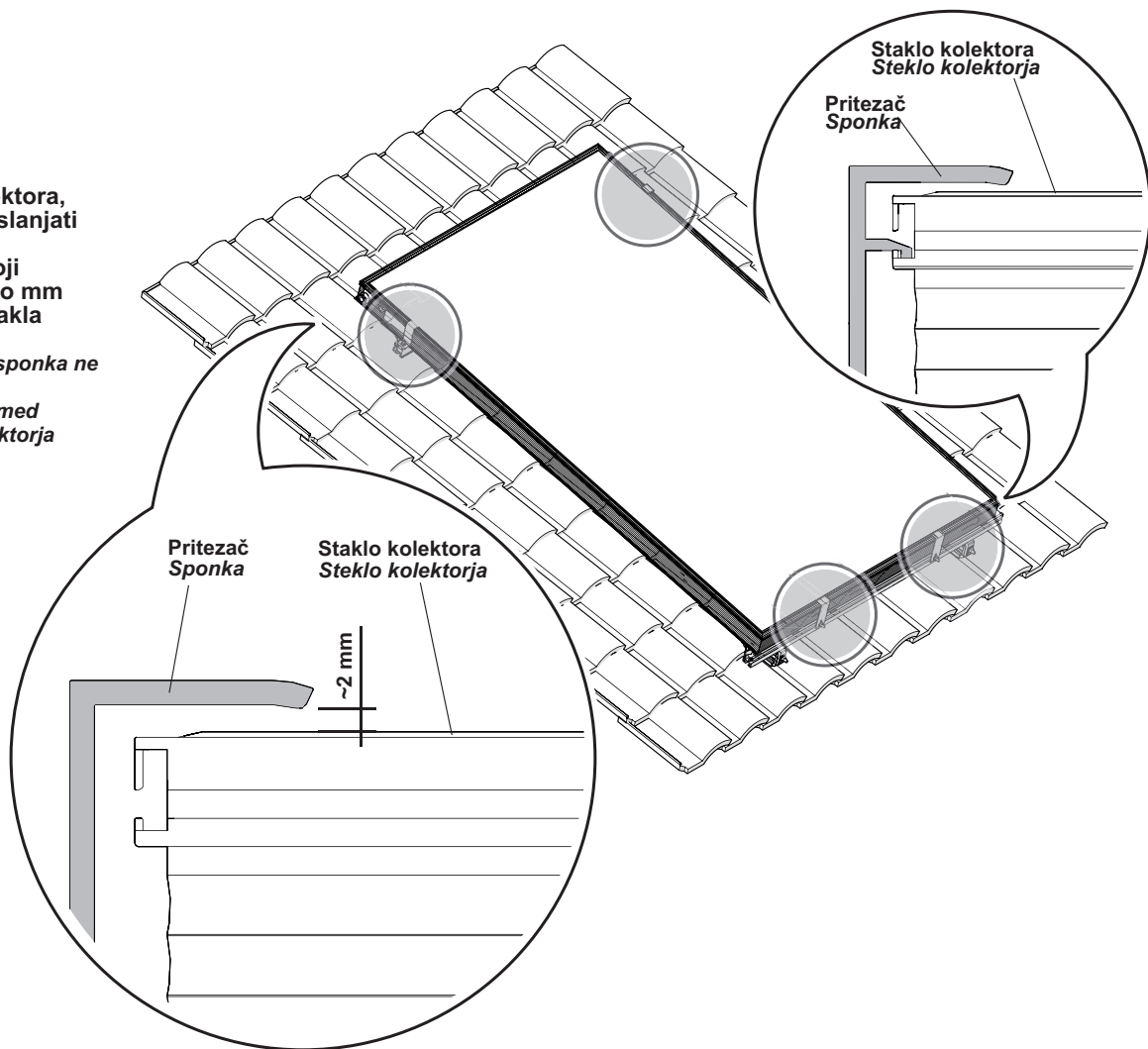

U slučaju da ima više kolektora, ponoviti tačke 9-11 za svaki kolektor.

V primeru većega števila kolektorjev ponovite opisani postopek od točke 9 do -11 za vsak posamezni kolektor.

**12**

Povezati međusobno kolektore zavrćući hidraulične spojeve odgovarajućim parom.

Kolektorje povežite med seboj z zategovanjem hidrauličnih priključkov s primernim zateznim momentom.

**KORISTITI SISTEM KLJUČ-KONTRAKLJUČ** da se ne bi oštetilo upijač.

**UPORABITE SISTEM KLJUČA IN PROTIKLJUČA**, da ne poškodujete blažilca.

